

# MARSTAIR

REFRIGERATION AND SPECIALIST AIR CONDITIONING

## A2LCELLARMATCH TECHNICAL MANUAL

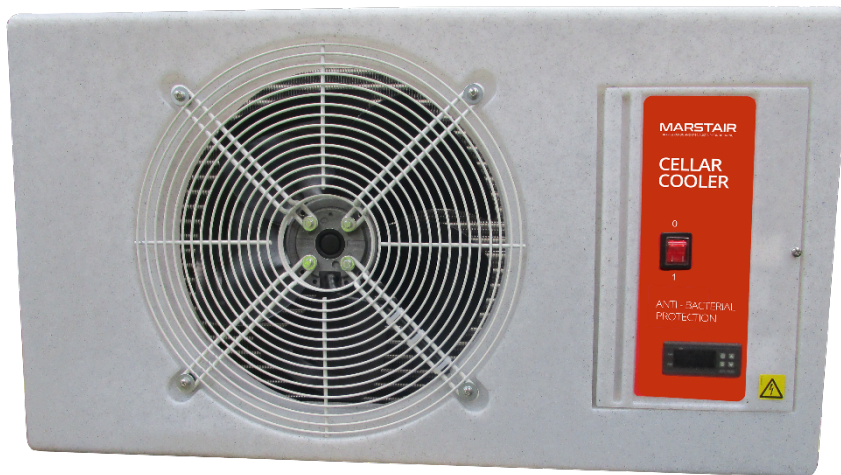

## CONTENTS

Section			Page
1	<b>General Information</b>	1A General Information	3
		1B General Installation procedure	4
2	<b>SMC Condensing Units</b>	2A Specification	5
		2B Performance Data.	6
		2C Mounting, Dimensions & Weights	6
		2D Pipework Installation.	8
		2E Pressure Testing	9
		2F Evacuating	9
		2G Electrical & Fuses	9
		2H Refrigerant	10
		2G Condensing Unit Wiring Diagrams	12
		2H Electronic Valve Driver Interface	13
		2I Electronic Valve Driver Parameters	15
		2J Eco Design Information Tables	20
		2K Component Identification SMC+	22
		2L Condensing Unit Maintenance	23
3	<b>Evaporators</b>	3A Component Identification	24
		3B Unit Dimensions	25
		3C Specification	26
		3D Evaporator Installation	27
		3E Evaporator Operation	28
		3F Maintenance	29
		3G Alarm Installation	30
		3H Evaporator Wiring Diagram	31
		3I Refrigerant System Schematic Diagram	31
4	<b>System selection process</b>		32
5	<b>Spares</b>		32
6	<b>End of life requirements</b>		32
7	<b>Installation risk assessment</b>		33

## 1 – GENERAL INFORMATION

### 1A GENERAL INFORMATION

Installation must be carried out in accordance with the Marstair installation manual, EN 378 and national codes and guidance.

1. Installation work on this equipment to be completed by F Gas certified Technicians who are fully conversant with the appropriate Refrigeration and Electrical practices and have sound knowledge of current Industrial Safe Working practices. It is also advisable that technicians hold the ACRIB Understanding the properties of flammable refrigerants (A2L, A2 and A3) qualification.

NOTE: it is the responsibility of the operator to ensure the technician is certified to the correct standard (EN13313 or equivalent).

2. These units are supplied with a holding charge of oxygen free nitrogen and polyolester oil. Do not mix oils or refrigerants.
3. These units when installed contain live electrical components, moving parts and refrigerant under pressure. Always site out of reach of children and protect from vandalism.
4. The data plate only gives information for the individual indoor or outdoor unit. For system details add input power and current of indoor and outdoor unit, including any heater load.
5. The refrigerant used should be identified by locating a refrigerant label on the unit case
6. A suitable risk assessment of the installation must be carried out. This ensures a safe working environment is maintained in accordance with The Dangerous Substances and Explosive Atmosphere Regulations and the Management of Health and Safety at Work Regulations. A step by step guidance template is provided within these instructions.
7. The condensing unit must be installed outside.
8. Systems uses R454C refrigerant which is classed as an A2L flammable gas



## 1B GENERAL INSTALLATION PROCEDURE

- Carry out “step by step” or full risk assessment
- Ensure that no sources of ignition are present during installation
- Only certified natural persons should be present during the installation
- Correct selection of tools and equipment compatible with A2L refrigerants. This should include the following:
  - Flammable gas leak detector placed at a low level next to the service valves of the condensing unit.
  - If adequate natural ventilation is not present throughout the installation process, then forced ventilation should be employed via an A2L compatible or ATEX rated fan and motor.
  - When pressure testing through a refrigerant manifold, ensure that it is suitable for the pressure (no sight glass fitted).
  - A2L compatible 2 stage vacuum pump, exhausted to a safe well ventilated area and away from any source of ignition (check exhaust fumes with flammable gas leak detector).
  - R454C bottle adaptor (left handed female and right handed male connections DIN477-1 21.8mm LH, External, 14 T.P.I).
  - All refrigerant hoses should be as short as possible and have self-closing or ball valve connections in accordance with BS EN 378.
  - If additional refrigerant is to be added, charge in liquid state and ensure a flammable gas leak detector is positioned at a low level near the connections. (If the flammable gas leak detector indicates the presence of a flammable atmosphere, do not energise or de-energise any electrical components until a safe environment has been ensured.)
- Leak checking the system in accordance with EN 1516/2017 directly after installation.
- If a leak is discovered, energise the flammable gas leak detector and place at a low level near connections to the recovery machine and cylinder. Connect an A2L compatible recovery machine and recover into a suitable recovery cylinder (red painted cylinder valve guard and shoulder) in accordance with BS EN 378.

## 2 - SMC CONDENSING UNITS

### 2A SPECIFICATION.

SME		20	30	45	50	80
Nominal cooling capacity (-10°C evaporating temp & 32°C ambient temp) R454C	kW	1.53	1.78	2.96	4.17	5.26
1 Ph (230V 50Hz) compressor load only (at nominal cooling capacity)						
Power (nominal)	kW	0.83	0.98	N/A	N/A	N/A
Starting current LRA	A	33	42.2	N/A	N/A	N/A
Nominal current FLA	A	5.8	6.4	N/A	N/A	N/A
3Ph (400v 50Hz) compressor load only (at nominal cooling capacity)						
Power (nominal)	kW	N/A	N/A	1.36	1.75	2.18
Starting current LRA	A	N/A	N/A	26	32	46
Nominal current FLA	A	N/A	N/A	4.2	5.5	6.8
Sound Pressure Levels (SPL) at 10m distance in free field conditions @ 27°C external ambient.						
dBA		34	34	33	33	34
NR		28	28	27	27	27
Condenser fan (1Ph 230V 50Hz)						
Airflow (max speed)	m <sup>3</sup> /s	0.323	0.713	0.713	0.713	0.713
Airflow motor rating	kW	0.065	0.13	0.13	0.13	0.13
Nominal current FLA	A	0.4	0.6	0.6	0.6	0.6
Fans: No. x diameter	#x	1x350	1x457	1x457	1x457	1x457
	mm					
Fans max speed	r.p.m	940	940	940	940	940

**2B PERFORMANCE DATA.**

MODEL	Ambient temperature	Evaporating temperature				
		-20	-15	-10	-5	0
SMC 20	27	0.95	1.25	1.69	2.02	2.59
	30	0.90	1.18	1.60	1.91	2.44
	32	0.86	1.13	1.54	1.84	2.35
	35	0.81	1.07	1.45	1.73	2.22
	38	0.77	1.01	1.37	1.63	2.09
	40	0.74	0.97	1.31	1.57	2.01
SMC 30	27	1.10	1.44	1.96	2.34	3.00
	30	1.04	1.36	1.85	2.21	2.83
	32	1.00	1.31	1.78	2.13	2.72
	35	0.94	1.24	1.68	2.00	2.57
	38	0.89	1.16	1.58	1.89	2.42
	40	0.85	1.12	1.52	1.81	2.32
SMC 45	27	2.03	2.55	3.16	3.88	4.72
	30	1.95	2.45	3.04	3.74	4.55
	32	1.90	2.38	2.96	3.64	4.44
	35	1.81	2.28	2.84	3.50	4.26
	38	1.72	2.18	2.71	3.35	4.09
	40	1.67	2.11	2.63	3.25	3.97
SMC 50	27	2.86	3.60	4.46	5.47	6.66
	30	2.75	3.46	4.29	5.28	6.42
	32	2.68	3.36	4.18	5.13	6.26
	35	2.55	3.22	4.01	4.94	6.01
	38	2.43	3.08	3.82	4.73	5.77
	40	2.36	2.98	3.71	4.58	5.60
SMC 80	27	3.61	4.53	5.62	6.90	8.39
	30	3.47	4.36	5.41	6.65	8.09
	32	3.38	4.23	5.26	6.47	7.90
	35	3.22	4.05	5.05	6.22	7.58
	38	3.06	3.88	4.82	5.96	7.27
	40	2.97	3.75	4.68	5.78	7.06

**2C MOUNTING, DIMENSIONS & WEIGHTS.**

These units are designed to stand on a flat surface. If the unit is to be wall mounted the following kits are available.

KIT	SMC 15-80
Mounting Bracket	55021100

Whether floor or wall mounted, it is essential that the mounting surface is capable of supporting the unit weight. Leave space around the unit for air circulation and access for installation and maintenance.

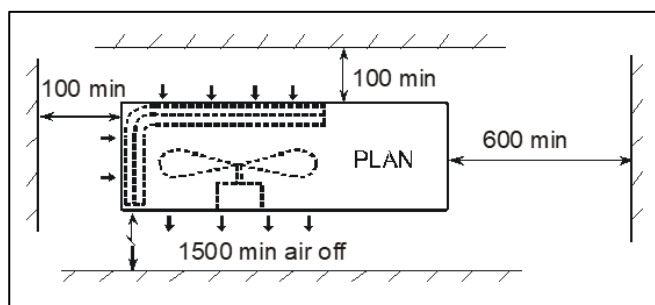

Dimensions in mm.

Condensing unit to be installed outside and not in an enclosed area.

Smoking and naked flames should be prohibited around the area around the condensing unit.

Packed weights					
Model	Dimensions			Weight	
	Width	Depth	Height	1ph	3ph
20	1060	340	620	49	
30	1060	340	620	50	
45	1160	390	720		63
50	1160	390	720		66
80	1160	390	720		68

SMC 20-80 (Dimensions in mm.)

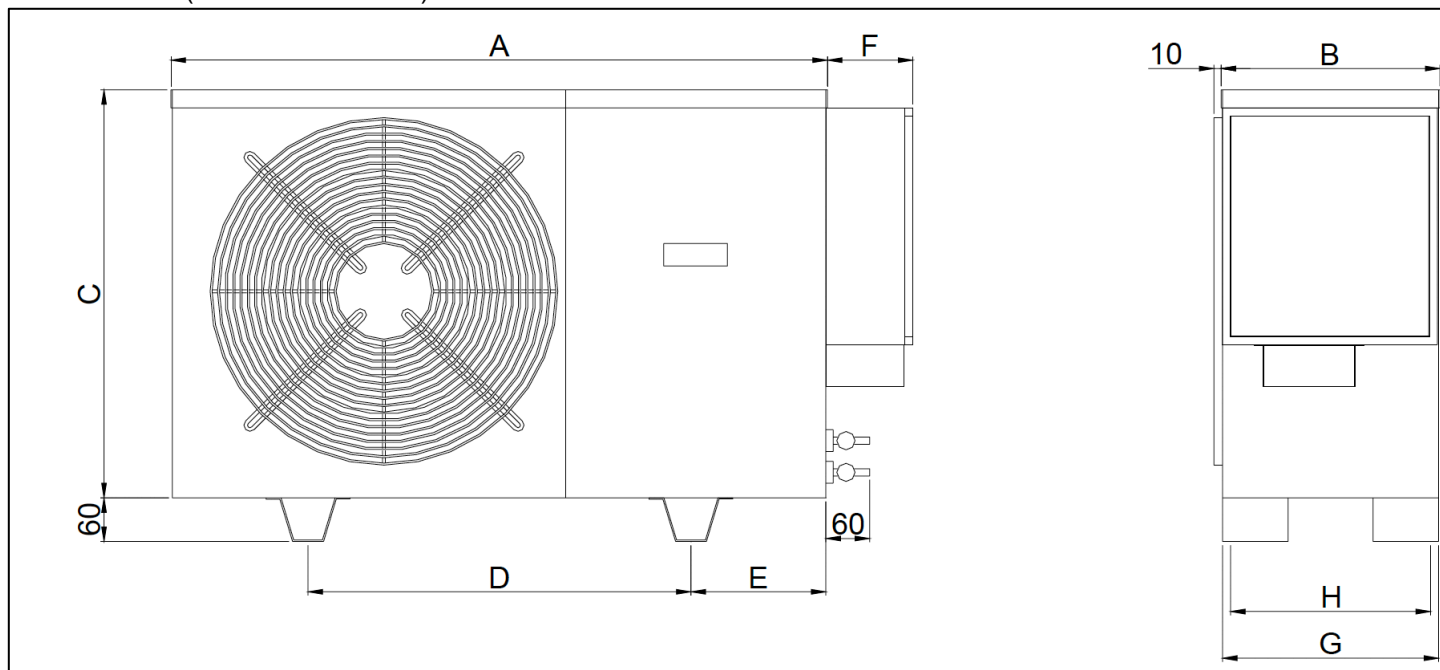

Model	Dimensions								Weight	
	A	B	C	D	E	F	G	H	1ph	3ph
20	900	300	560	525	185	117	296	274	47	
30	900	300	560	525	185	117	296	274	48	
50	1000	350	660	495	250	117	346	324		64
80	1000	350	660	495	250	117	346	324		66

## 2D PIPEWORK INSTALLATION.

Supplied Sweat connections					
Model SMC					
Size	20	30	45	50	80
Expansion	3/8	3/8	3/8	1/2	1/2
Suction	1/2	1/2	1/2	1/2	5/8

The installation section of the risk assessment template or equivalent should be carried out before commencing installation.

When installing a split refrigeration system, all interconnecting refrigeration pipework must be manufactured, jointed, tested, insulated and installed in such a way as to ensure that damage cannot occur during normal, service and maintenance operations that may cause a rupture and subsequent leakage.

It is advisable, wherever possible, that brazed or permanent mechanical joints are used when jointing refrigeration pipework designed for an A2L refrigerant.

### MAXIMUM PIPE RUNS

80m maximum including 20m lift (50m SMC 15-20). There will be no significant loss of capacity for extended pipe runs provided pipes are correctly sized.

### CALCULATING EQUIVALENT LENGTHS

The effects of bends and fittings must be taken into account.

Pipe sizes are based on:

Minimum of 2.5 m/s (500 fpm) suction gas velocity for horizontal or downflow.

Minimum of 5.0 m/s (1000 fpm) suction gas velocity for upflow.

Maximum of 20.0 m/s (4000 fpm) suction gas.

Where vertical risers exceed 3m, oil traps must be formed in the pipe. This will help ensure that oil returns to the compressor. Typically fit an oil trap every 3m with a trap at the bottom of the riser.

### GOOD PRACTICE

- Keep pipe runs as short as possible.
- Avoid sharp bends
- Fully insulate both suction and expansion lines including mechanical connections
- Try to avoid running pipes through hot areas.

SMC	Suction pipe size						Expansion pipe size				
	3/8"	1/2"	5/8"	3/4"	7/8"	1-1/8"	1/4"	3/8"	1/2"	5/8"	3/4"
20	7.5	23	50					50			
30		15	50	80				50	80		
45		10	36	80				7.5	80		
50		7.5	18	50	80			7.5	50	80	
80			11	30	80				50	80	

### 1. Connecting the pipework:

- a. Release the nitrogen holding charge by slowly opening the valves using a 5mm or 8mm allen key.
- b. Ensure the suction line is fully insulated.
- c. Connect the pipework between the units. Do not leave pipes ends, valves etc open to the atmosphere.
- d. Use a protective shield to avoid scorching the side panel.

## 2E PRESSURE TESTING

The pressure testing section of the risk assessment template or equivalent should be carried out before commencing pressure testing.

Pressure and leak testing of the system should be completed in accordance with EN 378.

Note: The interconnecting pipework and evaporator are all on the low-pressure side of the system. The only high-pressure side of the system is within the condensing unit. Therefore, the pressure and leak testing of the pipework can be treated as such within EN 378.

The matched MBMT evaporators all have a maximum allowable pressure of 25Barg

The condensing unit is fitted with a high-pressure limiting device

SMC20-30 = 23Bar

SMC45-80 = 26Bar

The condensing unit has a pressure relief valve is set to 29.5Bar which is equal to the condensing unit maximum allowable pressure do not exceed this pressure if testing the condensing unit.

## 2F EVACUATING

The Evacuation section of the risk assessment template or equivalent should be carried out before commencing Evacuation.

With the valves open, connect a vacuum pump to the service ports on the outdoor unit valves. Evacuate the interconnecting pipework and indoor unit to 1000 microns (1 Torr) or better. Allow this to be held for a minimum of 15 minutes.

## 2G ELECTRICAL & FUSES

The installer supplies mains, control and interconnecting cables: equipment must be earthed.

Wiring must be carried out in accordance with local and national codes.

Mains supply cables must be size compatible with the recommended fuse.

Cable clamps for use with stranded cables are supplied in units 15 - 100 and should be used to secure incoming/outgoing cables. Installers must supply a method of securing solid sheathed cables.

### THREE PHASE UNITS WITH SCROLL COMPRESSORS:

On 3 Ph units sizes it is possible for the scroll compressor to run backwards.

This becomes obvious on start up - the compressor will not develop a normal running pressure differential and the top will not become warm: it may be excessively noisy. If this happens, switch off the mains power and exchange the two supply phases **not** connected to the indoor unit. This will correct the rotation.

**FUSES:** The system and its supply/interconnecting wiring must be protected by fuses, preferably High Rupture Current (HRC) motor rated types (to BS EN60269) or miniature circuit breakers to (BS EN60898) or local codes having similar time lag characteristics, that allow starting of the compressor yet still afford close overcurrent protection under running conditions. The ratings below are for HRC motor rated fuses.

1PH Fuse		
SMC	20	30
Fuse	16	16

3PH Fuse			
SMC	45	50	80
Fuse	10	10	10

The ratings are for the outdoor unit only. Currents for the indoor units including heaters if applicable should be noted and the fuse size increased pro-rata if using same supply.

## 2H REFRIGERANT

### Charging the system

The charging of refrigerant section of the risk assessment template or equivalent should be carried out before commencing refrigerant charging.

1. Evacuate the system and interconnecting pipework ensuring the service valves are fully open.
2. Allow the evacuated system to draw in the majority of the refrigerant charge.
3. The final charge should be adjusted with the system running.
4. All units are fitted with head pressure control. The link wire across the orange terminals allows the fan to operate at full speed. **THIS SHOULD BE REMOVED AFTER CHARGING**
5. A random start delay of up to 1 minute occurs when mains is first applied. A 3 minute delay occurs between successive compressor operations on all systems.
6. Refrigerant and polyolester oil should be introduced through the Schrader valve the service port on the suction service valve on the outdoor unit. **Ensure the refrigerant is the correct type, as shown on the rating plate.** R454C must always be added in the liquid state.
7. Run the system for a few minutes to allow it to stabilize. Check suction and head pressures.
8. **Systems should not be overcharged, to avoid liquid return to the compressor**

#### 9. HEAD PRESSURE CONTROL ALCO (FSY-42S) & SAGINOMIYA (XGE-4C)

The head pressure controller is factory set to suit the refrigerant. It may be necessary to adjust this to suit site conditions, to raise or lower the nominal head pressure.

##### ALCO (FSY-42S)

- a. With the system switched off, connect a high pressure gauge to the liquid line service valve.
- b. Switch on the system and run for a few minutes to stabilise.
- c. The head pressure should be approximately:  
**R454C: 210-220 psig (14.0-15.2barg)** to achieve this remove sealing plug and insert 2mm or 5/64" allen key into setting screw. Turn allen key clockwise (+) or counter clockwise (-) to readjust the setting.

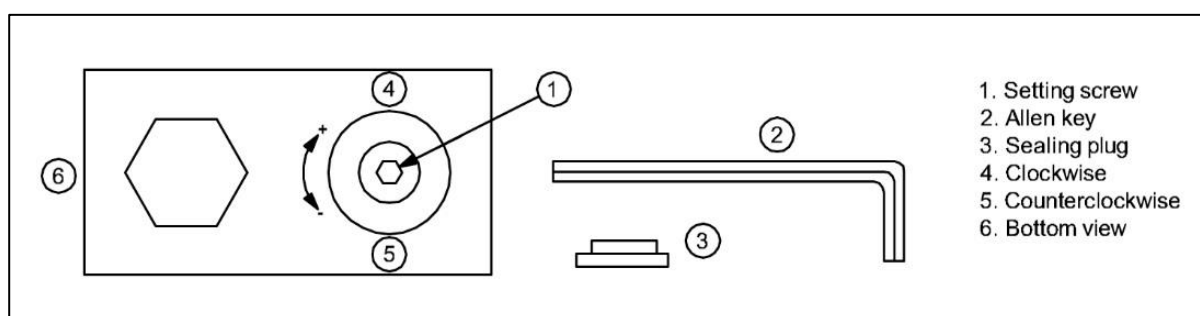

**NOTE:** The condenser fan may stop if the operating pressure drops below 200 psig (13.8 barg)  
Do not turn setting screw **more than 3 turns clockwise (+3)**.

##### Pressure changes per turn of adjusting screw:

Pressure change: 9.2 ... 21.2 bar:

Clockwise ~ +2,5 bar, counter clockwise ~ -2,5 bar

After adjustment, re-insert sealing plug and make sure that it is properly fitted. IP65 protection requires firmly sealed plug

##### NOTES:

Tolerances for condensing temperatures setpoint:  $\pm 2K$

## SAGINOMIYA (XGE-4C)

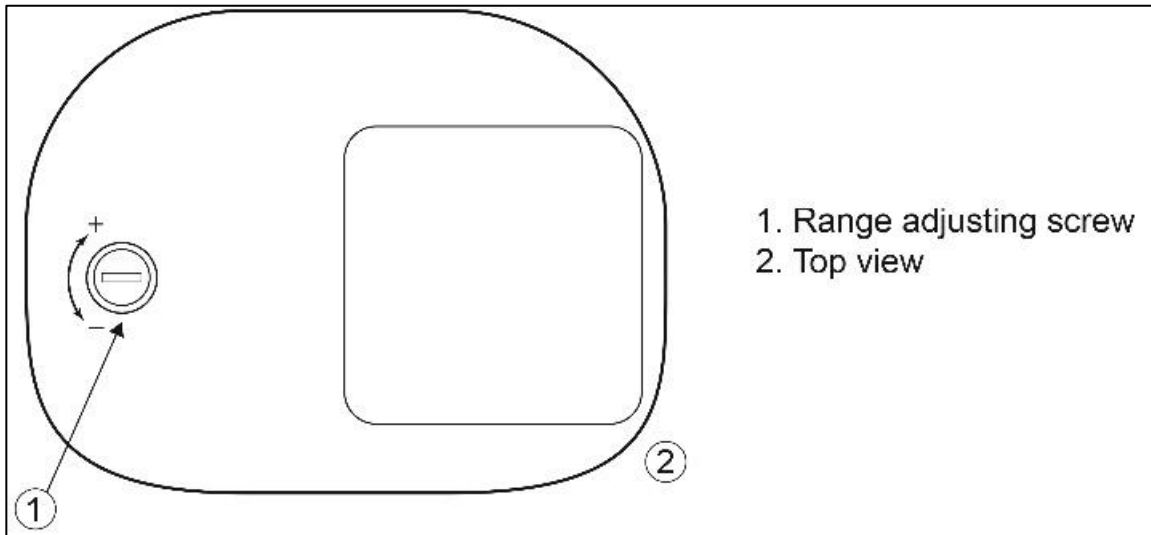

**R454C: 210-220 psig (14.0-15.2 barg)** to achieve this turn the range adjusting screw clockwise (+) for increasing the setting value or counter clockwise (-) for decreasing the setting value.

**Pressure changes per 1 turn of adjusting screw:**

Pressure change: 10 ... 25bar:

Clockwise ~ +1.5 bar, counter clockwise ~ -1.5 ba

# 2G CONDENSING UNIT WIRING DIAGRAMS

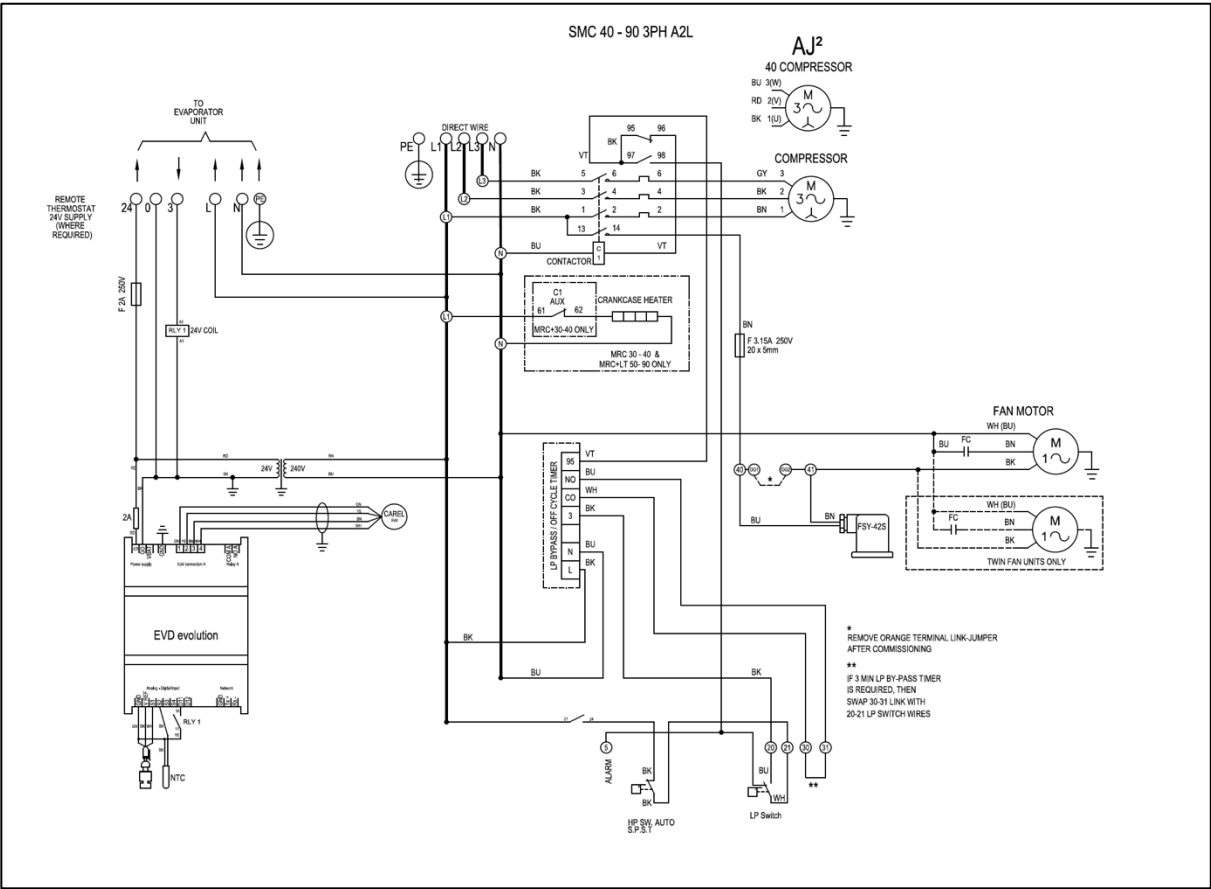
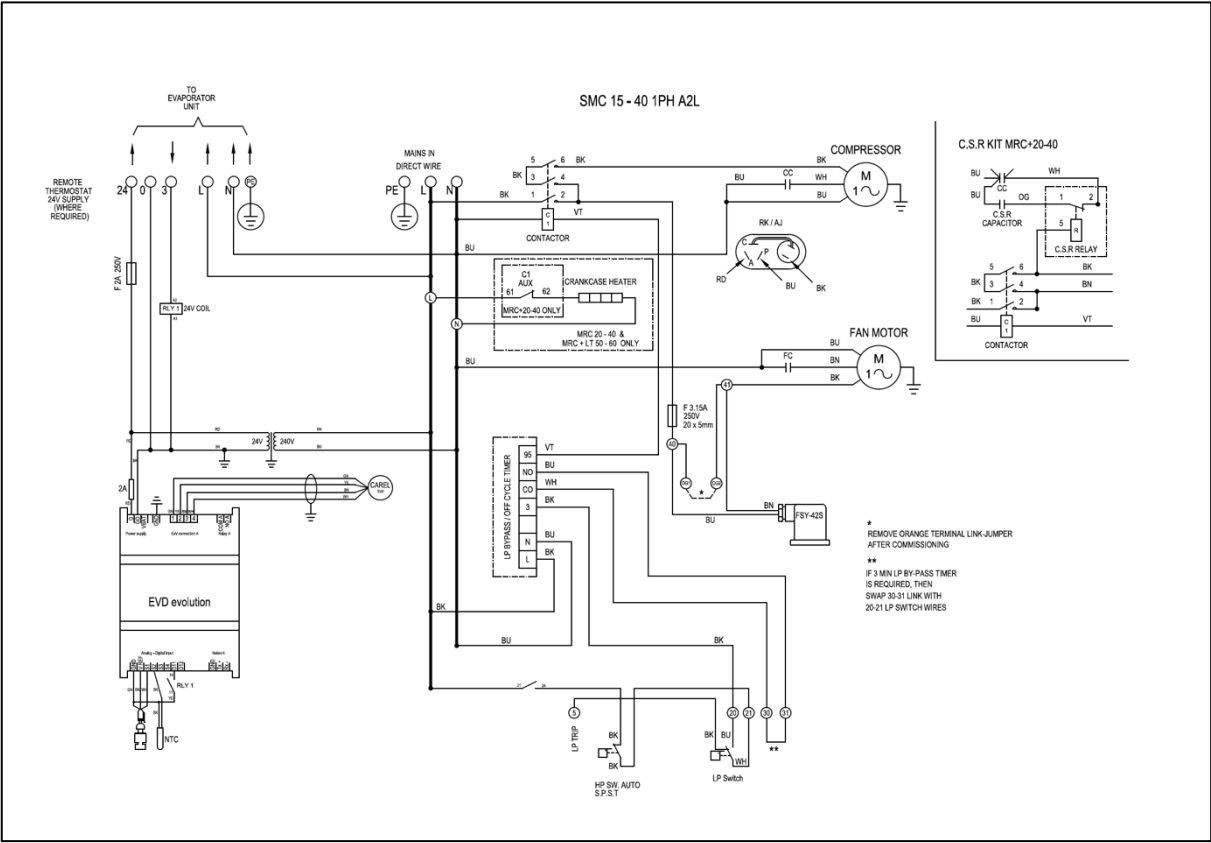

## 2H ELECTRONIC VALVE DRIVER INTERFACE

Note: The Electronic valve will be factory set to run at 6°C

The user interface consists of 5 LEDs that display the operating status, as shown in the table:

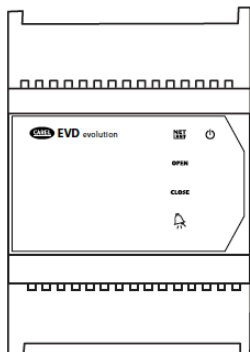

Fig. 2H.a

Key:	ON	OFF	Flashing
NET	Connection available	No connection	Communication error
OPEN	Opening valve	-	Driver disabled (*)
CLOSE	Closing valve	-	Driver disabled (*)
	Active alarm	-	-
	Driver powered	Driver not powered	Wrong power supply (see chap. Alarms)

Tab. 2H.a

(\*) Awaiting completion of the initial configuration

### 2H.1 Assembling the display board (accessory)

The display board, once installed, is used to perform all the configuration and programming operations on the driver. It displays the operating status, the significant values for the type of control that the driver is performing (e.g. superheat control), the alarms, the status of the digital inputs and the relay output. Finally, it can save the configuration parameters for one driver and transfer them to a second driver (see the procedure for upload and download parameters).

For installation:

- remove the cover, pressing on the fastening points;
- fit the display board, as shown;
- the display will come on, and if the driver is being commissioned, the guided configuration procedure will start.

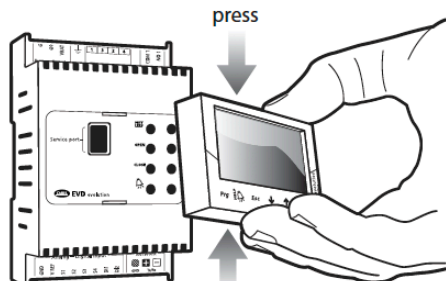

Fig. 2H.b

**Important:** the driver is not activated if the configuration procedure has not been completed.

The front panel now holds the display and the keypad, made up of 6 buttons that, pressed alone or in combination, are used to perform all the configuration and programming operations on the driver.

### 2H.2 Display and keypad

The graphic display shows 2 system variables, the control status of the driver, the activation of the protectors, any alarms and the status of the relay output.

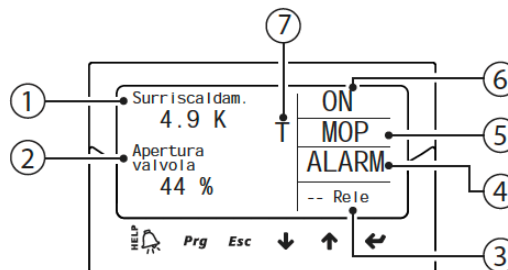

Fig. 2H.c

Key:	Function
1	1st variable displayed
2	2nd variable displayed
3	relay status
4	alarm (press "HELP")
5	protector activated
6	control status
7	adaptive control in progress

#### Display writings

	Control status		Protection active
ON	Operation	LowSH	Low superheat
OFF	Standby	LOP	Low evaporation temperature
POS	Positioning	MOP	High evaporation temperature
WAIT	Wait	HiTcond	High condensing temperature
CLOSE	Closing		
INIT	Valve motor error recognition procedure (*)		
TUN	Tuning in progress		

Tab. 2H.b

#### Keypad

Button	Function
Prg	opens the screen for entering the password to access programming mode.
HELP	<ul style="list-style-type: none"> <li>• if in alarm status, displays the alarm queue;</li> <li>• in the "Manufacturer" level, when scrolling the parameters, shows the explanation screens (Help).</li> </ul>
Esc	<ul style="list-style-type: none"> <li>• exits the Programming (Service/Manufacturer) and Display modes;</li> <li>• after setting a parameter, exits without saving the changes.</li> </ul>
↓ / ↑	<ul style="list-style-type: none"> <li>• navigates the display screens;</li> <li>• increases/decreases the value.</li> </ul>
UP / DOWN	
	<ul style="list-style-type: none"> <li>• switches from the display to parameter programming mode;</li> <li>• confirms the value and returns to the list of parameters.</li> </ul>
Enter	

Tab. 2H.c

**Note:** the variables displayed as standard can be selected by configuring the parameters "Display main var. 1" and "Display main var. 2" accordingly. See the list of parameters.

### 2H.3 Display mode (display)

Display mode is used to display the useful variables showing the operation of the system.

The variables displayed depend on the type of control selected.

1. press Esc one or more times to switch to the standard display;
2. press UP/DOWN: the display shows a graph of the superheat, the percentage of valve opening, the evaporation pressure and temperature and the suction temperature variables;
3. press UP/DOWN: the variables are shown on the display, followed by the screens with the probe and valve motor electrical connections;
4. press Esc to exit display mode.

For the complete list of the variables shown on the display, see the chapter: "Table of parameters".

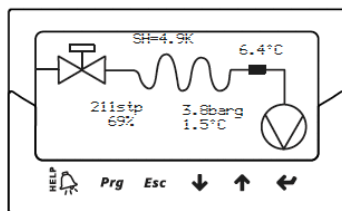

Fig. 2H.d

### 2H.4 Programming mode (display)

The parameters can be modified using the front keypad. Access differs according to the user level: Service (Installer) and manufacturer.

#### Modifying the Service parameters

The Service parameters, as well as the parameters for commissioning the driver, also include those for the configuration of the inputs, the relay output, the superheat set point or the type of control in general, and the protection thresholds. See the table of parameters.

Procedure:

1. press Esc one or more times to switch to the standard display;
2. press Prg: the display shows a screen with the PASSWORD request;
3. press ENTER and enter the **password for the Service level: 22**, starting from the right-most figure and confirming each figure with ENTER;
4. if the value entered is correct, the first modifiable parameter is displayed, network address;
5. press UP/DOWN to select the parameter to be set;
6. press ENTER to move to the value of the parameter;
7. press UP/DOWN to modify the value;
8. press ENTER to save the new value of the parameter;
9. repeat steps 5, 6, 7, 8 to modify the other parameters;
10. press Esc to exit the procedure for modifying the Service parameters.

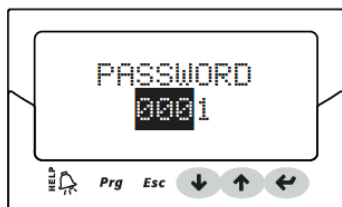

Fig. 2H.e

#### Note:

- if when setting a parameter the value entered is out-of-range, this is not accepted and the parameter soon after returns to the previous value;
- if no button is pressed, after 5 min the display automatically returns to the standard mode;
- to set a negative value move to the left-most digit and press Up/Down.

#### Modifying the Manufacturer parameters

The Manufacturer level is used to configure all the driver parameters, and consequently, in addition to the Service parameters, the parameters relating to alarm management, the probes and the configuration of the valve. See the table of parameters.

Procedure:

1. press Esc one or more times to switch to the standard display;
2. press Prg: the display shows a screen with the PASSWORD request;
3. press ENTER and enter the Manufacturer level password: 66, starting from the right-most figure and confirming each figure with ENTER;
4. if the value entered is correct, the list of parameter categories is shown:
  - Configuration
  - Probes
  - Control
  - Special
  - Alarm configuration
  - Valve
5. press the UP/DOWN buttons to select the category and ENTER to access the first parameter in the category;
6. press UP/DOWN to select the parameter to be set and ENTER to move to the value of the parameter;
7. press UP/DOWN to modify the value;
8. press ENTER to save the new value of the parameter;
9. repeat steps 6, 7, 8 to modify the other parameters;
10. press Esc to exit the procedure for modifying the Manufacturer parameters.

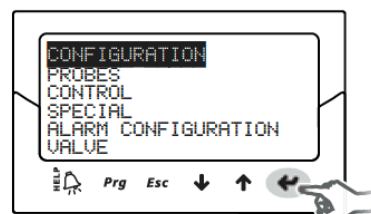

Fig. 2H.f

#### Note:

- all the driver parameters can be modified by entering the Manufacturer level;
- if when setting a parameter the value entered is out-of-range, this is not accepted and the parameter soon after returns to the previous value;
- if no button is pressed, after 5 min the display automatically returns to the standard mode.

## 2I ELECTRONIC VALVE DRIVER PARAMETERS

user*	Parameter/description	Def.	Min.	Max.	UOM	Type**	CAREL	Modbus®	Notes
<b>CONFIGURATION</b>									
A	Network address	pLAN: 30 others: 198	1	207	-	I	11	138	
A	Refrigerant: 0= user defined; 1=R22 2=R134a 3=R404A 4=R407C 5= R410A 6=R507A 7=R290 8=R600 9=R600a 10= R717 11=R744 12=R728 13=R1270 14= R417A 15=R422D 16= R413A 17= R422A 18=R423A 19= R407A 20=R427A 21= R245FA 22=R407F 23=R32 24=HTR01 25=HTR02 26=R23 27=R1234yf 28=R1234ze 29=R455A 30=R170 31=R442A 32=R447A 33=R448A 34=R449A 35=R450A 36= R452A 37= R508B 38=R452B 39=R513A 40=R454B	0 = User Defined	-	-	-	I	13	140	
A	Valve: 0= user defined 1=CAREL E <sup>X</sup> V 2= Alco EX4 3= Alco EX5 4= Alco EX6 5= Alco EX7 6=Alco EX8 330Hz recommend 7= Alco EX8 500Hz specific 8= Sporlan SEI 0.5-11 9= Sporlan SER 1.5-20 10= Sporlan SEI30 11= Sporlan SEI50 12= Sporlan SEH 100 13= Sporlan SEH 175 14= Danfoss ETS 12.5-25B 15= Danfoss ETS 50B 16= Danfoss ETS 100B 17= Danfoss ETS 250 18= Danfoss ETS 400 19= Two E <sup>X</sup> V CAREL connected together 20= Sporlan SER(I)G,J,K 21= Danfoss CCM 10-20-30 22= Danfoss CCM 40 23= Danfoss CCMT 2-4-8 24= Disabled	1 = CAREL E <sup>X</sup> V	-	-	-	I	14	141	
A	Probe S1: 0= user defined Ratiometric (OUT=0...5 V) 1=-1...4,2 barg 2=-0,4...9,3 barg 3=-1...9,3 barg 4=0...17,3 barg 5=0,85...34,2 barg 6=0...34,5 barg 7=0...45 barg 8= -0,5...7 barg 9= 0...10 barg 10= 0...18,2 barg 11=0...25 barg 12=0...30 barg 13= 0...44,8 barg 14=remoto, -0,5...7 barg 15=remoto, 0...10 barg 16=remoto, 0...18,2 barg 17=remoto, 0...25 barg 18=remoto, 0...30 barg 19=remoto, 0...44,8 barg 20= Segnale esterno 4...20 mA 21= -1...12,8 barg 22= 0...20,7 barg 23= 1,86...43,0 barg 24= Livello liquido CAREL 25=0...60,0 barg 26=0...90,0 barg	Ratiometric: 4 = 0 to 17.3 barg	-	-	-	I	16	143	
A	Main control: 0= user defined 1= Centralized cabinet/cold room 2= Self contained cabinet/cold room 3= Perturbated cabinet/control room 4= Subcritical CO <sub>2</sub> cabinet/cold room 5= R404A condenser for subcritical CO <sub>2</sub> 6=AC or chiller with plate evaporator 7= AC or chiller with shell tube evaporator 8=AC or chiller with battery coil evaporator 9= AC or chiller with variable cooling capacity 10= AC or chiller perturbated unit 11= EPR Back pressure 12= Hot gas by-pass by pressure 13= Hot gas by-pass by temperature 14= transcritical CO <sub>2</sub> gas cooler 15= analog positioner (4 to 20 mA) 16= analog positioner (0 to 10 V) 17= AC/chiller or cabinet/cold room with adaptative regulation 18= AC or chiller with Digital Scroll compressor 19= AC/chiller with BLDC compressor (*) 20= superheat regulation with 2 temperature probes 21= I/O expander for pCO 22= Programmable SH regulation 23= Programmable special regulation 24= Programmable positioner 25= Evaporator liquid level regulation with CAREL sensor 26= Condenser liquid level regulation with CAREL sensor (*)= only for controls for CAREL valves	9= AC or chiller with variable cooling capacity	-	-	-	I	15	142	

user*	Parameter/description	Def.	Min.	Max.	UOM	Type **	CAREL	Modbus®	Notes
5rt A	Probe S2: 0= user defined 1= NTC CAREL 2= CAREL NTC- HT high 3= combined NTC SPKP**T0 4= 0 to 10V external signal 5=NTC-LTCAREL low temperature	1 = CAREL NTC	-	-	-	I	17	144	
A	Auxiliary control: 0= user defined 1= Disabled 2= high condensing temperature protection on S3 probe 3= modulating thermostat on S4 probe 4= backup probes on S3 and S4 5, 6, 7 = Reserved 8= Subcooling measurement 9= Inverse high condensation temperature protection on S3 probe 10= Reserved	Disabled	-	-	-	I	18	145	
A	Relay configuration: 1= Disabled 2= alarm relay (opened in case of alarm) 3= Solenoid valve relay (open in standby) 4= valve + alarm relay (opened in stand-by and control alarms) 5= Reversed alarm relay (closed in case of alarm) 6= Valve status relay (open if valve closed) 7= Direct command 8= Faulty closure alarm relay (opened if alarm) 9= Reverse faulty closure alarm relay (closed if alarm)	5 =Reversed alarm relay (closed in case of alarm)	-	-	-	I	12	139	
A	DI2 configuration: 1= Disabled 2= valve regulation optimization after defrost 3= Battery alarm management 4= Valve forced open (at 100%) 5= Regulation start/stop 6= Regulation backup 7= Regulation security	Disabled	-	-	-	I	10	137	
C	Display main var. 1: 1= Valve opening 2= Valve position 3= Current cool. capacity 4= Control set point 5= Superheat 6= Suction temperature 7= Evaporation temperature 8= Evaporation pressure 9= Condensing temperature 10= Condensing pressure 11= Modulating thermostat 12= EPR pressure 13= Hot gas bypass pressure 14= Hot gas bypass temperature 15= CO <sub>2</sub> gas cooler outlet temperature 16= CO <sub>2</sub> gas cooler outlet pressure 17= CO <sub>2</sub> gas cooler pressure set point 18= S1 probe measurement 19= S2 probe measurement 20= S3 probe measurement 21= S4 probe measurement 22= 4-20 mA input value 23= 0-10 V input value	Superheat	-	-	-	I	45	172	
C	Display main var. 2 (See display main var. 1)	Valve opening	-	-	-	I	46	173	

user*	Parameter/description	Def.	Min.	Max.	UOM	Type **	CAREL	Modbus®	Notes
C	S1 probe alarm manag.: 1= No action 2=Valve forced closed 3= Valve at fixed posit. 4= Use backup probe S3	Valve at fixed position	-	-	-	I	24	151	
C	S2 probe alarm manag.: 1= No action 2=Valve forced closed 3= Valve at fixed posit. 4= Use backup probe S4	Valve at fixed position	-	-	-	I	25	152	
C	S3 probe alarm manag.: 1= No action 2= Valve forced closed 3=Valve at fixed posit.	No action	-	-	-	I	26	153	
C	S3 probe alarm manag.: 1= No action 2= Valve forced closed 3= Valve at fixed posit.	No action	-	-	-	I	27	154	
C	Unit of measure: °C/K/barg; °F/psig	°C(K), barg	-	-	-	I	21	148	
A	DI1 configuration 1= Disabled 2= Valve regulation optimization after defrost 3= Discharged battery alarm management 4= Valve forced open (at 100%) 5= Regulation start/stop 6= Regulation backup 7= Regulation security	Regulation start/stop (tLAN-RS485) / Regulation backup (pLAN)	-	-	-	I	85	212	
A	Language: Italian; English	English	-	-	-	-	-	-	
PROBES									
C	S1 calibration offset	0	-85(-1233), -85	85(1233), 85	barg (psig) mA	A	34	33	
C	S1 calibrat gain on 4-20 mA	1	-20	20	-	A	36	35	
C	S1 pressure MINIMUM value	-1	-20 (-290)	S1 pressure MAXIMUM value	barg (psig)	A	32	31	
C	S1 pressure MAXIMUM value	9.3	S1 pressure MINIMUM value	200 (2900)	barg (psig)	A	30	29	
C	S1 alarm MIN pressure	-1	-20 (-290)	S1 alarm MAX pressure	barg (psig)	A	39	38	
C	S1 alarm MAX pressure	9.3	S1 alarm MIN pressure	200 (2900)	barg (psig)	A	37	36	
C	S2 calibration offset	0	-20 (-36), -20	20 (36), 20	°C (°F), volt	A	41	40	
C	S2 alarm MIN temperat	-50	-85(-121)	S2 alarm MAX temp.	°C(°F)	A	46	45	
C	S2 alarm MAX temperat	105	S2 alarm MIN temp.	200 (392)	°C(°F)	A	44	43	
CONTROL									
A	Superheat set point	6	LowSH: threshold	180 (324)	K(°R)	A	50	49	
A	Valve opening at start-up	50	0	100	%	I	37	164	
C	Valve opened in standby (0=disabled=valve closed; 1=enabled= valve open according to parameter "Valve position in stand-by")	1=enabled= valve open according to parameter "Valve position in stand-by"	0	1	-	D	23	22	

user*	Parameter/description	Def.	Min.	Max.	UOM	Type **	CAREL	Modbus®	Notes
C	Valve position in stand-by 0 = 25% 1...100% = % opening	50%	0	100	%	I	91	218	
C	start-up delay after defrost	10	0	60	min	I	40	167	
A	Pre-position time	6	0	18000	s	I	90	217	
A	Hot gas bypass temperature set point	10	-85(-121)	200 (392)	°C (°F)	A	28	27	
A	Hot gas bypass pressure set point	3	-20 (-290)	200 (2900)	barg (psig)	A	62	61	
A	EPR pressure set point	3.5	-20 (-290)	200 (2900)	barg (psig)	A	29	28	
C	PID proportional gain	15	0	800	-	A	48	47	
C	PID integral time	150	0	1000	s	I	38	165	
C	PID derivative time	5	0	800	s	A	49	48	
A	LowSH protection threshold	5	-40 (-72)	superheat set point	K(°F)	A	56	55	
C	LowSH protection integral time	15	0	800	s	A	55	54	
A	LOP protection threshold	-50	-85(-121)	MOP protection threshold	°C (°F)	A	52	51	
C	LOP protection integral time	0	0	800	s	A	51	50	
A	MOP protection threshold	50	LOP protection threshold	200 (392)	°C (°F)	A	54	53	
C	MOP protection integral time	20	0	800	s	A	53	52	
A	Enable manual valve position	0	0	1	-	D	24	23	
A	Manual valve position	0	0	9999	step	I	39	166	
C	Discharge superheat setpoint	35	-40(-72)	180 (324)	K (°F)	A	100	99	
C	Discharge temperature setpoint	105	-85(-121)	200 (392)	°C (°F)	A	101	100	
C	Liquid level perc. set point	50	0	100	%	A	118	117	
ADVANCED									
A	High Tcond threshold	80	-85(-121)	200 (392)	°C (°F)	A	58	57	
C	High Tcond integral time	20	0	800	s	A	57	56	
A	Modul thermost setpoint	0	-85(-121)	200 (392)	°C (°F)	A	61	60	
A	Modul thermost differential	0, 1	0.1 (0.2)	100 (180)	°C (°F)	A	60	59	
C	Modul thermost SHset offset	0	0 (0)	100 (180)	K (°F)	A	59	58	
C	CO <sub>2</sub> regul. 'A' coefficient	3.3	-100	800	-	A	63	62	
C	CO <sub>2</sub> regul. 'B' coefficient	-22.7	-100	800	-	A	64	63	
C	Start manual tuning 0 = no; 1= yes	0	0	1	-	D	39	38	-
C	Tuning method 0...100= automatic selection 101...141= manual selection 142...254=not accepted 255= PID parameters identified model	50	0	255	-	I	79	206	-
C	Network settings 0= 4800; 1= 9600; 2= 19200; 4 = 4800 bps; 5= 9600 bps; 6=19200 bps; 16=4800 bps; 17=9600 bps; 18=19200 bps; 20=4800 bps; 21=9600 bps; 22=19200 bps; 24=4800 bps; 25=9600 bps; 26= 19200 bps; 28=4800 bps; 29=9600 bps; 30= 19200 bps.	2	0	30	bit/s	I	74	201	CO
A	Power supply mode 0= 24 Vac; 1= 24 Vdc	0	0	1	-	D	47	46	
C	Enable mode single on twin (parameter disabled) 0= Twin; 1= Single	0	0	1	-	D	58	57	
C	Stop manual positioning if net error 0 = Normal operation; 1 = Stop	0	0	1	-	D	59	58	
C	Programmable regulation configuration	0	0	32767	-	I	101	228	
C	Programmable regulation input	0	0	32767	-	I	102	229	
C	Programmable SH regulation options	0	0	32767	-	I	103	230	
C	Programmable regulation set point	0	-800(-11603)	800(11603)	-	A	112	111	
C	Faulty closure alarm status 0/1=no/yes	0	0	1	-	D	49	48	

user*	Parameter/description	Def.	Min.	Max.	UOM	Type**	CAREL	Modbus®	Notes
ALARMS CONFIGURATION									
C	Low superheat alarm timeout (LowSH) (0= alarm DISABLED)	300	0	18000	s	I	43	170	
C	Low evap temp alarm timeout (LOP) (0= alarm DISABLED)	300	0	18000	s	I	41	168	
C	High evap temp alarm timeout (MOP) (0= alarm DISABLED)	600	0	18000	s	I	42	169	
C	High cond temp alarm timeout (High Tcond) (0= alarm DISABLED)	600	0	18000	s	I	44	171	
C	Low suction temperature alarm threshold	-50	-85 (-121)	200 (392)	°C(°F)	A	26	25	
C	Low suct temp alarm timeout (0= alarm DISABLED)	300	0	18000	s	I	9	136	
C	Alarm delay S1	0	0	240	s	I	131	258	
C	Alarm delay S2	0	0	240	s	I	132	259	
C	Alarm delay S3	0	0	240	s	I	133	260	
C	Alarm delay S4	0	0	240	s	I	134	261	
VALVE									
C	EEV minimum steps	50	0	9999	step	I	30	157	
C	EEV maximum steps	480	0	9999	step	I	31	158	
C	EEV closing steps	500	0	9999	step	I	36	163	
C	EEV nominal step rate	50	1	2000	step/s	I	32	159	
C	EEV nominal current	450	0	800	mA	I	33	160	
C	EEV holding current	100	0	250	mA	I	35	162	
C	EEV duty cycle	30	1	100	%	I	34	161	
C	EEV opening synchroniz.	1	0	1	-	D	20	19	
C	EEV closing synchroniz.	1	0	1	-	D	21	20	
<p>* User: A= Service (installer), C= Manufacturer.  **Type of variable: A= analogue, D= digital, I= integer</p>									

## 2J ECO DESIGN INFORMATION TABLES

Model(s): SMC 20 S/P			
Refrigerant fluid(s): R454C			
Item	Symbol	Value	Unit
Evaporating temperature	$t$	-10°C	°C
<b>Parameters at full load and ambient temperature 32°C</b>			
Rated cooling capacity	$P_A$	1.53	kW
Rated power input	$D_A$	0.83	kW
<b>Rated COP</b>	<b><math>COP_A</math></b>	<b>1.84</b>	
<b>Parameters at full load and ambient temperature 25°C</b>			
Cooling capacity	$P_2$	1.75	kW
Power input	$D_2$	0.79	kW
<b>Rated COP</b>	<b><math>COP_2</math></b>	<b>2.22</b>	
<b>Other items</b>			
Capacity control	Fixed		
Contact details	TEV Limited Amytage Road Brighouse HD61QF		

Model(s): SMC 30 S/P			
Refrigerant fluid(s): R454C			
Item	Symbol	Value	Unit
Evaporating temperature	$t$	-10°C	°C
<b>Parameters at full load and ambient temperature 32°C</b>			
Rated cooling capacity	$P_A$	1.78	kW
Rated power input	$D_A$	0.98	kW
<b>Rated COP</b>	<b><math>COP_A</math></b>	<b>1.82</b>	
<b>Parameters at full load and ambient temperature 25°C</b>			
Cooling capacity	$P_2$	1.97	kW
Power input	$D_2$	0.93	kW
<b>Rated COP</b>	<b><math>COP_2</math></b>	<b>2.12</b>	
<b>Other items</b>			
Capacity control	Fixed		
Contact details	TEV Limited Amytage Road Brighouse HD61QF		

Model(s): SMC 45 S/P			
Refrigerant fluid(s): R454C			
Item	Symbol	Value	Unit
Evaporating temperature	$t$	-10°C	°C
<b>Parameters at full load and ambient temperature 32°C</b>			
Rated cooling capacity	$P_A$	2.96	kW
Rated power input	$D_A$	1.36	kW
<b>Rated COP</b>	<b><math>COP_A</math></b>	<b>2.18</b>	
<b>Parameters at full load and ambient temperature 25°C</b>			
Cooling capacity	$P_2$	3.20	kW
Power input	$D_2$	1.24	kW
<b>Rated COP</b>	<b><math>COP_2</math></b>	<b>2.58</b>	
<b>Other items</b>			
Capacity control	Fixed		
Contact details	TEV Limited Amytage Road Brighouse HD61QF		

Model(s): SMC 50 S/P			
Refrigerant fluid(s): R454C			
Item	Symbol	Value	Unit
Evaporating temperature	<i>t</i>	-10°C	°C
<b>Parameters at full load and ambient temperature 32°C</b>			
Rated cooling capacity	<i>P<sub>A</sub></i>	4.17	kW
Rated power input	<i>D<sub>A</sub></i>	1.75	kW
<b>Rated COP</b>	<b><i>COP<sub>A</sub></i></b>	<b>2.38</b>	
<b>Parameters at full load and ambient temperature 25°C</b>			
Cooling capacity	<i>P<sub>2</sub></i>	4.49	kW
Power input	<i>D<sub>2</sub></i>	1.60	kW
<b>Rated COP</b>	<b><i>COP<sub>2</sub></i></b>	<b>2.81</b>	
<b>Other items</b>			
Capacity control	Fixed		
Contact details	TEV Limited Amytage Road Brighouse HD61QF		

Model(s): SMC 80 3/P			
Refrigerant fluid(s): R454C			
Item	Symbol	Value	Unit
Evaporating temperature	<i>t</i>	-10°C	°C
Annual electricity consumption	<i>Q</i>	9757	kWh/a
Seasonal energy performance ratio	<i>SEPR</i>	3.34	
<b>Parameters at full load and ambient temperature 32°C (Point A)</b>			
Rated cooling capacity	<i>P<sub>A</sub></i>	5.300	kW
Rated power input	<i>D<sub>A</sub></i>	2.180	kW
<b>Rated COP</b>	<b><i>COP<sub>A</sub></i></b>	<b>2.43</b>	
<b>Parameters at part load and ambient temperature 25°C (Point B)</b>			
Declared cooling capacity	<i>P<sub>B</sub></i>	5.73	kW
Declared power input	<i>D<sub>B</sub></i>	1.98	kW
<b>Rated COP</b>	<b><i>COP<sub>B</sub></i></b>	<b>2.89</b>	
<b>Parameters at part load and ambient temperature 15°C (Point C)</b>			
Declared cooling capacity	<i>P<sub>C</sub></i>	6.32	kW
Declared power input	<i>D<sub>C</sub></i>	1.75	kW
<b>Rated COP</b>	<b><i>COP<sub>C</sub></i></b>	<b>3.61</b>	
<b>Parameters at part load and ambient temperature 5°C (Point D)</b>			
Declared cooling capacity	<i>P<sub>D</sub></i>	6.86	kW
Declared power input	<i>D<sub>D</sub></i>	1.58	kW
<b>Rated COP</b>	<b><i>COP<sub>D</sub></i></b>	<b>4.34</b>	
<b>Other items</b>			
Capacity control	Fixed		
Degradation coefficient for fixed and staged capacity units	<i>C<sub>dc</sub></i>	0.25	
Contact details	TEV Limited Amytage Road Brighouse HD61QF		

## 2K COMPONENT IDENTIFICATION SMC+

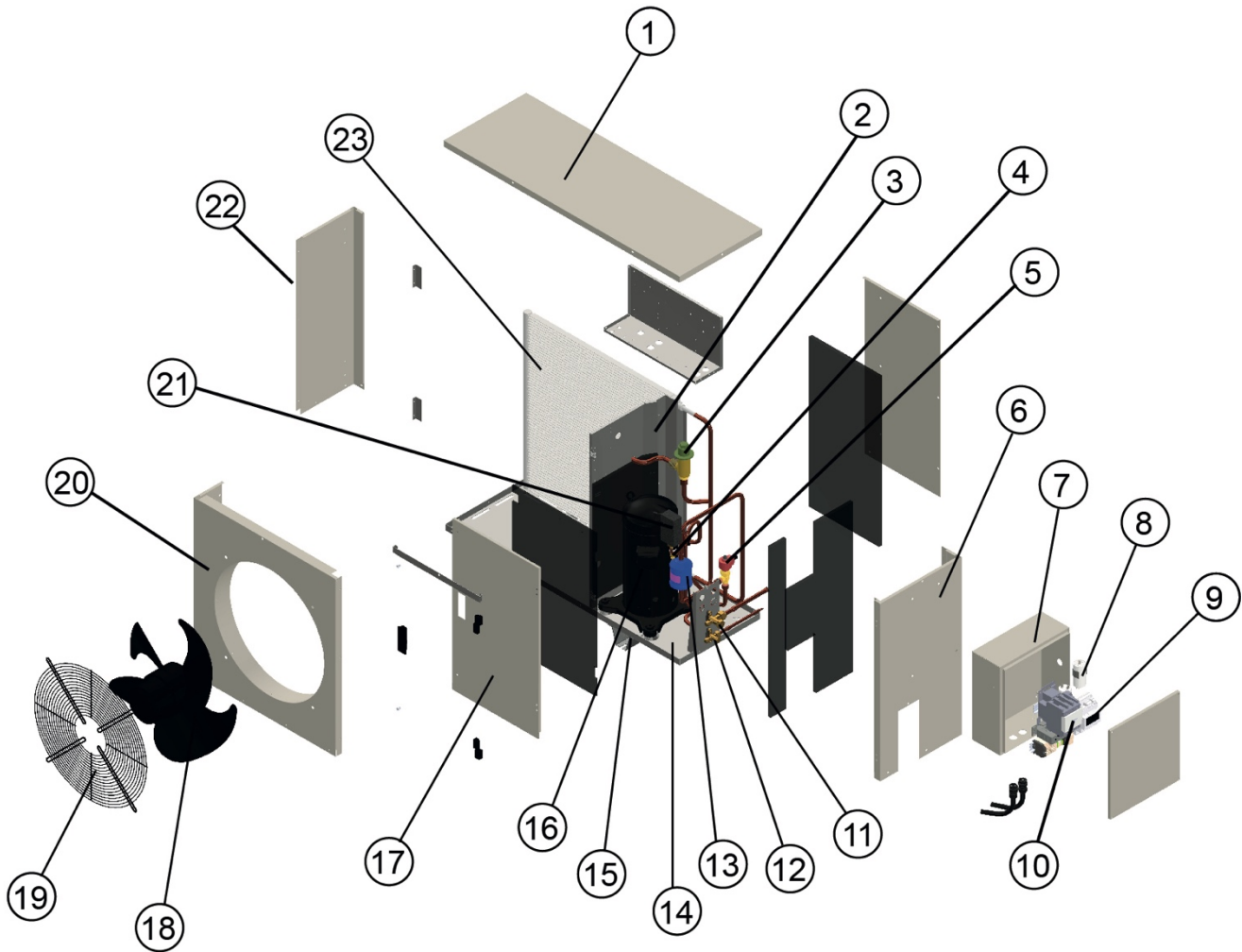

1	LID	9	ELECTRONIC EXPANSION VALVE DRIVER	17	HINGED DOOR
2	BULKHEAD PANEL	10	CONTACTOR	18	FAN / MOTOR ASSEMBLY
3	PRESSURE RELEASE VALVE	11	SERVICE VALVE (SUCTION)	19	FAN GUARD
4	SEPARATE HP AND LP SWITCHES	12	SERVICE VALVE (LIQUID/EXPANSION)	20	FASCIA PANEL
5	ELECTRONIC EXPANSION VALVE	13	DRIER	21	FAN SPEED CONTROLLER
6	SIDE PANEL	14	BASE	22	CORNER PANEL
7	EXTERNAL ELECTRICS BOX	15	MOUNTING FOOT	23	MICRO CHANNEL COIL
8	COMPRESSOR CAPACITOR	16	COMPRESSOR		

## 2L CONDENSING UNIT MAINTENANCE

The refrigerant recovery section of the risk assessment template or equivalent should be carried out before commencing refrigerant recovery.

Before engaging in any maintenance or repairs ensure

- Use of trained certified natural persons\*.
- Well ventilated working environment.
- Use of a flammable gas leak detector.
- Correct selection of tools and equipment compatible with A2L refrigerants.
- Recovery of remaining refrigerant.
- Purging pipework with a suitable inert gas, prior to, during and for a suitable period after carrying out flame brazing to ensure that a flammable mixture cannot be formed.
- Adequate fire watch.
- Pressure testing of repair in accordance with EN378.
- Evacuation and dehydration in accordance with EN 378.
- Charging of the system in accordance with EN 378.
- Leak checking of the repair and system in accordance with EN 1516/2017.

Any other information identified within the site-specific risk assessment is available and taking into account.

**\*NOTE: it is the responsibility of the operator to ensure the technician is certified to the correct standard (EN13313 or equivalent).**

### **IMPORTANT ISOLATE THE UNIT PRIOR TO COMMENCING ANY MAINTENANCE OR REPAIR WORK**

#### **GENERAL**

1. Ensure unit is not blocked or enclosed and there is adequate free airflow in and round the condensing unit.
2. Visually inspect the unit for wear and tear.
3. Remove the access panels (retain the screws).
4. Clean the base and insides of the unit.
5. Check all electrical connections are secure.
6. Check the face of the coil for cleanliness. Comb the fins if necessary.
7. Check the tightness of the compressor fixing bolts.
8. Check the fan rotates freely.
9. Check the pipework insulation condition.
10. Suction and discharge pressure.
11. Operation of head pressure control.
12. Visually check for oil patches.
13. Check safety labels are clear

## 3 – EVAPORATORS

### 3A COMPONENT IDENTIFICATION

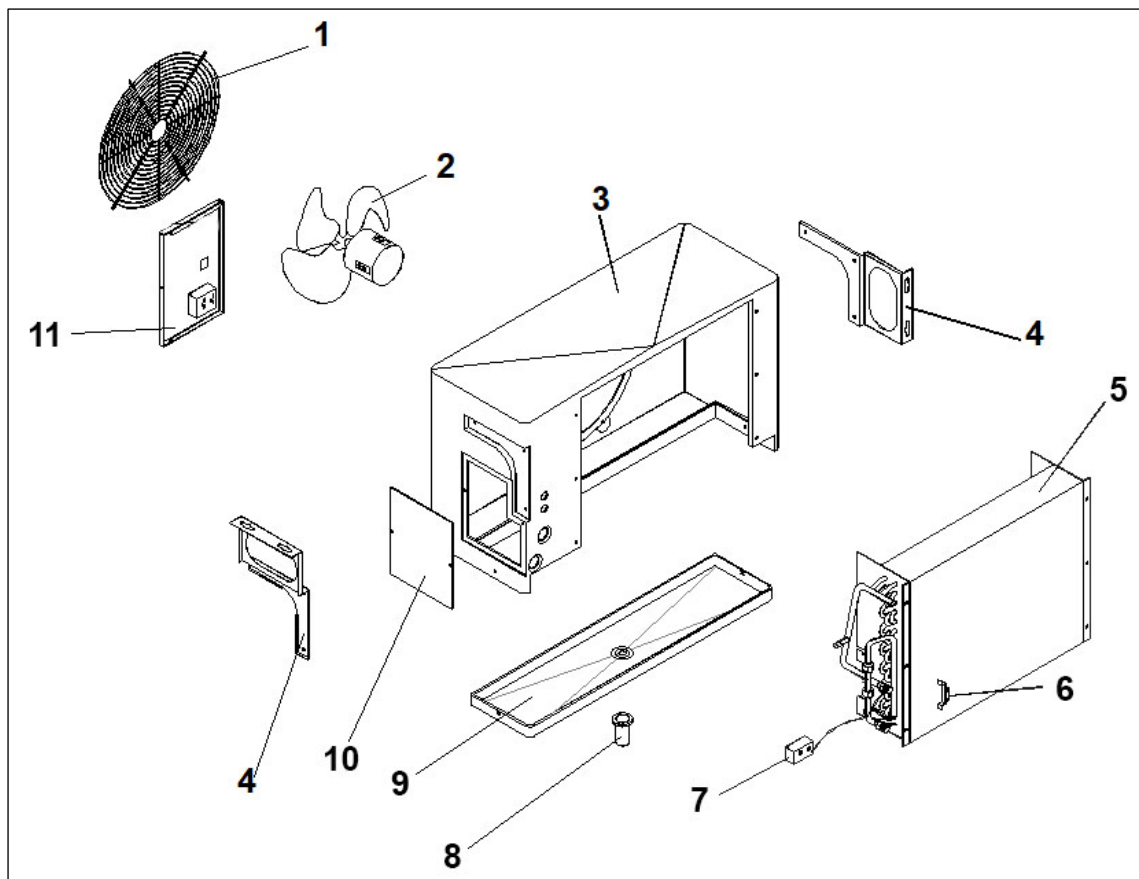

1	Grille	7	De-ice stat (option)
2	Fan / motor	8	Drain stub adaptor
3	Case	9	Drain tray
4	Wall / ceiling mounting brackets	10	Side access panel
5	Coil assembly	11	Electrics box door
6	Thermostat bulb & bracket		

**3B UNIT DIMENSIONS**

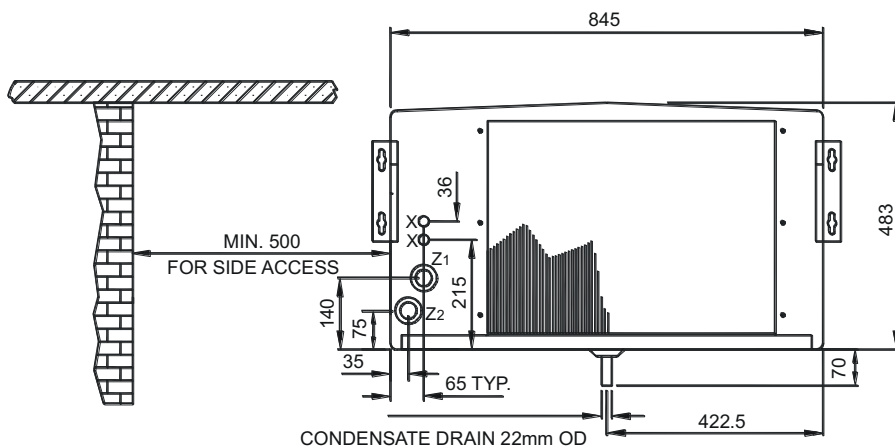
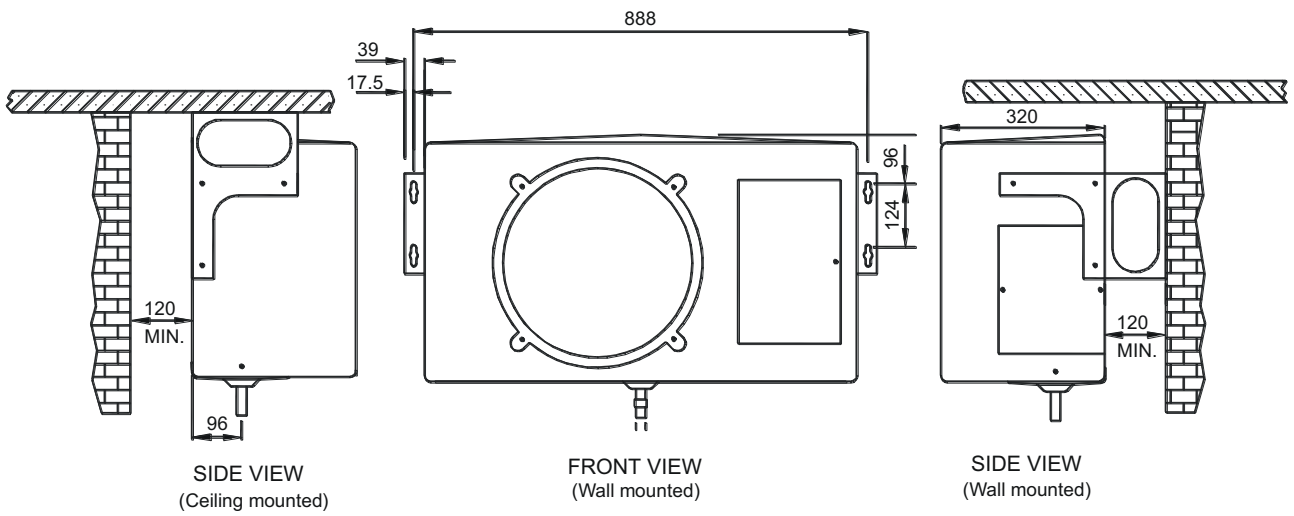
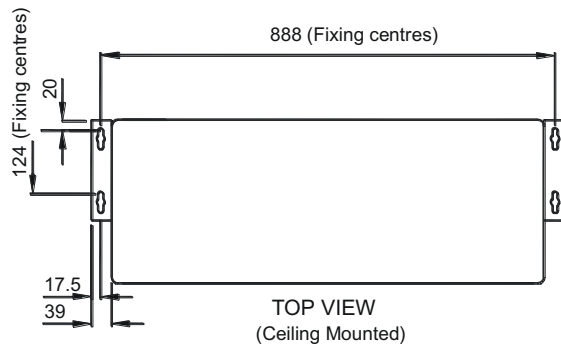

X = Interconnecting Wiring  
 Z<sub>1</sub> = Suction  
 Z<sub>2</sub> = Liquid / Expansion

REAR VIEW  
(Wall mounted)

DIMENSIONS (mm)

## 3C SPECIFICATION

## AIR FLOWS

MODEL	m <sup>3</sup> /s
CXE 30	0.61
CXE 40	0.61
CXE 50	0.66
CXE 70	0.58

## SOUND POWER AND SOUND PRESSURE LEVELS

## INDOOR UNIT

MAXIMUM SPEED	SOUND POWER LEVELS						SOUND PRESSURE LEVELS
	Frequency Hz						
	125	250	500	1K	2K	4K	
CXE 30	69.1	67.7	67.6	65.6	62.2	56.0	dB(A)
CXE 40	69.1	67.7	67.6	65.6	62.2	56.0	39
CXE 50	71.7	69.2	69.1	67.1	63.2	58.5	39
CXE 70	70.1	68.2	68.6	66.1	63.2	57.5	40.5
							39.9

Sound Pressure Levels in dB(A) at 10m distance in free field conditions. (Reference  $2 \times 10^{-5} \text{ N/m}^2$ )

## UNIT ELECTRICAL LOADS [230V 50Hz 1Ph (A)]

MODEL	FAN MOTOR
CXE 30	0.8
CXE 40	0.8
CXE 50	0.8
CXE 70	0.8

### 3D EVAPORATOR INSTALLATION

When installing a cellar cooling system utilising an A2L refrigerant it is important to ensure that sufficient free space is allowed around the evaporator. The correct amount of space will ensure that, in the unlikely event of a leak occurring, a flammable mixture is not created.

## INSTALLATION

CONTENTS		
PARTS DESCRIPTION	QTY	ACTION
Envelope containing operating instructions and	1	Pass to the end user.
Mounting brackets	2	Use to hang unit.

Drain Stub/Nut/Gasket		1	Fitted by installer.
Drain stub adaptor		1	Convert to 3/4" drain if required.
Screw M5		6	To fix brackets to unit.
Washer nylon		6	To fix brackets to unit.
Washer M5 shakeproof		6	To fix brackets to unit.

The unit may be mounted on a wall or solid ceiling using brackets supplied. It should be matched with the appropriately sized outdoor unit; this instruction should be used in conjunction with the outdoor unit installation instructions.

### UNIT COMBINATIONS

Minimum Set Temperature 8°C	
INDOOR UNIT	OUTDOOR UNIT
CXE 30	SMC 20
CXE 40	SMC 30
CXE 50	SMC 45
CXE 70	SMC 50
CXE 70	SMC 80

1. Fit all kits prior to installing the unit.
2. Ensure that the mounting surface will support the operating weight of the unit.
3. Mark out the mounting positions and drill holes to suit 6mm rawlbolt shields or equivalent strength fasteners (ensure that the unit is positioned to give sufficient access (min 0.5m) to the removable side panel).
4. Fix the mounting brackets to the unit in the correct position for wall or ceiling mounting.
5. Raise the unit into position and secure the fixings, ensuring that it is square and level.
6. Remove the drain tray then fit the drain stub, nut & gasket. Refit the drain tray

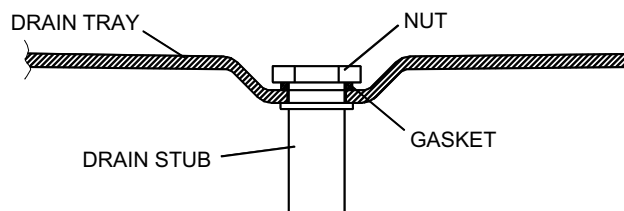

### NITROGEN CHARGE

The unit contains a small charge of dry nitrogen, which should be discharged into the atmosphere. This is a non-toxic, non-ozone depleting gas with no global warming potent

### 3E EVAPORATOR OPERATION

Persons working in and around the cellar cooler must ensure that sources of ignition are not brought into the area. Loading and unloading of product should be carried in a way to ensure that damage to the refrigeration containing components cannot occur. Smoking and naked flames should be prohibited within the cellar and the area around the condensing (outdoor) unit.

In the rare case of a leak occurring. Immediately contact an F Gas approved refrigeration technician. Do not open the door to the cellar. Keeping the door closed will help to maintain the storage temperature of the product and prevent a potentially flammable mixture leaking into to the environment outside the cellar. If product has to be removed from the cellar to be moved to another refrigerated storage facility, please undertake the following procedure:

1. Keep unauthorised personnel away
2. Ensure no smoking, no naked flame and no other potential sources of ignition are present
3. Make sure there is adequate ventilation
4. Open the door to the cellar
5. Wait 30 seconds before entering the cellar
6. Remove product from the cellar as quickly as possible
7. Close the cellar and do not re-enter until the refrigeration technician says that it is safe to do so

If the leak is identified as occurring outside the cellar, but inside a building or enclosure, ensure adequate ventilation. No source of ignition shall be energised or brought into the area until the environment is proven to be safe.

TEMPERATURE CONTROL (Do not set the controller below 4°C.)

The SET temperature is factory set at 12°C.

The digital display normally displays the return air temperature.

#### Parameters

Code	Function	Set Range	Default Value	Note
F1	Temperature Set Value	-50.0 - 99.9°C	10.0°C	<b>Factory Set to 12.0°C</b>
F2	Difference Set Value	0.3 – 10.0°C	0.5°C	<b>Factory Set to 1.0°C</b>
F3	Compressor Delay Time	1 – 10 Minutes	3 Minutes	
F4	Temperature Calibration Value	-10.0 – 10.0°C	0°C	

**PLEASE NOTE: On site only parameter F1 (Temperature Set Point) should be changed to suit site conditions. The other parameters should not be changed.**

#### Changing Parameters

To change parameter values do the following:

To scroll through parameters, Press the 'S' key for 3s or more to enter parameter modifying mode. The set indicator light will illuminate, the screen will display the first menu code 'F1'.

Press and hold both the 'S' key and '▲' or '▼' to adjust values as required.

To save the parameter quickly press and release the '⏻' key to instantly save the modified parameter value and return to display the normal temperature value on the controller.

**Please Note: After modifying parameter values if no keys are pressed within 10 seconds then the controller won't save the modified parameter and the screen will return to display temperature.**

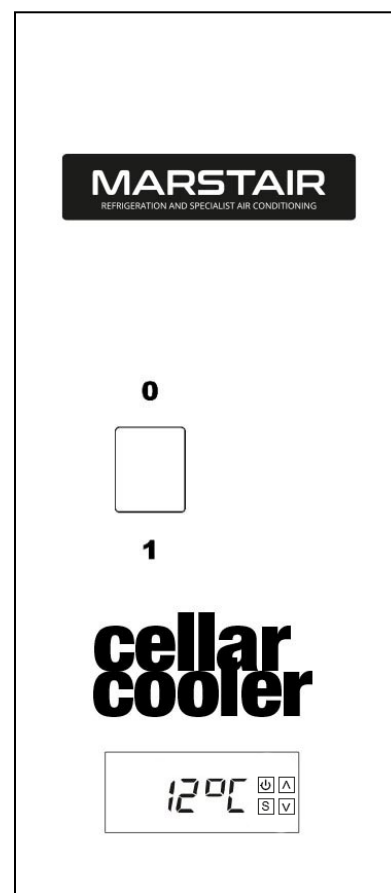

### 3F MAINTENANCE

The refrigerant recovery section of the risk assessment template or equivalent should be carried out before commencing refrigerant recovery.

Before engaging in any maintenance or repairs ensure

- o Use of trained certified natural persons\*.
- o Well ventilated working environment.
- o Use of a flammable gas leak detector.
- o Correct selection of tools and equipment compatible with A2L refrigerants.
- o Recovery of remaining refrigerant.
- o Purging pipework with a suitable inert gas, prior to, during and for a suitable period after carrying out flame brazing to ensure that a flammable mixture cannot be formed.
- o Adequate fire watch.
- o Pressure testing of repair in accordance with EN378.
- o Evacuation and dehydration in accordance with EN 378.
- o Charging of the system in accordance with EN 378.
- o Leak checking of the repair and system in accordance with EN 1516/2017.

Any other information identified within the site specific risk assessment is available and taking into account.

\*NOTE: it is the responsibility of the operator to ensure the technician is certified to the correct standard (EN13313 or equivalent).

Regular inspection and periodic maintenance is enough to ensure long time usage.

- Make sure all electric connections are tightened.
- Make sure all fan screws are tightened.
- Make sure each fan is running freely.
- Make sure heat exchanger mounting is level and stable.
- Make sure that the system is evacuated well from air. There should not be air pockets inside of the coil.
- Cables should not be affected by heat of resistance.
- Make sure drainage water easily flows away. Please see water flows away easily with opening drain pan and side cover.
- Check safety labels are clear

System is to be switched off and isolated during any repairs

### **3G ALARM INSTALLATION**

A method of alarm is required identify a potential loss of gas. This can be a cellar temperature "out of limits" alarm, or something more specific like a gas leak detector.

In the case of a leak the alarm should as a minimum either: -

- Alarm lamp flashing or lighting
- Alarm horn sounding
- Display warning on equipment controller

If leak detection is installed, it should be either the sensor type or via existing pressure sensing devices. The leak detection method (sensor type), needs to be calibrated/tested annually and sensitive to < 20% of the lower flammability level of the refrigerant. If the detector uses a drop in pressure, then it needs to be tested for correct operation. If a pressure type of detector is used, due to the inaccuracy of this method, the operator should assume that a flammable mixture could be present within the cellar and appropriate action must be taken

### 3H EVAPORATOR WIRING DIAGRAM

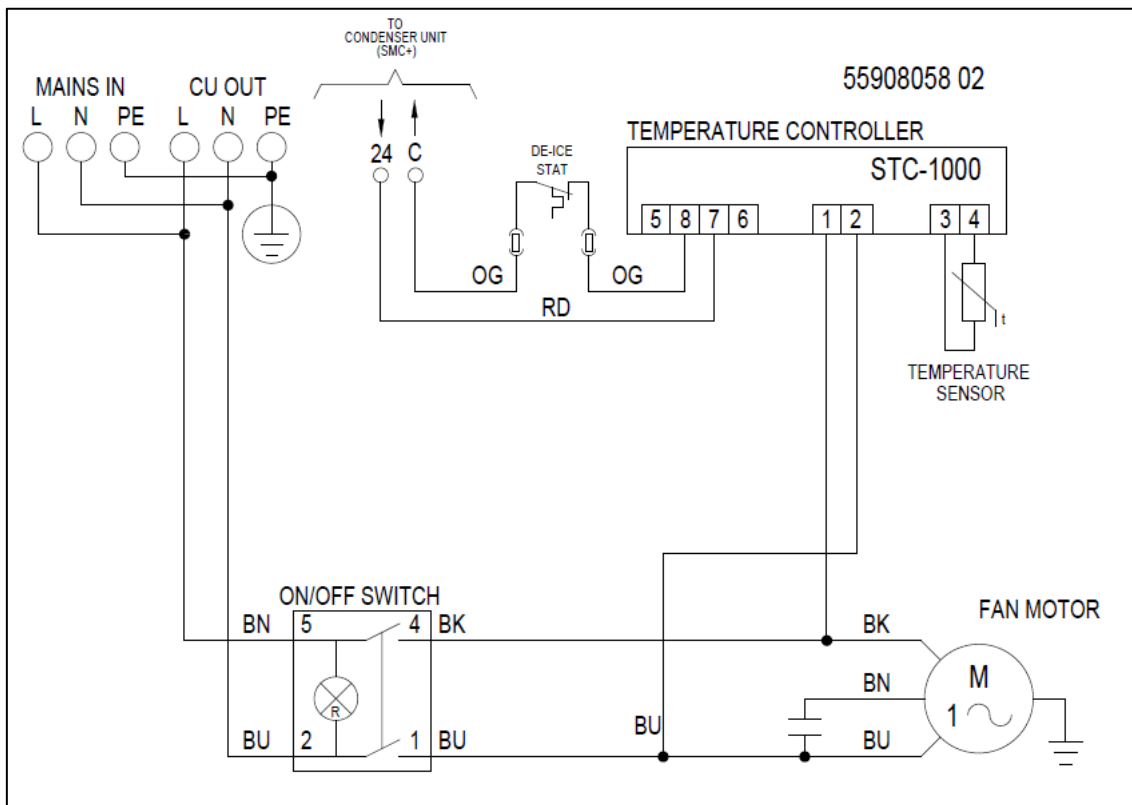

### 3I REFRIGERANT SYSTEM SCHEMATIC DIAGRAM

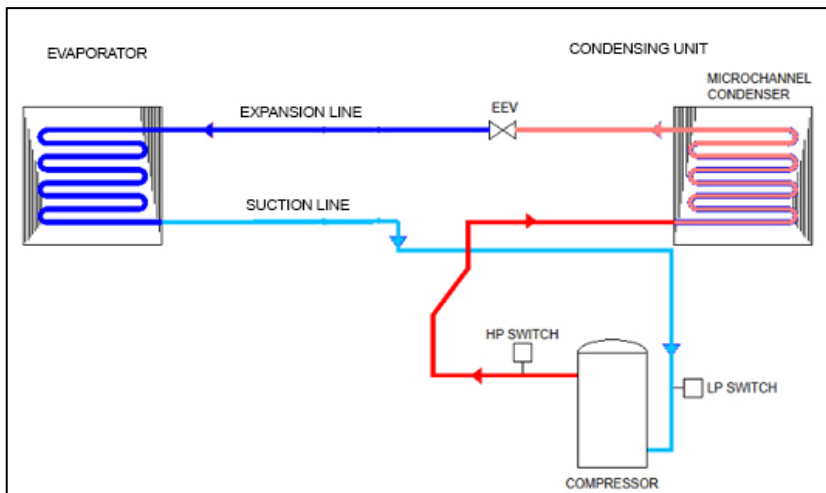

## 4 – SYSTEM SELECTION PROCESS

1. Find minimum room size acceptable based on EN 378 = refrigerant charge (kg) / (lower flammability limit X 0.2) in the tables below
2. Check whether your cellar size is bigger – If it is, that's great you can move on to the next part if not try the following:-
  - a. Reducing your pipe run
  - b. Use 2 smaller systems instead of 1 big system.

R454C (12.7°C return Air / 32°C External)											
Cooling kW	Condensing unit	CXE A2L	System charge 0m	5m Pipe Run		10m Pipe Run		15m Pipe Run		20m Pipe Run	
				System charge	BS EN 378 Minimum Room Size m <sup>3</sup>	System charge	BS EN 378 Minimum Room Size m <sup>3</sup>	System charge	BS EN 378 Minimum Room Size m <sup>3</sup>	System charge	BS EN 378 Minimum Room Size m <sup>3</sup>
2.4	SMC+20	30	0.295	0.375	6.4	0.455	7.8	0.535	9.1	0.615	10.5
2.7	SMC+30	30	0.320	0.400	6.8	0.480	8.2	0.560	9.6	0.640	10.9
4.4	SMC+45	50	0.655	0.735	12.5	0.815	13.9	1.105	18.9	1.255	21.4
6.2	SMC+50	70	0.760	0.840	14.3	1.060	18.1	1.210	20.7	1.360	23.2
7.4	SMC+80	70	0.970	1.050	17.9	1.270	21.7	1.420	24.2	1.570	26.8

## 5 – SPARES

Products for spare parts, please ensure the use of official Marstair spares. Any spare parts taken from other companies, Marstair will not be responsible in case of any damage and will be out of warranty.

## 6 – END OF LIFE REQUIRMENTS

Refrigerant must be recovered by a certificated technician before the plant is dismantled. Modern refrigerant recovery machines should be able to remove well over 95% of the refrigerant in an old system.

All recovered refrigerants can either be:

- Sent for destruction by incineration at a licenced waste facility
- Sent to a specialist plant that can re-process the old refrigerant into a gas with properties identical to virgin refrigerant, to create “reclaimed refrigerant”
- Given a basic cleaning process, to create “recycled refrigerant”

Given the refrigerant supply shortage that will be created by the phase down process, it is worth trying to send the old refrigerant for reclamation as it may have a good residual value. If the old refrigerant is too contaminated it cannot be reclaimed and must be sent for destruction. It is important not to mix different gases in the same recovery cylinder – as this would render them unsuitable for reclamation.

Reclaimed refrigerant can be used in any refrigeration equipment. Recycled refrigerant must always be used with care as it may be contaminated or of unknown composition.

## 7 – INSTALLATION RISK ASSESSMENT

### Installation of an A2L Split Cellar System

Prior to installation, it is important to ensure that the location is suitable for this type of system and that the instructions have been followed with regard to the minimum room volume for the maximum charge weight. This assessment process is designed to augment a detailed risk assessment not replace it.

The A2L DSEAR Assessment has identified that if a cellar split system (typically less than 3kg refrigerant charge), is located correctly in accordance with the instructions, then the most likely point of leakage is a flare connection on the condensing unit, which will be located in free air outside. This will result in Zone 2 NE.

BS EN 60079-10-1 states that this zone may be treated as non-hazardous. Such a zone implies that an explosion, if it takes place, will have negligible consequences.

The following step by step assessment assumes that the site in which you are working has no specific risks or hazards. If this is not the case, a full assessment will be required

## INSTALLATION

Question	N/A	YES	NO	Comments
1. Has correct PPE been selected?				If yes go to question 2 If no stop assessment
2. Are suitable first aid facilities available?				If yes go to question 3 If no stop assessment
3. Has the electrical supply been suitably isolated?				If yes go to question 4 If no rectify and reassess
4. Are hot works required for jointing of the refrigeration pipework?				If yes go to question 7 If no go to question 5
5. Are permanent mechanical joints required?				If yes go to question 20 If no go to question 6
6. Have the flare connections been made to a suitable standard?				If yes go to question 20 If no rectify and reassess
7. Are you competent to carry out brazing tasks?				If yes go to question 8 If no stop assessment
8. Brazing certificate number				
9. Has a suitable fire extinguisher been selected and a hot work permit been issued?				If yes go to question 10 If no stop assessment
10. Is the area adequately ventilated?				If yes go to question 11 If no stop assessment
11. Are the pressure regulators in date?				If yes go to question 12 If no rectify and reassess
12. Are the flash back arrestors in date?				If yes go to question 13 If no rectify and reassess
13. Has the oxyfuel equipment been leak tested?				If yes go to question 14 If no rectify and reassess
14. Has the Oxygen Free Nitrogen equipment been leak tested?				If yes go to question 15 If no rectify and reassess
15. Are all the cylinders upright and secure?				If yes go to question 16 If no rectify and reassess
16. Is Oxygen Free Nitrogen purging at the correct flow rate through the pipework?				If yes go to question 17 If no rectify and reassess
17. Has a full shutdown of equipment been completed upon conclusion of hot works?				If yes go to question 18 If no rectify and reassess
18. Is a fire watch to be undertaken?				If yes go to question 19 If no rectify and reassess
19. Duration of fire watch				

## PRESSURE TESTING

20. F Gas certificate number				
21. Is the system to be pressure tested with Oxygen Free Nitrogen?				If yes go to question 22 If no rectify and reassess
22. What is the required strength pressure test?				
23. What is the required tightness pressure test?				
24. Has the pressure been incrementally increased in a safe manner?				If yes go to question 25 If no rectify and reassess
25. Has the system passed the strength test?				If yes go to question 26

				If no rectify and reassess
26. Has the system passed the tightness test?				If yes go to question 27 If no rectify and reassess
27. What was the duration of the tightness test?				
28. Has the system been safely de-pressurised into a well ventilated environment?				If yes go to question 29 If no rectify and reassess

## EVACUATION

29. Has a flammable gas leak detector been energised and placed in a suitable location?				If yes go to question 30 If no rectify and reassess
30. Have all possible ignition sources been removed from the work area?				If yes go to question 31 If no rectify and reassess
31. Has a suitable vacuum pump been fitted to the system?				If yes go to question 32 If no rectify and reassess
32. Is the oil level satisfactory?				If yes go to question 33 If no rectify and reassess
33. Is the exhaust able to be discharged into a safe environment away from ignition source?				If yes go to question 34 If no rectify and reassess
34. Has a vacuum gauge been connected to the system?				If yes go to question 35 If no rectify and reassess
35. Has a suitable vacuum been achieved and held for a suitable period of time?				If yes go to question 36 If no rectify and reassess

## CHARGING OF REFRIGERANT

36. Is additional refrigerant charge required?				If yes go to question 37 If no go to question 44
37. Is a suitable charging cylinder available fitted with the correct bottle adaptor?				If yes go to question 38 If no rectify and reassess
38. Have you selected a calibrated weighing platform?				If yes go to question 39 If no rectify and reassess
39. Calibration certificate number				
40. Has the charging hose been evacuated of air?				If yes go to question 41 If no rectify and reassess
41. Will the system be charged in liquid or vapour form?				
42. Has the correct additional charge been added in accordance with the manufacturers instructions?				If yes go to question 43 If no rectify and reassess
43. Can the equipment be energised to remove refrigerant from the charging hoses?				If yes go to question 44 If no rectify and reassess
44. Have the isolation valves been opened correctly?				If yes go to question 45 If no rectify and reassess
45. Has the system been leak checked with a suitable leak detector for A2L refrigerant?				If yes go to question 46 If no rectify and reassess
46. Have the running conditions of the system been checked/recorded?				If yes go to question 47 If no rectify and reassess
47. Have the charging hoses been removed safely and with minimum loss of refrigerant?				If yes go to question 48 If no rectify and reassess
48. Is the service valve leak free and cap replaced?				If yes go to question 49 If no go to question 50

## REFRIGERANT RECOVERY

49. Have all of the tools, refrigerant and equipment been removed from site?				If yes end assessment If no rectify and reassess
50. Is the area adequately ventilated?				If yes go to question 51

				If no rectify and reassess
51. Has a suitable flammable gas leak detector been energised and placed at a low level?				If yes go to question 52 If no rectify and reassess
52. Has a suitable recovery unit been fitted?				If yes go to question 53 If no rectify and reassess
53. Do you have a suitable recovery cylinder with adequate capacity?				If yes go to question 54 If no rectify and reassess
54. Have you placed it on to a suitable calibrated weighing platform?				If yes go to question 55 If no rectify and reassess
55. Calibration certificate number				
56. Have you documented the amount of refrigerant recovered and filled out the appropriate paperwork?				If yes go to question 57 If no rectify and reassess
57. Identify source of leakage and recommence assessment procedure.				

This information is to be given to the end user along with any other risks identified.