

MARSTAIR

REFRIGERATION AND SPECIALIST AIR CONDITIONING

TECHNICAL MANUAL & INSTALLATION INSTRUCTION

SEE ALSO 56408020 INTERCONNECTING INSTRUCTIONS

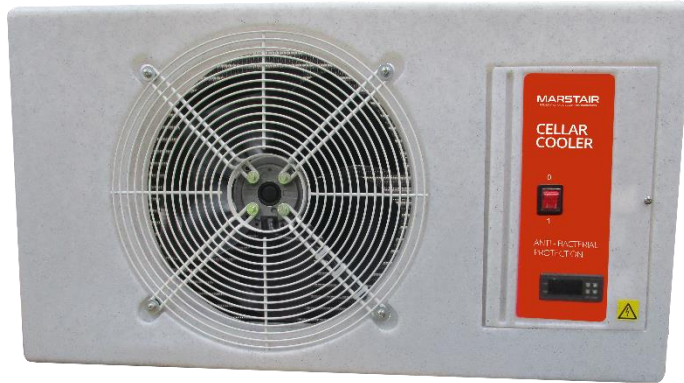

17 Series
Cellar
Cooler

R410A

GENERAL

1. TEV Ltd recommend that personnel working on this equipment be skilled and fully conversant with the appropriate Air Conditioning, Refrigeration and Electrical practices and have sound knowledge of current Industrial Safe Working practices.
2. These units contain live electrical components, moving parts and refrigerant under pressure. Always site out of reach of children and protect from vandalism.
3. The data plate only gives information for the particular unit. For system details add input power and current of indoor and outdoor unit, including any heater load.
4. NOTE: The New 17 series CKA's are pre-charged for 7.5 metre pipe run. The older models of the CKA's have a small nitrogen charge. Please check before installation.

CX(E)A & CKA SYSTEMS

DIMENSIONS & WEIGHTS

All dimensions in mm

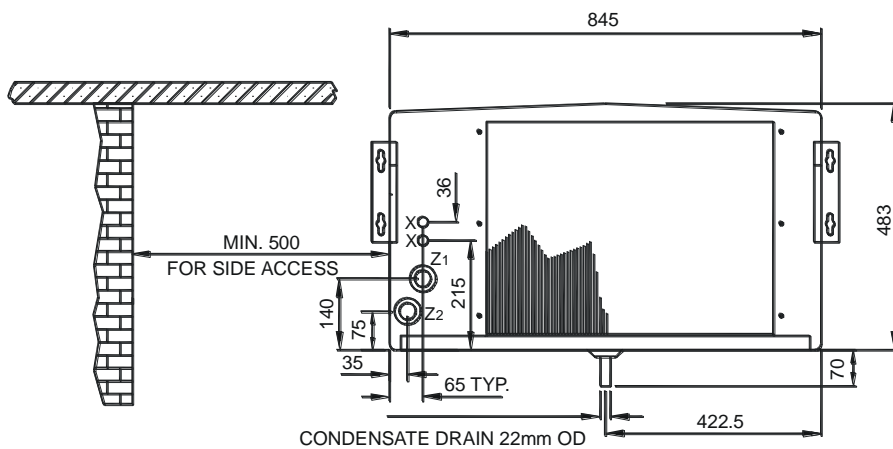
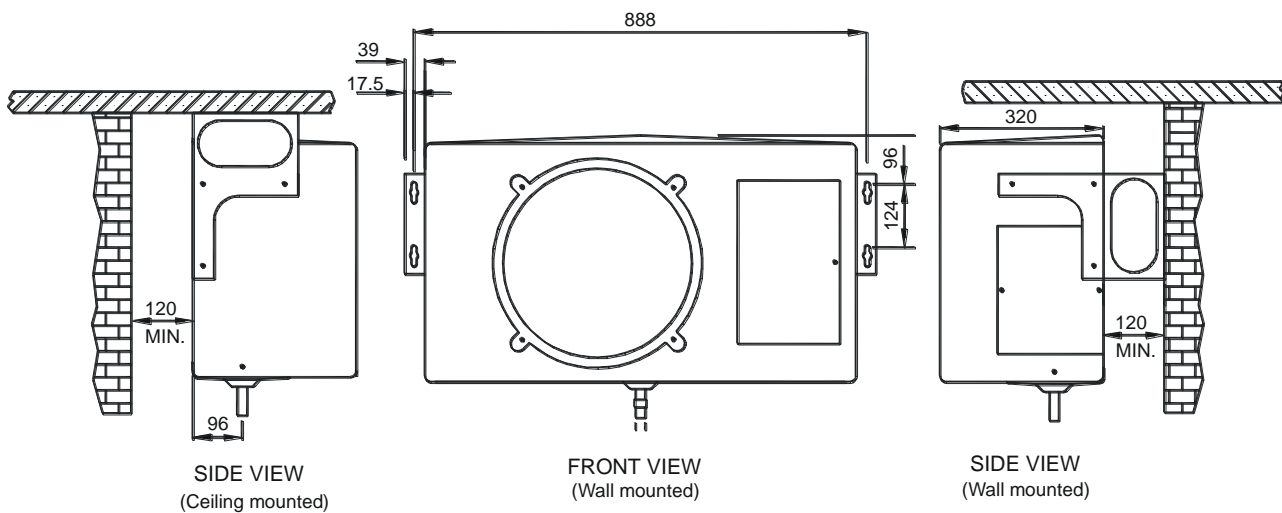
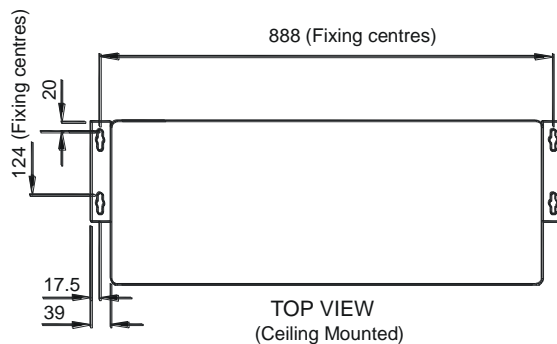

X = Interconnecting Wiring
 Z₁ = Suction
 Z₂ = Liquid / Expansion

REAR VIEW
(Wall mounted)

DIMENSIONS (mm)

Model	Weight (kg)
CX(E)A 30	18
CX(E)A 50	20
CX(E)A 70	23

CKA ARRANGEMENT

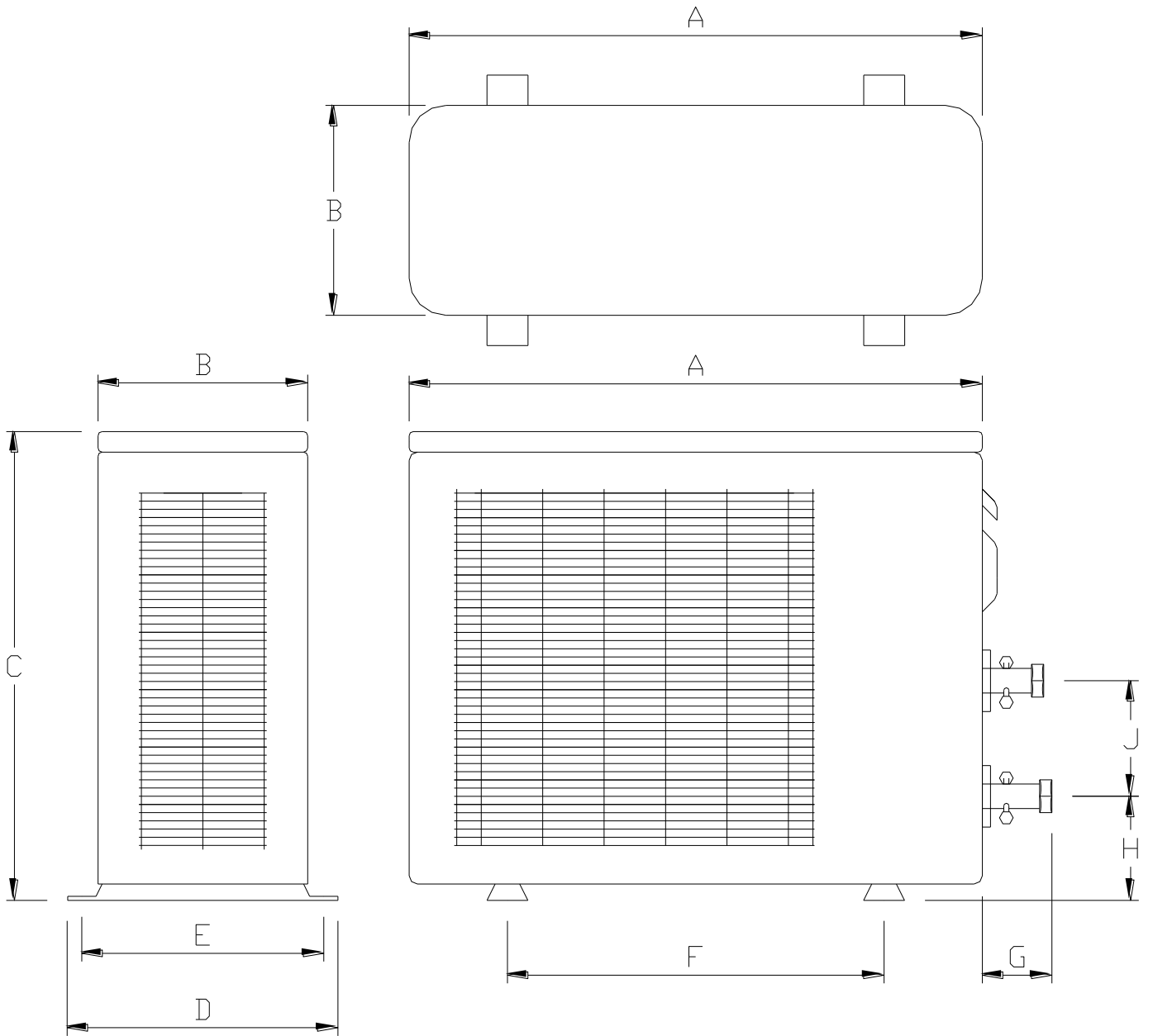

	CKA 35	CKA 50	CKA 70
A (mm)	760	760	860
B (mm)	256	256	307
C (mm)	552	552	660
D (mm)	330	330	370
E (mm)	290	290	340
F (mm)	510	510	630
G (mm)	50	50	50
H (mm)	85	85	85
J (mm)	70	70	70
WEIGHT	35Kg	42Kg	56Kg
Valve Size LIQUID (upper)	1/4"	1/4"	3/8"
Valve Size SUCTION (lower)	1/2"	1/2"	5/8"

INSTALLATION

CONTENTS		
PARTS DESCRIPTION	QTY	ACTION
Envelope containing operating instructions and Declaration of Conformity	1	Pass to the end user.

Drain Stub/Nut/Gasket		1	Fitted by installer.
Drain stub adaptor		1	Convert to 3/4" drain if required.
Screw M5		6	To fix brackets to unit.
Washer nylon		6	To fix brackets to unit.

The unit may be mounted on a wall or solid ceiling using brackets supplied. It should be matched with the appropriately sized outdoor unit; this instruction should be used in conjunction with the outdoor unit installation instructions.

UNIT COMBINATIONS

Minimum Set Temperature 8°C	
INDOOR UNIT	OUTDOOR UNIT
CX(E)A 30	CKA35
CX(E)A 50	CKA35
CX(E)A 50	CKA50
CX(E)A 70	CKA70

1. Fit all kits prior to installing the unit. (Heater kit is easier to fit when unit has been mounted).
2. Ensure that the mounting surface will support the operating weight of the unit (see table below).
3. Mark out the mounting positions and drill holes to suit 6mm rawlbolt shields or equivalent strength fasteners (ensure that the unit is positioned to give sufficient access (min 0.5m) to the removable side panel).
4. Fix the mounting brackets to the unit in the correct position for wall or ceiling mounting.
5. Raise the unit into position and secure the fixings, ensuring that it is square and level.
6. Remove the drain tray then fit the drain stub, nut & gasket. Refit the drain tray.

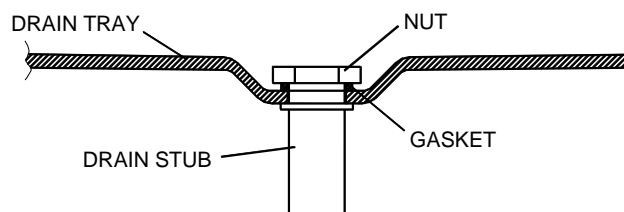

NITROGEN CHARGE

The indoor units CX(E)A contain a small charge of dry nitrogen, which should be discharged into the atmosphere. This is a non-toxic, non-ozone depleting gas with no global warming potential.

The new 17 Series CKA are pre-charged with R410A Refrigerant.

CKA

CKA Part numbers	
56517002	CKA35
56517003	CKA50
56517004	CKA70

The older series of CKA's have a nitrogen charge

CKA Part numbers	
56500002	CKA35
56500003	CKA50
56500004	CKA70

NOTE: Please check this before installation.

CKA INSTALLATION

MOUNTING

Whether floor or wall mounted, it is essential that the mounting surface is capable of supporting the unit weight. Leave space around the unit for air circulation and access for installation and maintenance.

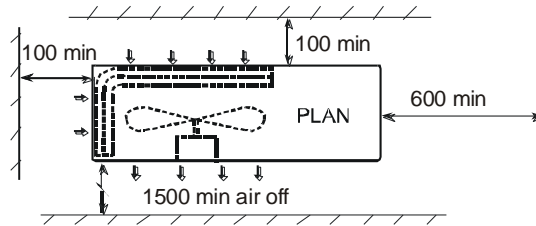

CKA PIPEWORK

NOTE: Please check this before installation.

MAXIMUM EQUIVALENT PIPE LENGTHS 25m

- Performance is based on 15m pipe runs. Allow a 3.5% reduction in capacity for pipe runs above 15m.
- In calculating equivalent lengths of pipe runs, the effect of bends and fittings must be taken into account. The table below covers the fittings most likely to be encountered in this installation.

The equivalent lengths of all the fittings in a pipe run should be added together and the total added to the actual pipe length in order to calculate the total equivalent length.

- Use the shortest possible route, avoiding sharp bends.
- Completely insulate the suction line, fully over the indoor unit drain tray.

FITTING LOSSES, in equivalent straight lengths of pipe (m).

FITTING	Pipe Size OD			To calculate the total equivalent length, the equivalent lengths of all fittings in a pipe run must be added to the actual length of pipe in the run: these are the fittings most likely to be used. R = Radius of bend d = Diameter of tube C = Centres of bend
	3/8"	1/2"	5/8"	
45° Bend	0.12	0.15	0.18	
90° Bend R/d = 1	0.37	0.43	0.49	
90° Bend R/d = 1.5	0.24	0.27	0.30	
180° Bend R/d = 1.5	0.73	0.91	1.10	
180° Bend C/d = 2.5	0.46	0.55	0.64	
90° Elbow	0.67	0.85	1.04	

A. SUCTION AND LIQUID/EXPANSION LINES:

The expansion capillary is located in the outdoor unit and the equivalent pipe run is 25m maximum, including a maximum lift of 7.5m. Fully insulate the suction and liquid/expansion line. Ensure the suction pipe is insulated well over the drain tray at the indoor unit. Liquid lines should be routed to avoid hot areas. This prevents flash gas forming, which may result in erratic control of liquid refrigerant to the evaporator.

SYSTEM	MAXIMUM EQUIVALENT LENGTH OF SUCTION LINE PIPE SIZES (m)		LIQUID/EXPANSION LINE		TOTAL CHARGE (kgs) for 7.5m supplied in 17 series units only
	1/2"	5/8"	1/4"	3/8"	
CX(E)A30 + CKA 35	25	-	25	-	0.856
CX(E)A50 + CKA 35	25	-	25	-	0.856
CX(E)A50 + CKA 50	25	-	25	-	1.306
CX(E)A70 + CKA 70	-	25	-	25	1.882

For systems with interconnecting pipework in excess of 7.5 metre add 20gms per metre on CKA 35 & CKA 50, add 30gms per metre on CKA 70. No additional oil is required.

PIPE CONNECTIONS

Units are supplied with the following male flare connections (sizes in inches):

INTERCONNECTING PIPEWORK (Max 25 metres)						
System	Liquid/ Expansion	Suction	Torque (NM)		Nut A/F (mm)	
			Liquid Line	Suction Line	Liquid Line	Suction Line
CX(E)A 30 + CKA35	1/4"	1/2"	17	54	17	24
CX(E)A 50 + CKA35	1/4"	1/2"	17	54	17	24
CX(E)A 50 + CKA50	1/4"	1/2"	17	54	17	24
CX(E)A 70 + CKA70	3/8"	5/8"	34	73	22	27

INTERCONNECTING PIPEWORK

- The Indoor unit has a low pressure charge of N₂, which may be safely released into the atmosphere before connection. The service valves on the outdoor unit should remain closed (IN, fully clockwise) until pipework has been fitted, and system evacuated.
- Connecting the pipework
 - Remove the flare nuts from the suction and liquid service valves.
 - Ensure that the suction line is fully insulated: if an expansion line is used this should also be fully insulated.
 - Place the flare nuts over the incoming pipework and flare the pipe ends. The use of a little refrigeration oil on the flaring tool will help.
 - Connect the pipework between the units. Do not leave pipe ends, valves etc. open to the atmosphere.
R410A is very hygroscopic, and will absorb damaging levels of moisture if left open. Always use two spanners when tightening the flare nuts to avoid twisting the pipes. Use a small amount of refrigerant oil on the mating surfaces.
 - Sight glasses and filter driers are not necessary, but if required should be fitted between the outdoor unit liquid shut off valve and the expansion device.

CKA REFRIGERANT

EVACUATING (DO NOT RELEASE THE OUTDOOR UNIT SERVICE VALVES) UNTIL THE SYTEM IS EVACUATED.

- Release the nitrogen holding charge in the indoor unit to atmosphere. Connect a vacuum pump to the service ports on the outdoor unit valves and evacuate the system to 1000 microns (1 Torr) or better and allow to be held for a minimum of 15 minutes.
- Replace the caps on the service ports, (torque to 25NM).

ADDING REFRIGERANT

- A 3-minute delay occurs between successive compressor operations.
- R410A should be introduced through the Schrader valve on the indoor unit, or the service port on the suction service valve on the outdoor unit. **No other refrigerant must be used.**

NOTE: LABEL R410A POE (supplied loose) TO BE FIXED ABOVE SERVICE VALVES.

- Run the system for a few minutes to allow it to stabilize. Where possible, charge to a sweat line on the evaporator. Typical suction pressure on short lines at UK conditions should be approx. **6.2bar (90 psig)**

CONDENSATE DRAIN

Push fit connections are widely available for the 7/8" (22mm) OD condensate drain and 3/4"(19mm) ID drain stub adaptor. Alternatively 7/8" (22mm) bore plastic tubing may be fitted directly to the stub/adaptor with a hose clamp. Take care not to over tighten hose clamps as this could damage the stub pipe.

ELECTRICAL CONNECTIONS

- Cables are routed to the terminal block via the cable cord grips at the rear of the unit and then through the back of the electrics box (see page 2).
- Cables **MUST** be size compatible with the recommended system fuse.

FUSES

SYSTEM	COOL ONLY		WITH ELECTRIC HEATER	
	1PH	3PH	1PH	3PH
CX(E)A30 + CKA35	16A	-	16A	-
CX(E)A50 + CKA35	20A	-	20A	-
CX(E)A50 + CKA50	20A	-	20A	-
CX(E)A70 + CKA70	20A	-	32A	-

ELECTRICAL DATA

Indoor CX(E)A	30	50	50	70
Outdoor CKA	35	35	50	70
Rated Current Cooling	5.2A	5.2A	8.0A	11.0A
Maximum Running Current	7.3A	7.3A	10.8A	14.2A
Starting Current	26.0A	26.0A	40.0A	61.0A

ELECTRICAL DATA.

UNIT ELECTRICAL LOADS [230V 50Hz 1Ph (A) or 400V 50Hz 3Ph (A/Ph)]

MODEL	FAN MOTOR	HEATER
CX(E)A 30	0.8	13.0
CX(E)A 50	0.8	13.0
CX(E)A 70	0.8	13.0

INTERCONNECTING INSTRUCTIONS FOR CX(E)A AND CKA SYSTEMS

INTERCONNECTING WIRING

2 CORE + EARTH 1.5mm

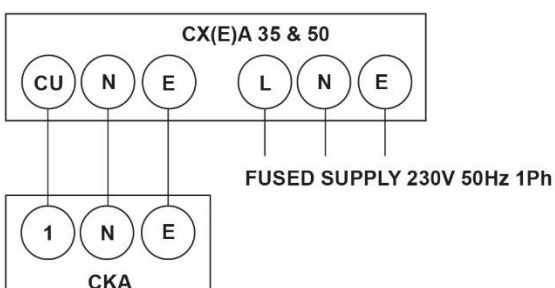

3 CORE + EARTH 1.5mm

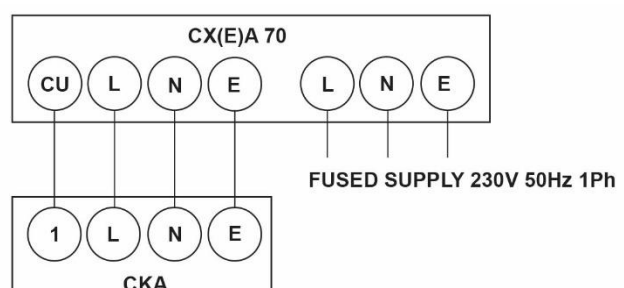

CX(E)A OPTIONS

OPTIONAL KITS	
PART NUMBER	DESCRIPTION
55900700	3kW heater (CXA only)
55900701	Digital temperature display (CXA only) STD on CX(E)A
55900702	De-ice thermostat (CXA only) STD on CX(E)A
55900715	3kW heater (CX(E)A only)

DIMENSIONS & WEIGHTS

MODEL	UNPACKED (all in mm)			
CX(E)A	HEIGHT	WIDTH	DEPTH	WEIGHT
30	483	845	320	18
50	483	845	320	20
70	483	845	320	23

PACKED (all in mm)			
HEIGHT	WIDTH	DEPTH	WEIGHT
530	950	370	21
530	950	370	23
530	950	370	26

CKA	HEIGHT	WIDTH	DEPTH	WEIGHT
				1Ph
35	552	760	256	35
50	552	760	256	42
70	660	860	307	56

HEIGHT	WIDTH	DEPTH	WEIGHT
			1Ph
620	863	376	38
620	863	376	46
730	990	415	63

PERFORMANCE DATA (kW)

MODEL	RATING CONDITIONS (ROOM 12.7°C / 10°C) (AMBIENT 27°C / 19°C)		OPTIONAL ELECTRIC HEATER	
	TOTAL	SENSIBLE	240V	230V
	CX(E)A 30 + CKA 35	2.28	1.98	3.25
CX(E)A 50 + CKA 35	3.25	2.48	3.25	3.0
CX(E)A 50 + CKA 50	4.25	2.90	3.25	3.0
CX(E)A 70 + CKA 70	5.60	3.83	3.25	3.0

MODEL	RATING CONDITIONS (ROOM 12.7°C / 10°C) (AMBIENT 35°C / 19°C)		OPTIONAL ELECTRIC HEATER	
	TOTAL	SENSIBLE	240V	230V
	CX(E)A 30 + CKA 35	2.20	1.77	3.25
CX(E)A 50 + CKA 35	2.83	2.15	3.25	3.0
CX(E)A 50 + CKA 50	3.50	2.45	3.25	3.0
CX(E)A 70 + CKA 70	4.62	3.24	3.25	3.0

Allow a 3.5% reduction in capacity for pipe runs above 15m.

AIRFLOWS

MODEL	m³/s
CX(E)A 30	0.61
CX(E)A 50	0.66
CX(E)A 70	0.58

MODEL	m³/s
CKA 35	0.81
CKA 50	0.78
CKA 70	0.70

SOUND POWER AND SOUND PRESSURE LEVELS

INDOOR UNIT

MAXIMUM SPEED	SOUND PRESSURE LEVELS
	dB(A)
CX(E)A 30	39.0
CX(E)A 50	40.5
CX(E)A 70	39.9

Sound Pressure Levels in dB(A) at 10m distance in free field conditions. (Reference $2 \times 10^{-5} \text{ N/m}^2$)

OUTDOOR UNIT

MAXIMUM SPEED	SOUND PRESSURE LEVELS
	dB(A)
CKA 35	41.5
CKA 50	44.5
CKA 70	44.5

Sound Pressure Levels in dB(A) at 10m distance in free field conditions. (Reference $2 \times 10^{-5} \text{ N/m}^2$)

CXE(A) ELECTRONIC COOLING SYSTEM CONTROLS

Parameters

Code	Function	Set Range	Default Value	Note
F1	Temperature Set Value	-50.0 - 99.9°C	10.0°C	Factory Set to 12.0°C
F2	Difference Set Value	0.3 – 10.0°C	0.5°C	Factory Set to 1.0°C
F3	Compressor Delay Time	1 – 10 Minutes	3 Minutes	
F4	Temperature Calibration Value	-10.0 – 10.0°C	0°C	

PLEASE NOTE: On site only parameter F1 (Temperature Set Point) should be changed to suit site conditions. The other parameters should not be changed.

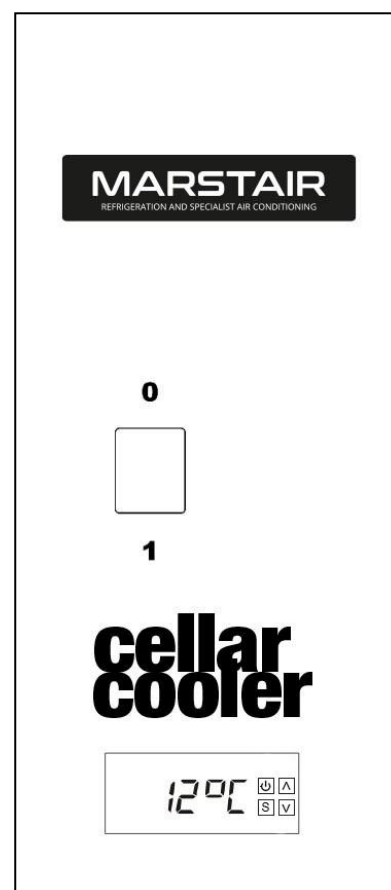

Changing Parameters

To change parameter values do the following:

To scroll through parameters, Press the 'S' key for 3s or more to enter parameter modifying mode. The set indicator light will illuminate, the screen will display the first menu code 'F1'.

Press and hold both the 'S' key and '▲' or '▼' to adjust values as required.

To save the parameter quickly press and release the '⏻' key to instantly save the modified parameter value and return to display the normal temperature value on the controller.

Please Note: After modifying parameter values if no keys are pressed within 10 seconds then the controller won't save the modified parameter and the screen will return to display temperature.