

**MARSTAIR**  
REFRIGERATION AND SPECIALIST AIR CONDITIONING

## INSTALLATION & TECHNICAL MANUAL

**LT**  
**SERIES**



**MARSTAIR REFRIGERATION UNITS MRC+**  
**LT SERIES**  
**LOW TEMPERATURE RANGE**

## INDEX

<b><u>CONTENTS</u></b>	<b><u>PAGE</u></b>
DIMENSIONS & WEIGHTS (packed & unpacked) & SPECIFICATION.	3
PERFORMANCE DATA.	4-5
MOUNTING, DIMENSIONS & WEIGHTS.	6
PIPEWORK.	7
ELECTRICAL & FUSES.	8-10
REFRIGERANT.	11-12
HP / LP SWITCH SETTINGS	14
END OF LIFE REQUIRMENTS.	14
ECO DESIGN INFORMATION TABLES.	15-17
COMPONENT IDENTIFICATION MRC.	18

### **NOTE**

IF MECHANICAL PUMP DOWN OPERATION IS REQUIRED CONNECT A LINK WIRE BETWEEN TERMINALS L1 & 3.  
**IF THIS LINK IS USED THEN TERMINAL 5 CAN NOT BE USED AS AN ALARM FACILITY**

## GENERAL

1. TEV Ltd recommend that personnel working on this equipment be skilled and fully conversant with the appropriate Refrigeration and Electrical practices and have sound knowledge of current Industrial Safe Working practices.
2. These units are supplied with a holding charge of oxygen free nitrogen and polyolester oil. Do not mix oils or refrigerants.
3. These units when installed contain live electrical components, moving parts and refrigerant under pressure. Always site out of reach of children and protect from vandalism.
4. The data plate only gives information for the outdoor unit. For system details add input power and current of indoor and outdoor unit, including any heater load.
5. FUSES - for recommended fuse size see page 8.
6. The refrigerant used should be identified by locating a refrigerant label on the unit case

## DIMENSIONS AND WEIGHTS

### UNPACKED

#### MRC+LT CONDENSING UNITS

MODEL	40	50	60	80	90	100
HEIGHT	620	720	720	820	820	820
WIDTH	1000	1000	1000	1000	1000	1000
DEPTH	300	350	350	425	425	425
1 Ph kg	55	68	69	--	--	--
3 Ph kg	--	66	67	68	78	80

### PACKED

#### MRC+LT CONDENSING UNITS

MODEL	40	50	60	80	90	100
HEIGHT	620	720	720	820	820	820
WIDTH	1090	1090	1090	1090	1090	1090
DEPTH	320	390	390	425	425	425
1 Ph kg	57	70	71	--	--	--
3 Ph kg	--	68	69	70	80	82

## SPECIFICATION DETAILS

MRC+LT		40	50	60	80	90	100
Nominal cooling capacity (-30°C evaporating temp & 32°C ambient temp) R404A	kW 1Ph	1.18	1.66	2.28	-	-	-
	3Ph	-	1.66	2.28	3.00	4.05	4.75
Operating weight kg	1Ph	55	68	69	-	-	-
	3Ph	-	66	67	68	78	80
<b>1 Ph (230V 50Hz) compressor load only</b>							
Power (nominal)	kW	1.1	1.6	2.1	-	-	-
Starting current LRA	A	55	68	81	-	-	-
Current FLA	A	6.5	7.2	11.5	-	-	-
<b>3Ph (400v 50Hz) compressor load only</b>							
Power (nominal)	kW	-	1.5	1.9	2.8	3.4	3.9
Starting current LRA	A	-	24	30	46	64	74
Nominal current FLA	A	-	3.9	5.1	8	11	13.5
<b>Sound Pressure Levels (SPL) at 10m distance in free field conditions @ 27°C external ambient.</b>							
Fan speed max	dBA	35	35	35	37	40	41
	NR	29	29	29	30	33	34
<b>Condenser fan (1Ph 230V 50Hz)</b>							
Airflow (max speed)	m <sup>3</sup> /s	0.4	0.97	0.97	0.97	0.97	0.97
Fan motor rating	kW	0.65	0.13	0.13	0.13	0.13	0.13
Nominal current FLA	A	0.4	0.6	0.6	0.6	0.6	0.6
Fans: No. x diameter	#x mm	1X350	1x457	1x457	1x457	1x457	1X457
Fans max speed	r.p.m	940	940	940	940	940	940

# PERFORMANCE DATA

## MRC+LT 40 – 100 CAPACITIES – 1 & 3 Phase (Return gas temperature 20°C, 0°K sub cooling)

**R407A**

MODEL	Ambient Temp °C	HP	EVAPORATING TEMPERATURE °C									
			-40		-35		-30		-25		-20	
			CAP.	POWER	CAP.	POWER	CAP.	POWER	CAP.	POWER	CAP.	POWER
MRC+ LT 40	27	1 1/2	0.56	0.71	0.81	0.75	1.13	0.86	1.51	0.93	1.96	1.09
	32		0.49	0.69	0.74	0.77	1.00	0.89	1.42	0.98	1.87	1.09
	40		0.39	0.66	0.59	0.80	0.83	0.92	1.20	1.01	1.67	1.15
MRC+ LT 50	27	2	0.77	0.85	1.13	1.02	1.54	1.20	2.08	1.34	2.64	1.60
	32		0.61	0.84	1.05	1.03	1.41	1.25	1.98	1.43	2.58	1.62
	40		0.45	0.79	0.72	1.04	1.11	1.26	1.60	1.48	2.17	1.72
MRC+ LT 60	27	2 1/2	1.04	0.62	1.54	1.32	2.11	1.55	2.83	1.74	3.65	2.08
	32		0.85	1.11	1.37	1.36	1.94	1.60	2.69	1.84	3.47	2.11
	40		0.63	1.06	1.01	1.35	1.51	1.61	2.21	1.88	3.04	2.19
MRC+ LT 80	27	4	1.75	1.70	2.20	1.75	2.76	1.80	3.40	1.90	4.10	2.00
	32		1.60	1.95	2.10	2.00	2.55	2.05	3.20	2.10	3.90	2.20
	40		1.36	2.30	1.75	2.35	2.20	2.40	2.75	2.45	3.40	2.55
MRC+ LT 90	27	5	2.36	2.32	2.97	2.45	3.64	2.71	4.44	2.83	5.29	3.19
	32		2.16	2.60	2.83	2.75	3.44	2.98	4.25	3.18	5.09	3.47
	40		1.84	3.07	2.36	3.40	2.97	3.53	3.59	3.86	4.35	4.18
MRC+ LT 100	27	6	2.70	2.77	3.41	3.00	4.21	3.20	4.80	3.30	6.06	3.69
	32		2.39	3.24	3.26	3.40	4.04	3.53	4.96	3.80	5.94	4.05
	40		1.90	4.23	2.95	4.30	3.33	4.52	4.09	4.75	5.04	5.07

## MRC+LT 40 – 100 CAPACITIES – 1 & 3 Phase (Return gas temperature 20°C, 0°K sub cooling)

**R407F**

MODEL	Ambient Temp °C	HP	EVAPORATING TEMPERATURE °C									
			-40		-35		-30		-25		-20	
			CAP.	POWER	CAP.	POWER	CAP.	POWER	CAP.	POWER	CAP.	POWER
MRC+ LT 40	27	1 1/2	0.58	0.75	0.84	0.79	1.17	0.94	1.57	0.98	2.08	1.15
	32		0.51	0.71	0.76	0.80	1.05	0.93	1.46	1.03	1.96	1.15
	40		0.41	0.70	0.62	0.84	0.88	0.98	1.27	1.06	1.76	1.19
MRC+ LT 50	27	2	0.80	0.91	1.18	1.09	1.60	1.31	2.17	1.41	2.81	1.68
	32		0.64	0.87	1.08	1.08	1.48	1.32	2.04	1.51	2.70	1.70
	40		0.47	0.83	0.76	1.10	1.17	1.35	1.69	1.57	2.29	1.79
MRC+ LT 60	27	2 1/2	1.07	1.09	1.61	1.40	2.20	1.69	2.95	1.84	3.88	2.19
	32		0.89	1.15	1.40	1.40	2.04	1.69	2.77	1.93	3.63	2.21
	40		0.66	1.12	1.06	1.41	1.60	1.72	2.33	1.96	3.20	2.29
MRC+ LT 80	27	4	1.81	1.80	2.30	1.85	2.87	1.95	3.55	2.00	4.36	2.10
	32		1.68	2.00	2.14	2.05	2.68	2.15	3.30	2.20	4.08	2.30
	40		1.43	2.40	1.84	2.45	2.33	2.55	2.90	2.55	3.58	2.65
MRC+ LT 90	27	5	2.39	2.40	3.05	2.60	3.78	3.00	4.71	3.20	5.74	3.45
	32		2.22	2.75	2.90	2.90	3.60	3.30	4.43	3.60	5.39	3.90
	40		1.99	3.40	2.60	3.60	3.23	3.95	4.00	4.25	4.86	4.60
MRC+ LT 100	27	6	2.83	3.00	3.60	3.15	4.49	3.75	5.52	4.05	6.80	4.25
	32		2.64	3.60	3.44	3.70	4.22	4.20	5.18	4.55	6.28	4.85
	40		2.38	4.30	3.06	4.50	3.84	4.90	4.70	5.25	5.75	5.50

**MRC+-LT 40 – 100 CAPACITIES – 1 & 3 Phase**  
(Return gas temperature 20°C, 0°K sub cooling)

**R404A**

MODEL	Ambient Temp °C	HP	EVAPORATING TEMPERATURE °C									
			-40		-35		-30		-25		-20	
			CAP.	POWER	CAP.	POWER	CAP.	POWER	CAP.	POWER	CAP.	POWER
MRC+ LT 40	27	1 1/2	0.69	0.86	0.97	0.85	1.34	1.06	1.76	1.18	2.27	1.32
	32		0.61	0.81	0.87	0.84	1.18	1.05	1.60	1.18	2.07	1.33
	40		0.50	0.76	0.73	0.84	1.00	1.06	1.38	1.19	1.84	1.35
MRC+ LT 50	27	2	0.94	1.05	1.36	1.27	1.83	1.49	2.43	1.71	3.07	1.95
	32		0.76	1.00	1.23	1.25	1.66	1.49	2.23	1.74	2.85	1.99
	40		0.58	0.92	0.90	1.20	1.33	1.47	1.84	1.75	2.39	2.04
MRC+ LT 60	27	2 1/2	1.27	1.26	1.85	1.63	2.51	1.91	3.30	2.21	4.24	2.53
	32		1.06	1.31	1.61	1.60	2.28	1.90	3.03	2.22	3.83	2.57
	40		0.81	1.23	1.26	1.54	1.81	1.87	2.54	2.21	3.34	2.59
MRC+ LT 80	27	4	2.14	2.04	2.65	2.12	3.28	2.18	3.97	2.37	4.76	2.40
	32		2.00	2.25	2.46	2.32	3.00	2.40	3.61	2.50	4.31	2.65
	40		1.75	2.60	2.18	2.65	2.64	2.75	3.16	2.85	3.74	2.98
MRC+ LT 90	27	5	2.89	2.80	3.58	2.90	4.33	3.30	5.19	3.55	6.14	3.85
	32		2.70	3.00	3.32	3.10	4.05	3.50	4.79	3.80	5.63	4.20
	40		2.36	3.48	2.94	3.70	3.56	4.05	4.12	4.50	4.79	4.90
MRC+ LT 100	27	6	3.30	3.35	4.11	3.55	5.00	3.90	5.60	4.15	7.04	4.45
	32		2.99	3.75	3.95	3.85	4.75	4.15	5.60	4.55	6.56	4.90
	40		2.45	4.80	3.30	4.90	4.00	5.20	4.70	5.55	5.54	5.95

**MRC+-LT 50 – 100 CAPACITIES – 1 & 3 Phase**  
(Return gas temperature 20°C, 0°K sub cooling)

**R448A – R449A**

MODEL	Ambient Temp °C	HP	EVAPORATING TEMPERATURE °C									
			-40		-35		-30		-25		-20	
			CAP.	POWER	CAP.	POWER	CAP.	POWER	CAP.	POWER	CAP.	POWER
MRC+ LT 50	27	2	-	-	1.12	0.97	1.57	1.17	2.10	1.38	2.71	1.59
	32		-	-	0.96	0.94	1.39	1.16	1.89	1.38	2.46	1.61
MRC+ LT 60	27	2 ½	-	-	1.39	1.22	1.99	1.47	2.69	1.80	3.54	2.23
	32		-	-	1.20	1.20	1.75	1.46	2.42	1.74	3.23	2.05
MRC+ LT 80	27	4	1.87	2.08	2.38	2.11	3.03	2.13	3.75	2.29	4.59	2.30
	32		1.76	2.34	2.23	2.36	2.79	2.38	3.46	2.48	4.22	2.62
MRC+ LT 90	27	5	2.53	2.85	3.22	2.87	3.99	3.21	4.90	3.42	5.93	3.70
	32		2.38	3.13	3.01	3.14	3.77	3.48	4.58	3.77	5.51	4.15
MRC+ LT 100	27	6	2.89	3.44	3.70	3.53	4.61	3.80	5.29	4.01	6.79	4.31
	32		2.64	3.94	3.58	3.92	4.42	4.14	5.36	4.52	6.42	4.86

## MOUNTING MRC+LT

These units are designed to stand on a flat surface. If the unit is to be wall mounted the following kits are available.

KIT	MRC+LT 40- 60	MRC+LT 80 - 100
<b>Mounting Bracket</b>	55021100	55021101

Whether floor or wall mounted, it is essential that the mounting surface is capable of supporting the unit weight. Leave space around the unit for air circulation and access for installation and maintenance.

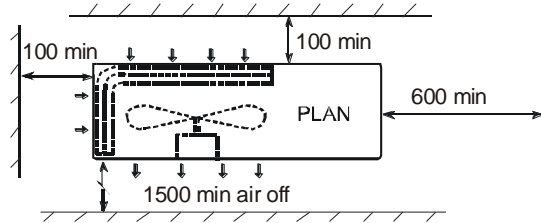

Dimensions in mm.

## DIMENSIONS & WEIGHTS MRC

**MRC+LT 40-100** (Dimensions in mm.)

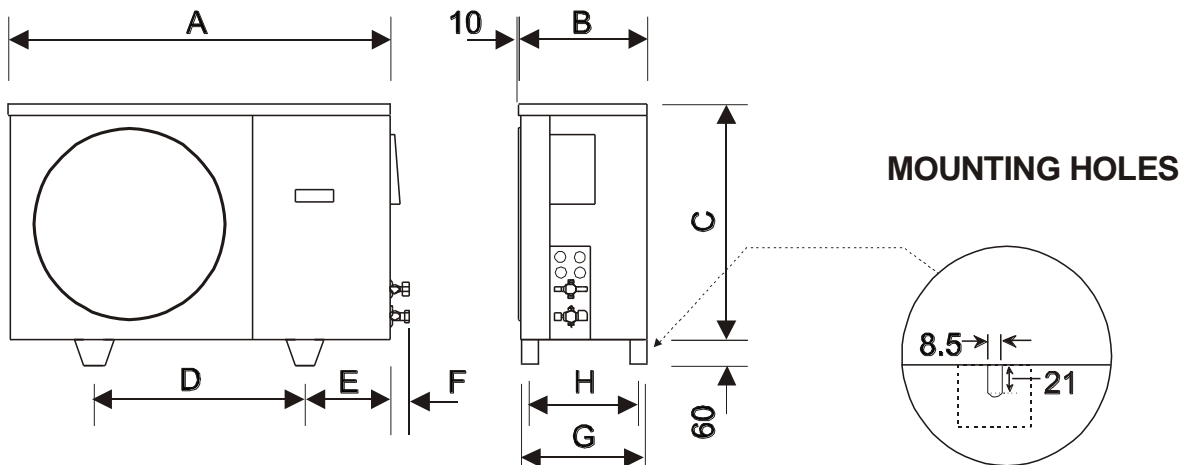

MODEL	A	B	C	D	E	F	G	H	Weight (kg)	
									1 Ph	3 Ph
<b>MRC+LT 40</b>	1000	300	560	525	185	60	275	275	55	-
<b>MRC+LT 50</b>	1000	350	660	495	250	60	345	325	68	66
<b>MRC+LT 60</b>	1000	350	660	495	250	60	345	325	69	67
<b>MRC+LT 80</b>	1000	425	760	495	250	60	417	397	-	68
<b>MRC+LT 90</b>	1000	425	760	495	250	70	417	397	-	78
<b>MRC+LT 100</b>	1000	425	760	495	250	70	417	397	-	80

## PIPEWORK

Supplied male flare connections (sizes in inches)

Model	MRC+LT 40-100					
Size	40	50	60	80	90	100
Liquid	3/8	3/8	3/8	1/2	1/2	1/2
Suction	1/2	1/2	5/8	5/8	5/8	3/4

\* Brazed connections

### MAXIMUM PIPE RUNS

45m maximum including 6m lift. There will be no significant loss of capacity for extended pipe runs provided pipes are correctly sized.

### CALCULATING EQUIVALENT LENGTHS

The effects of bends and fittings must be taken into account.

Pipe sizes are based on:

Minimum of 2.5 m/s (500 fpm) suction gas velocity for horizontal or downflow.

Minimum of 5.0 m/s (1000 fpm) suction gas velocity for upflow.

Maximum of 20.0 m/s (4000 fpm) suction gas.

Where vertical risers exceed 3m, oil traps must be formed in the pipe. This will help ensure that oil returns to the compressor. Typically fit an oil trap every 3m with a trap at the bottom of the riser.

### GOOD PRACTICE

- Keep pipe runs as short as possible.
- Avoid sharp bends
- Fully insulate both suction and liquid including mechanical connections
- Try to avoid running pipes through hot areas.

### PIPE SIZES

UNIT SIZE	MAXIMUM LENGTH OF EQUIVALENT SUCTION LINE PIPE SIZES (m)							LIQUID LINE			
	3/8	1/2	5/8	3/4	7/8	1 1/8	1 3/8	3/8	1/2	5/8	3/4
<b>40</b>		10	36	45				7.5	45		
<b>50</b>		7.5	18	45				7.5	45		
<b>60</b>			14	36	45			7.5	45		
<b>80</b>			11	30	45				45		
<b>90</b>			10	25	45				20	45	
<b>100</b>			7.5	22	45				15	45	

### CONNECTING THE UNITS

1. Connecting the pipework:
  - a. Remove the flare nuts from the service valves and release the nitrogen holding charge by slowly opening the valves using a 5mm or 8mm allen key.
  - b. Ensure the suction line is fully insulated.
  - c. Place the flare nuts over the incoming pipework and flare the pipe ends.
  - d. Connect the pipework between the units. Do not leave pipes ends, valves etc open to the atmosphere. Always use 2 spanners when tightening the flare nuts to avoid twisting the pipes. Use a small amount of refrigerant oil on the mating surfaces.

### EVACUATING

With the valves open, connect a vacuum pump to the service ports on the outdoor unit valves. Evacuate the interconnecting pipework and indoor unit to 1000 microns (1 Torr) or better. Allow this to be held for a minimum of 15 minutes.

## ELECTRICAL

The installer supplies mains, control and interconnecting cables: equipment must be earthed. Wiring must be carried out in accordance with local and national codes. Mains supply cables must be size compatible with the recommended fuse. Cable clamps for use with stranded cables are supplied in units and should be used to secure incoming/outgoing cables. Installers must supply a method of securing solid sheathed cables.

**FUSES:** The system and its supply/interconnecting wiring must be protected by fuses, preferably High Rupture Current (HRC) motor rated types (to BS EN60269) or miniature circuit breakers to (BS EN60898) or local codes having similar time lag characteristics, that allow starting of the compressor yet still afford close overcurrent protection under running conditions. The ratings below are for HRC motor rated fuses.

1PH FUSE SIZE			
MRC+LT	40	50	60
FUSE	16	25	32

3PH FUSE SIZE					
MRC+LT	50	60	80	90	100
FUSE	10	10	16	16	16

The ratings are for the outdoor unit only. Currents for the indoor units including heaters if applicable should be noted and the fuse size increased pro-rata.

### CONNECTION OF MAINS SUPPLY:

1. Ensure the isolator switch is in the **OFF** position.
2. Remove front panel. (3screws)
3. Isolator body is located on the inside of the right hand panel.
4. To remove the isolator body from the external switch slide the red lever downwards.

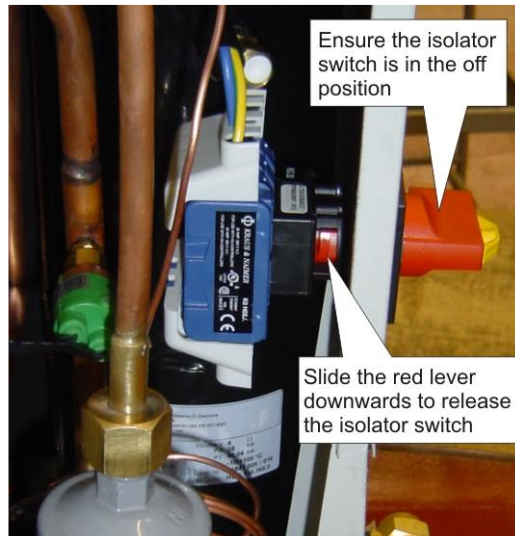

5. Release the main body and lower to the bottom of the unit near the valve panel.
6. Remove lower white plastic cover from the isolator body.
7. Remove knockout hole on the valve panel for your incoming mains supply cable.

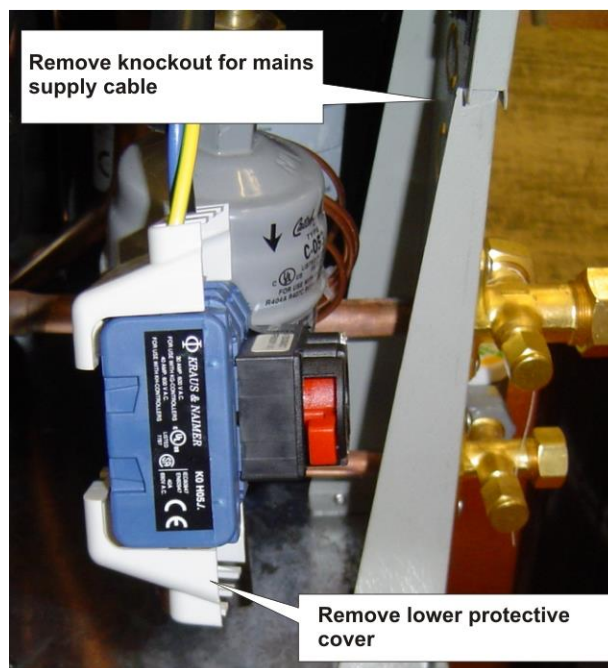

8. Route incoming mains cable through the knockout hole and wire to the required terminals and replace lower protective cover.

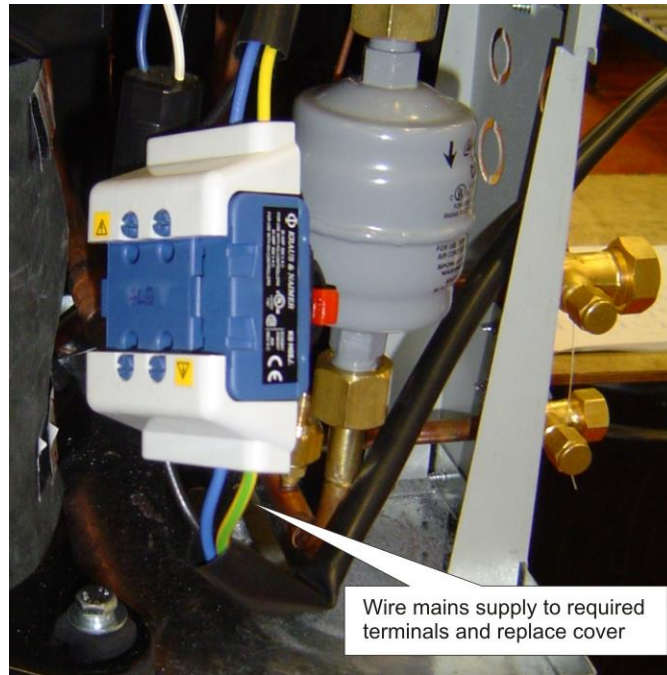

9. Replace main isolator back into the switch and lock into place by sliding the red lever upwards.



Replace covers.

# R404A REFRIGERANT

## Charging the System:

1. Evacuate the system and interconnecting pipework as page 8 ensuring the service valves are fully open.
2. Allow the evacuated system to draw in the majority of the refrigerant charge.
3. The final charge should be adjusted with the system running.
4. All units are fitted with head pressure control. The link wire across the orange terminals allows the fan to operate at full speed. **THIS SHOULD BE REMOVED AFTER CHARGING**
5. A random start delay of up to 1 minute occurs when mains is first applied. A 3 minute delay occurs between successive compressor operations on all systems.
6. Refrigerant and polyolester oil should be introduced through the Schrader valve the service port on the suction service valve on the outdoor unit. **Ensure the refrigerant is the correct type, as shown on the rating plate.** R404A must always be added in the liquid state.
7. Run the system for a few minutes to allow it to stabilize. Where possible, charge to a sweat line on the evaporator. Typical suction pressures on short lines at UK conditions, with high speed evaporator fan, high speed condenser fan, should be; low temperature system approx 4.4 bar (65 psig).
8. **Systems should not be overcharged, to avoid liquid return to the compressor.**
9. **HEAD PRESSURE CONTROL SAGINOMIYA (RGE – ZIN4 – SH)**

The head pressure controller is factory set to suit the refrigerant. It may be necessary to adjust this to suit site conditions, to raise or lower the nominal head pressure.

- a. With the system switched off, connect a high pressure gauge to the liquid line service valve.
- b. Switch on the system, and run for a few minutes to stabilise.

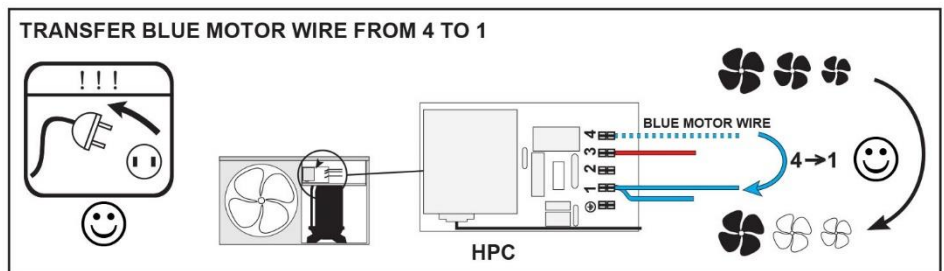

- c. The head pressure should be approximately:

**R404A: 210-220 psig (14.5-15.2 barg)** to achieve this adjust the screw clockwise to increase pressure or anticlockwise to decrease. Each ½ turn will alter the pressure by approx 5 psig (0.5 barg)

Min fan speed (0 rpm) and fan cut in pressure 200 psig (13.8 barg) are factory set and not adjustable.

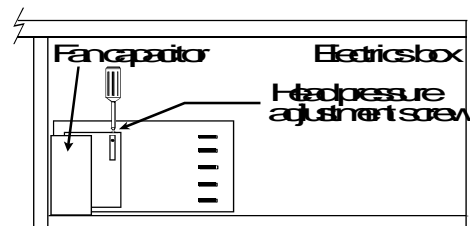

**NOTE:** The condenser fan may stop if the operating pressure drops below 200 psig (13.8 barg)

## 10. HEAD PRESSURE CONTROL ALCO (FSY-42S) & SAGINOMIYA (XGE-4C)

The head pressure controller is factory set to suit the refrigerant. It may be necessary to adjust this to suit site conditions, to raise or lower the nominal head pressure.

### ALCO (FSY-42S)

- a. With the system switched off, connect a high pressure gauge to the liquid line service valve.
- b. Switch on the system, and run for a few minutes to stabilise.
- c. The head pressure should be approximately:

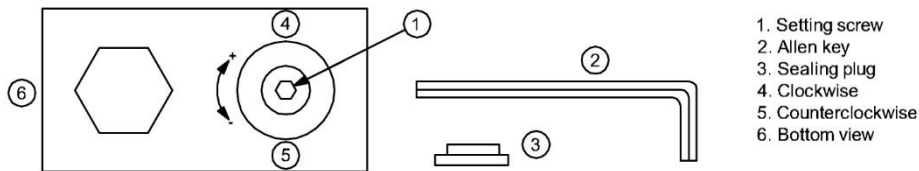

Min fan speed (0 rpm) and fan cut in pressure 200 psig (13.8 barg) are factory set and not adjustable.

**NOTE:** The condenser fan may stop if the operating pressure drops below 200 psig (13.8 barg)

**R404A: 210-220 psig (14.5-15.2barg)** to achieve this remove sealing plug and insert 2mm or 5/64" allen key into setting screw. Turn allen key clockwise (+) or counter clockwise (-) to readjust the setting. Do not turn setting screw **more than 3 turns clockwise (+3)**. Use following table as a quick guideline for setting:

**Pressure changes per turn of adjusting screw:**

Pressure change: 9.2 ... 21.2 bar:  
 Clockwise ~ +2,5 bar, counter clockwise ~ -2,5 bar

After adjustment, re-insert sealing plug and make sure that it is properly fitted. IP65 protection requires firmly sealed plug

**NOTES:**  
 Tolerances for condensing temperatures setpoint:  $\pm 2K$

**SAGINOMIYA (XGE-4C)**

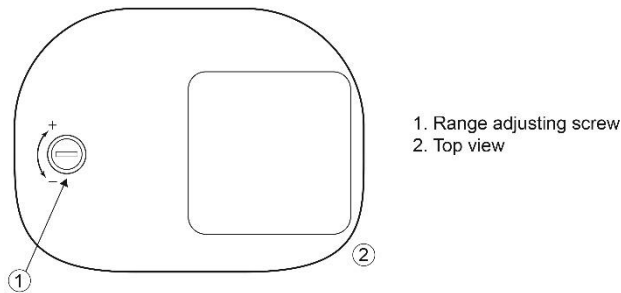

**R404A: 210-220 psig (14.5-15.2barg)** to achieve this turn the range adjusting screw clockwise (+) for increasing the setting value or counter clockwise (-) for decreasing the setting value.

**Pressure changes per 1 turn of adjusting screw:**

Pressure change: 10 ... 25bar:  
 Clockwise ~ +1.5 bar, counter clockwise ~ -1.5 bar

# HP / LP SWITCH SETTING

## High / Low pressure switch



## Settings

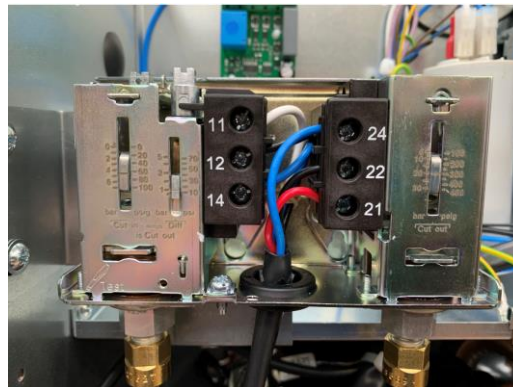
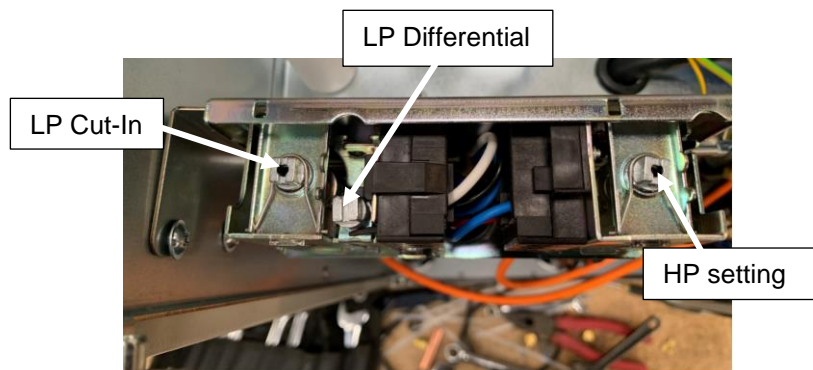

Settings should be made using gauges attached to the suction and discharge service connections. The scale on the switch is for approximation.

### HP cut-out setting

1. Using a flat headed screwdriver, turn the spindle to the desired cut-out setting. For example: To set a Cut-Out pressure of 20 Bar, turn the spindle to the 20 bar (300 psi) mark on the scale.
2. Check the setting using gauges.

### Low Pressure settings

Cut-in minus the Differential = Cut-Out

1. Using a flat headed screwdriver turn the L/H spindle to set the desired cut-in pressure turn the R/H (Diff) spindle to set the desired cut out pressure. For example: To set a cut-in pressure of 2 Bar and a cut-out pressure of 1 Bar
2. Turn the Diff spindle to the 1 Bar (15 psi) mark on the scale. Turn the L/H (Cut-In) spindle to the 2 Bar (30 psi) mark on the scale.
3. Check the settings using gauges.

## END OF LIFE REQUIRMENTS

Refrigerant must be recovered by a certificated technician before the plant is dismantled. Modern refrigerant recovery machines should be able to remove well over 95% of the refrigerant in an old system.

All recovered HFC refrigerants can either be:

- a) Sent for destruction by incineration at a licenced waste facility
- b) Sent to a specialist plant that can re-process the old refrigerant into a gas with properties identical to virgin refrigerant, to create "reclaimed refrigerant"
- c) Given a basic cleaning process, to create "recycled refrigerant"

Given the HFC supply shortage that will be created by the phase down process, it is worth trying to send the old refrigerant for reclamation as it may have a good residual value. If the old refrigerant is too contaminated it cannot be reclaimed and must be sent for destruction. It is important not to mix different gases in the same recovery cylinder – as this would render them unsuitable for reclamation.

Reclaimed refrigerant can be used in any refrigeration equipment. Recycled refrigerant must always be used with care as it may be contaminated or of unknown composition. The use of recycled refrigerant with a GWP above 2,500 is restricted to either (a) the organisation owning the plant from which the gas was recovered or (b) the organisation that carried out the recovery

# ECO DESIGN INFORMATION TABLES

Model(s): MRC+ LT 40 SP			
Refrigerant fluid(s): R404A			
Item	Symbol	Value	Unit
<b>Evaporating temperature</b>	<i>t</i>	-35°C	°C
<b>Parameters at full load and ambient temperature 32°C</b>			
Rated cooling capacity	<i>PA</i>	0.91	kW
Rated power input	<i>DA</i>	0.96	kW
<b>Rated COP</b>	<b><i>COPA</i></b>	<b>0.89</b>	
<b>Parameters at full load and ambient temperature 25°C</b>			
Cooling capacity	<i>P2</i>	1.04	kW
Power input	<i>D2</i>	0.92	kW
<b>Rated COP</b>	<b><i>COP2</i></b>	<b>1.13</b>	
<b>Parameters at full load and ambient temperature 43°C (where applicable)</b>			
Cooling capacity	<i>P3</i>	0.69	kW
Power input	<i>D3</i>	0.91	kW
<b>Rated COP</b>	<b><i>COP3</i></b>	<b>0.76</b>	
<b>Other items</b>			
Capacity control	Fixed		
Contact details	TEV LIMITED Unit 4 Armytage Road Brighouse HD6 1QF		

Model(s): MRC+ LT 50 SP			
Refrigerant fluid(s): R404A			
Item	Symbol	Value	Unit
<b>Evaporating temperature</b>	<i>t</i>	-35°C	°C
<b>Parameters at full load and ambient temperature 32°C</b>			
Rated cooling capacity	<i>PA</i>	1.23	kW
Rated power input	<i>DA</i>	1.25	kW
<b>Rated COP</b>	<b><i>COPA</i></b>	<b>0.98</b>	
<b>Parameters at full load and ambient temperature 25°C</b>			
Cooling capacity	<i>P2</i>	1.45	kW
Power input	<i>D2</i>	1.28	kW
<b>Rated COP</b>	<b><i>COP2</i></b>	<b>1.13</b>	
<b>Parameters at full load and ambient temperature 43°C (where applicable)</b>			
Cooling capacity	<i>P3</i>	0.86	kW
Power input	<i>D3</i>	1.17	kW
<b>Rated COP</b>	<b><i>COP3</i></b>	<b>0.74</b>	
<b>Other items</b>			
Capacity control	Fixed		
Contact details	TEV LIMITED Unit 4 Armytage Road Brighouse HD6 1QF		

Model(s): MRC+ LT 60 SP			
Refrigerant fluid(s): R404A			
Item	Symbol	Value	Unit
<b>Evaporating temperature</b>	<i>t</i>	-35°C	°C
<b>Parameters at full load and ambient temperature 32°C</b>			
Rated cooling capacity	<i>PA</i>	1.61	kW
Rated power input	<i>DA</i>	1.60	kW
<b>Rated COP</b>	<b><i>COPA</i></b>	<b>1.01</b>	
<b>Parameters at full load and ambient temperature 25°C</b>			
Cooling capacity	<i>P2</i>	1.94	kW
Power input	<i>D2</i>	1.64	kW
<b>Rated COP</b>	<b><i>COP2</i></b>	<b>1.18</b>	
<b>Parameters at full load and ambient temperature 43°C (where applicable)</b>			
Cooling capacity	<i>P3</i>	1.20	kW
Power input	<i>D3</i>	1.51	kW
<b>Rated COP</b>	<b><i>COP3</i></b>	<b>0.79</b>	
<b>Other items</b>			
Capacity control	Fixed		
Contact details	TEV LIMITED Unit 4 Armytage Road Brighouse HD6 1QF		

Model(s): MRC+ LT 50 3P			
Refrigerant fluid(s): R404A			
Item	Symbol	Value	Unit
<b>Evaporating temperature</b>	<i>t</i>	-35°C	°C
<b>Parameters at full load and ambient temperature 32°C</b>			
Rated cooling capacity	<i>PA</i>	1.23	kW
Rated power input	<i>DA</i>	1.25	kW
<b>Rated COP</b>	<b><i>COPA</i></b>	<b>0.98</b>	
<b>Parameters at full load and ambient temperature 25°C</b>			
Cooling capacity	<i>P2</i>	1.45	kW
Power input	<i>D2</i>	1.28	kW
<b>Rated COP</b>	<b><i>COP2</i></b>	<b>1.13</b>	
<b>Parameters at full load and ambient temperature 43°C (where applicable)</b>			
Cooling capacity	<i>P3</i>	0.86	kW
Power input	<i>D3</i>	1.17	kW
<b>Rated COP</b>	<b><i>COP3</i></b>	<b>0.74</b>	
<b>Other items</b>			
Capacity control	Fixed		
Contact details	TEV LIMITED Unit 4 Armytage Road Brighouse HD6 1QF		

Model(s): MRC+ LT 60 3P			
Refrigerant fluid(s): R404A			
Item	Symbol	Value	Unit
Evaporating temperature	<i>t</i>	-35°C	°C
<b>Parameters at full load and ambient temperature 32°C</b>			
Rated cooling capacity	<i>PA</i>	1.61	kW
Rated power input	<i>DA</i>	1.60	kW
Rated COP	<i>COPA</i>	1.01	
<b>Parameters at full load and ambient temperature 25°C</b>			
Cooling capacity	<i>P2</i>	1.94	kW
Power input	<i>D2</i>	1.64	kW
Rated COP	<i>COP2</i>	1.18	
<b>Parameters at full load and ambient temperature 43°C (where applicable)</b>			
Cooling capacity	<i>P3</i>	1.20	kW
Power input	<i>D3</i>	1.51	kW
Rated COP	<i>COP3</i>	0.79	
<b>Other items</b>			
Capacity control	Fixed		
Contact details	TEV LIMITED		
	Unit 4		
	Armytage Road		
	Brighouse HD6 1QF		

Model(s): MRC+ LT 80 3P			
Refrigerant fluid(s): R404A			
Item	Symbol	Value	Unit
Evaporating temperature	<i>t</i>	-35°C	°C
Annual electricity consumption	<i>Q</i>	11423	kWh/a
Seasonal energy performance ratio	<i>SEPR</i>	1.61	
<b>Parameters at full load and ambient temperature 32°C (Point A)</b>			
Rated cooling capacity	<i>PA</i>	2.460	kW
Rated power input	<i>DA</i>	2.320	kW
Rated COP	<i>COPA</i>	1.06	
<b>Parameters at part load and ambient temperature 25°C (Point B)</b>			
Declared cooling capacity	<i>PB</i>	2.68	kW
Declared power input	<i>DB</i>	2.07	kW
Rated COP	<i>COPB</i>	1.29	
<b>Parameters at part load and ambient temperature 15°C (Point C)</b>			
Declared cooling capacity	<i>PC</i>	2.95	kW
Declared power input	<i>DC</i>	1.77	kW
Rated COP	<i>COPC</i>	1.67	
<b>Parameters at part load and ambient temperature 5°C (Point D)</b>			
Declared cooling capacity	<i>PD</i>	3.20	kW
Declared power input	<i>DD</i>	1.57	kW
Rated COP	<i>COPD</i>	2.04	
<b>Parameters at full load and ambient temperature 43°C (where applicable)</b>			
Cooling capacity	<i>P3</i>	2.06	kW
Power input	<i>D3</i>	2.80	kW
Declared COP	<i>COP3</i>	0.74	
<b>Other items</b>			
Capacity control	Fixed		
Degradation coefficient for fixed and staged capacity units	<i>Cdc</i>	0.25	
Contact details	TEV LIMITED		
	Unit 4		
	Armytage Road		
	Brighouse HD6 1QF		

Model(s): MRC+ LT 90 3/P			
Refrigerant fluid(s):R404A			
Item	Symbol	Value	Unit
Evaporating temperature	<i>t</i>	-35°C	°C
Annual electricity consumption	<i>Q</i>	14349	kWh/a
Seasonal energy performance ratio	<i>SEPR</i>	1.72	
<b>Parameters at full load and ambient temperature 32°C (Point A)</b>			
Rated cooling capacity	<i>P<sub>A</sub></i>	3.320	kW
Rated power input	<i>D<sub>A</sub></i>	3.100	kW
Rated COP	<i>COP<sub>A</sub></i>	1.07	
<b>Parameters at part load and ambient temperature 25°C (Point B)</b>			
Declared cooling capacity	<i>P<sub>B</sub></i>	3.66	kW
Declared power input	<i>D<sub>B</sub></i>	2.75	kW
Rated COP	<i>COP<sub>B</sub></i>	1.33	
<b>Parameters at part load and ambient temperature 15°C (Point C)</b>			
Declared cooling capacity	<i>P<sub>C</sub></i>	4.12	kW
Declared power input	<i>D<sub>C</sub></i>	2.35	kW
Rated COP	<i>COP<sub>C</sub></i>	1.75	
<b>Parameters at part load and ambient temperature 5°C (Point D)</b>			
Declared cooling capacity	<i>P<sub>D</sub></i>	4.55	kW
Declared power input	<i>D<sub>D</sub></i>	1.95	kW
Rated COP	<i>COP<sub>D</sub></i>	2.33	
<b>Parameters at full load and ambient temperature 43°C (where applicable)</b>			
Cooling capacity	<i>P<sub>3</sub></i>	2.72	kW
Power input	<i>D<sub>3</sub></i>	3.85	kW
Declared COP	<i>COP<sub>3</sub></i>	0.71	
<b>Other items</b>			
Capacity control	Fixed		
Degradation coefficient for fixed and staged capacity units	<i>C<sub>dc</sub></i>	0.25	
Contact details	TEV LIMITED Unit 4 Armytage Road Brighouse HD6 1QF		

Model(s): MRC+ LT 100 3/P			
Refrigerant fluid(s):R404A			
Item	Symbol	Value	Unit
Evaporating temperature	<i>t</i>	-35°C	°C
Annual electricity consumption	<i>Q</i>	18271	kWh/a
Seasonal energy performance ratio	<i>SEPR</i>	1.61	
<b>Parameters at full load and ambient temperature 32°C (Point A)</b>			
Rated cooling capacity	<i>P<sub>A</sub></i>	3.950	kW
Rated power input	<i>D<sub>A</sub></i>	3.850	kW
Rated COP	<i>COP<sub>A</sub></i>	1.03	
<b>Parameters at part load and ambient temperature 25°C (Point B)</b>			
Declared cooling capacity	<i>P<sub>B</sub></i>	4.35	kW
Declared power input	<i>D<sub>B</sub></i>	3.40	kW
Rated COP	<i>COP<sub>B</sub></i>	1.28	
<b>Parameters at part load and ambient temperature 15°C (Point C)</b>			
Declared cooling capacity	<i>P<sub>C</sub></i>	4.86	kW
Declared power input	<i>D<sub>C</sub></i>	2.90	kW
Rated COP	<i>COP<sub>C</sub></i>	1.68	
<b>Parameters at part load and ambient temperature 5°C (Point D)</b>			
Declared cooling capacity	<i>P<sub>D</sub></i>	5.30	kW
Declared power input	<i>D<sub>D</sub></i>	2.55	kW
Rated COP	<i>COP<sub>D</sub></i>	2.08	
<b>Parameters at full load and ambient temperature 43°C (where applicable)</b>			
Cooling capacity	<i>P<sub>3</sub></i>	3.20	kW
Power input	<i>D<sub>3</sub></i>	5.00	kW
Declared COP	<i>COP<sub>3</sub></i>	0.64	
<b>Other items</b>			
Capacity control	Fixed		
Degradation coefficient for fixed and staged capacity units	<i>C<sub>dc</sub></i>	0.25	
Contact details	TEV LIMITED Unit 4 Armytage Road Brighouse HD6 1QF		

# COMPONENT IDENTIFICATION

MRC+LT 40 – 100

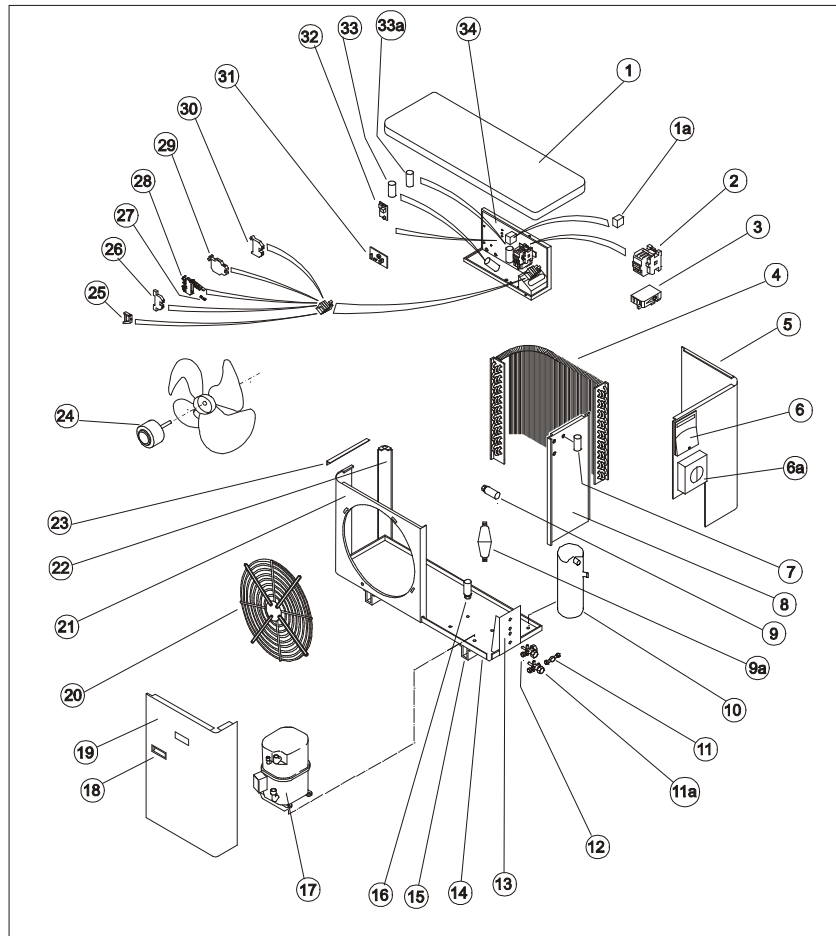

1	LID	11	SIGHT GLASS	23	SUPPORT BRACKET
1a	RELAY (CSR) 1ph only	11a	SERVICE VALVE (LIQUID)	24	FAN / MOTOR ASSEMBLY
2	CONTACTOR	12	SERVICE VALVE (SUCTION)	25	END CLAMP
3	OVERLOAD	13	VALVE PANEL	26	TERMINAL
4	HEAT EXCHANGER COIL	14	BASE	27	FUSE
5	REAR ACCESS PANEL	15	MOUNTING FOOT	28	FUSE TERMINAL
6	MAINS TERMINAL COVER	16	LP SWITCH	29	TERMINAL (4 WAY)
6a	ISOLATOR	17	COMPRESSOR	30	EARTH TERMINAL
7	FAN CAPACITOR	18	HANDLE	31	HEAD PRESSURE CONTROL pcb
8	BULKHEAD PANEL	19	FRONT ACCESS	32	3 MINUTE TIMER pcb
9	HP SWITCH (MANUAL, OPTION)	20	FAN GUARD	33	CAPACITOR (CSR) 1ph only
9a	DRIER	21	FASCIA PANEL	33a	COMPRESSOR CAPACITOR
10	RECEIVER	22	CORNER PANEL	34	ELECTRICS BOX