

CC 600 & CC 875 CO2 EVAPORATOR & LPHW MANUAL



ENGLISH	PAGE NO.
PART NUMBERS	2
FEATURES AND OPTIONS	2
PERFORMANCE FIGURES	3-4
UNPACKING THE UNIT	5
OPTIONAL KITS	5
DIMENSIONS AND WEIGHTS	5
REMOVAL OF CHASSIS	6
REINSTALLING THE CHASSIS	6
INSTALLATION	6
PIPEWORK	6
CONDENSATE DRAIN PIPING	6
FUSE RATINGS	7
INSULATION	7
FAN SPEED SELECTION	8
INTERCONNECTING WIRING	8
SOUND POWER & HYDRALIC RESISTANCE	9
DISCHARGE BLANKING	10
FITTING THE FASCIA	10
CONTROLS	11
WIRING DIAGRAM	13
CHECK-LIST	14

GENERAL

1. TEV Ltd recommend that personnel working on this equipment be skilled and fully conversant with the appropriate Air Conditioning, Refrigeration and Electrical practices and have sound knowledge of current Industrial Safe Working practices.
2. These units are supplied with a holding charge of oxygen free nitrogen.
Do not open the valves until the system is fully installed.
3. These units contain live electrical components, moving parts and refrigerant under pressure.
Always site out of reach of children and protect from vandalism.
4. The data plate only gives information for the indoor unit.
5. Evaporator tested to 120 bar pressure.
6. Max operating pressure 90 bar
7. Appropriate safety devices must be fitted to ensure maximum operating pressure is not exceeded.

PART NUMBERS

MODEL	UNIT	FASCIA	
		AIR CONDITIONING	LOW TEMPERATURE
CC 875 Cool + Heat	55533006	55522000	55533102
CC 600 Cool + Heat	55233008	55222000	55233102
CC 600 Cool Only	55233006	55222000	55233102
CWC(600) 25 LPHW	55233010	55222000	55233102
CWC(600) 45 LPHW	55233011	55222000	55233102
CWC(600) 65 LPHW	55233012	55222000	55233102
CWC(600) 75 LPHW	55233013	55222000	55233102
CWC(875) 95 LPHW	55533010	55522000	55533102
CWC(875) 135 LPHW	55533011	55522000	55533102
CWC(875) 155 LPHW	55533012	55522000	55533102

FEATURES AND OPTIONS

	600	875
DE-ICE THERMOSTAT / SENSOR	STD	STD
3 FAN SPEED COMBINATIONS	STD	STD
REMOTE HARD WIRED CONTROL	STD	STD
0.5M LIFT PUMP (Cooling)	STD	STD
FILTER	STD	STD
ELECTRIC HEATER	*	*
ADJACENT ROOM SPIGOT	*	*
FRESH AIR SPIGOT	*	*
FOAM BLANKING KIT	*	*
(*) = OPTION STD = Fitted as standard		

**PERFORMANCE FIGURES COOLING
CC 600**

FAN SPEED	MODEL	AIR ON °C	HUMIDITY 75% RH	EVAPORATING TEMPERATURE °C											
				-2.5		0		2.5		5		7		7.5	
				Total	Sens	Total	Sens	Total	Sens	Total	Sens	Total	Sens	Total	Sens
LOW	20	5	75	0.86	0.66	0.33	0.33	-	-	-	-	-	-	-	-
		10	75	1.7	1.1	1.3	0.9	0.86	0.66	-	-	-	-	-	-
		15	75	2.7	1.6	2.3	1.4	1.8	1.1	1.4	0.9	0.5	0.5	0.5	0.5
		20	50	3.1	2.1	2.7	1.9	2.2	1.6	1.8	1.4	1.2	1.2	1.2	1.2
		23	50	3.7	2.3	3.3	2.1	2.9	1.9	2.4	1.7	2	1.5	1.8	1.4
MEDIUM	20	5	75	0.94	0.73	0.51	0.51	-	-	-	-	-	-	-	-
		10	75	1.8	1.2	1.4	1	0.94	0.73	-	-	-	-	-	-
		15	75	2.9	1.7	2.5	1.5	2	1.2	1.5	1	1	0.7	0.5	0.5
		20	50	3.4	2.3	3	2.1	2.5	1.8	2	1.6	1.2	1.2	1.2	1.2
		23	50	4.1	2.6	3.7	2.3	3.1	2.1	2.7	1.8	2.2	1.6	2	1.6
HIGH	20	5	75	1	0.8	0.57	0.57	-	-	-	-	-	-	-	-
		10	75	2	1.3	1.6	1.1	1	0.8	-	-	-	-	-	-
		15	75	3.2	1.9	2.8	1.6	2.2	1.3	1.7	1.1	1.2	0.8	1	0.8
		20	50	3.8	2.5	3.3	2.3	2.7	2	2.2	1.7	1.5	1.5	1.5	1.5
		23	50	4.5	2.8	4	2.6	3.4	2.3	2.9	2	2.4	1.8	2.2	1.7

CC 875

FAN SPEED	MODEL	AIR ON °C	HUMIDITY 75% RH	EVAPORATING TEMPERATURE °C											
				-2.5		0		2.5		5		7		7.5	
				Total	Sens	Total	Sens	Total	Sens	Total	Sens	Total	Sens	Total	Sens
MEDIUM	80	5	75	2.1	1.6	1.4	1.4	-	-	-	-	-	-	-	-
		10	75	3.8	2.5	3.1	2.1	2.1	1.6	1.2	-	-	-	-	-
		15	75	6.8	4.0	5.7	3.5	4.4	2.7	3.1	2.0	1.1	1.1	1.1	1.1
		20	50	7.8	5.3	6.7	4.7	5.4	3.9	3.9	3.1	2.6	2.6	2.6	2.6
		23	50	9.4	5.8	8.2	5.2	7.1	4.7	5.3	3.7	4.3	3.3	3.9	3.1
HIGH	80	5	75	2.6	2.0	1.7	1.7	-	-	-	-	-	-	-	-
		10	75	4.4	3.0	3.2	2.3	2.5	2.0	1.4	-	-	-	-	-
		15	75	7.8	4.6	6.5	3.9	5.1	3.1	3.6	2.4	2.4	1.7	1.2	1.2
		20	50	9.2	6.2	7.8	5.5	6.4	4.6	4.8	3.8	2.9	2.9	2.9	2.9
		23	50	11.1	7.0	9.7	6.0	7.9	5.4	6.5	4.3	5.3	3.8	4.8	3.8
BOOST	80	5	75	2.8	2.2	1.9	1.9	-	-	-	-	-	-	-	-
		10	75	5.0	3.2	4.0	2.7	2.8	2.2	1.8	-	-	-	-	-
		15	75	8.6	5.1	7.5	4.3	5.6	3.3	4.1	2.6	2.9	2.0	2.4	2.0
		20	50	10.2	6.7	8.8	6.1	6.9	5.1	5.3	4.1	3.6	3.6	3.6	3.6
		23	50	12.1	7.5	10.7	7.0	8.7	5.9	7.0	4.8	5.8	4.3	5.3	4.1

LPHW HEATING

CC 600

LPHW temperature		Speed				
		Ultra Low	Low	Medium	High	Boost
60	30	1.1	1.17	1.22	1.29	1.36
50	30	0.94	1.00	1.06	1.11	1.18

20°C Return air temperature

CC 875

LPHW temperature		Speed				
		Ultra Low	Low	Medium	High	Boost
60	30	4.42	5.64	6.08	6.77	7.50
50	30	3.24	4.14	4.46	4.97	5.50

20°C Return air temperature

CC 600 LPHW ONLY

LPHW temperature		25	45	65	75
60	30	1.2	2.3	3	4
60	40	3	5	6.5	8
65	40	3.5	5.5	7	8.5
50	30	1	2	2.8	3.5

CC 875 LPHW ONLY

LPHW temperature		95	135	155
60	30	7.5	10.5	13
60	40	11	14	17
65	40	13	17	20
50	30	6.5	9	11

UNPACKING / DÉBALLAGE / GERÄT AUSPACKEN

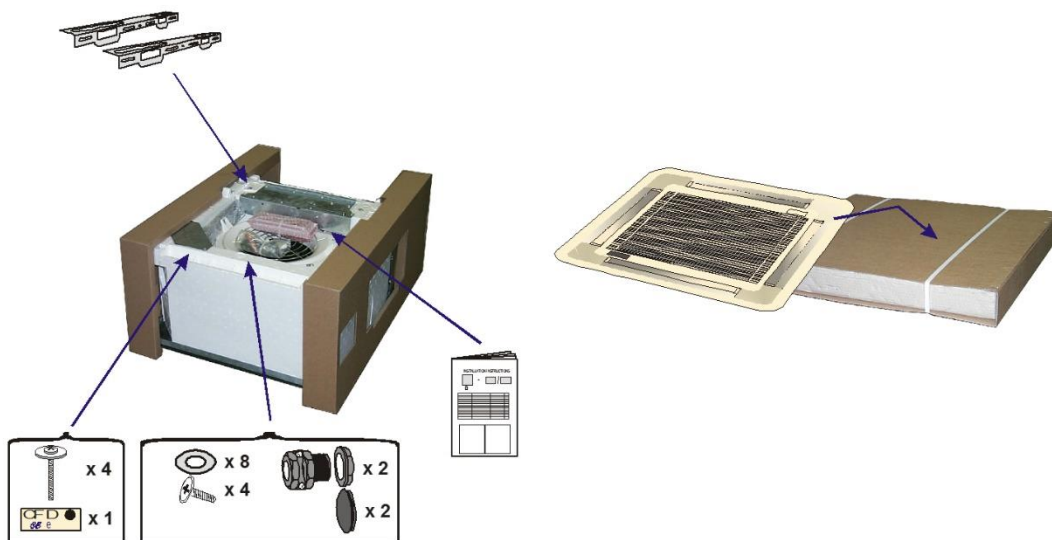

OPTIONS - (Fit any of these kits before installing the unit: some may also be factory fitted)

OPTIONS - (A monter avant d'installer l'unité)

ZUBEHÖR - (Alle Bausätze einbauen bevor das Gerät montiert wird: viele sind auch werkseingebaut lieferbar)

<p>55200306 ADJACENT ROOM SPIGOT PIQUAGE DÉRIVATION NEBENRAUMANSCHLUSS</p> <p>100Ø</p>	<p>55500304 ADJACENT ROOM SPIGOT PIQUAGE DÉRIVATION NEBENRAUMANSCHLUSS</p> <p>150Ø</p>
<p>55200305 FRESH AIR SPIGOT PIQUAGE AIR NEUF FRISCHLUFTANSCHLUSS</p> <p>100Ø</p>	<p>55200305 FRESH AIR SPIGOT PIQUAGE AIR NEUF FRISCHLUFTANSCHLUSS</p> <p>100Ø</p>
<p>55500316 FOAM BLANKING KIT SCHAUMSTOFF ABDECKUNG</p> <p>x 6</p>	<p>55500316 FOAM BLANKING KIT SCHAUMSTOFF ABDECKUNG</p> <p>x 6</p>

DIMENSIONS & WEIGHTS / DIMENSIONS ET POIDS / ABMESSUNGEN & GEWICHTE

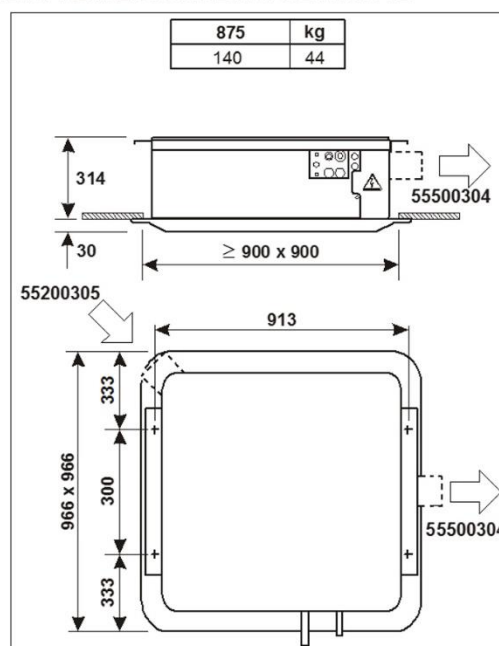
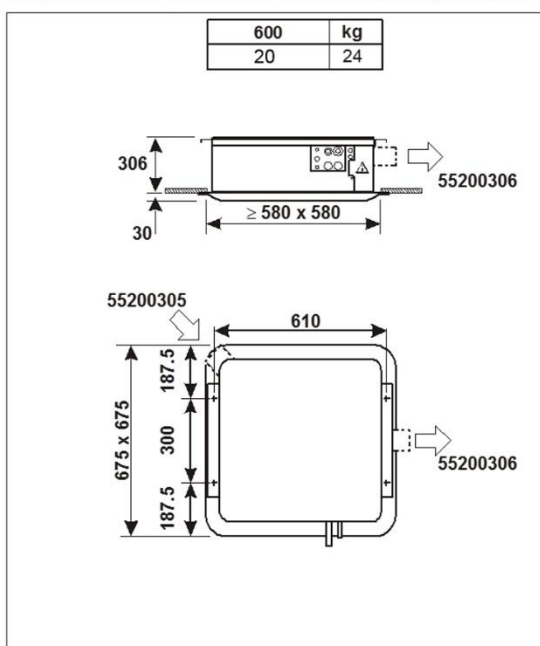

REMOVAL OF CHASSIS / DÉPOSE DU CHASSIS / ABBAU DES GEHÄÜ

FOR EASIER ACCESS (SOLID CEILINGS)
 POUR UN MONTAGE FACILE AU PLAFOND
 FÜR BESSERE ZUGÄNGLICHKEIT (ABGEHÄNGTE DECKEN)

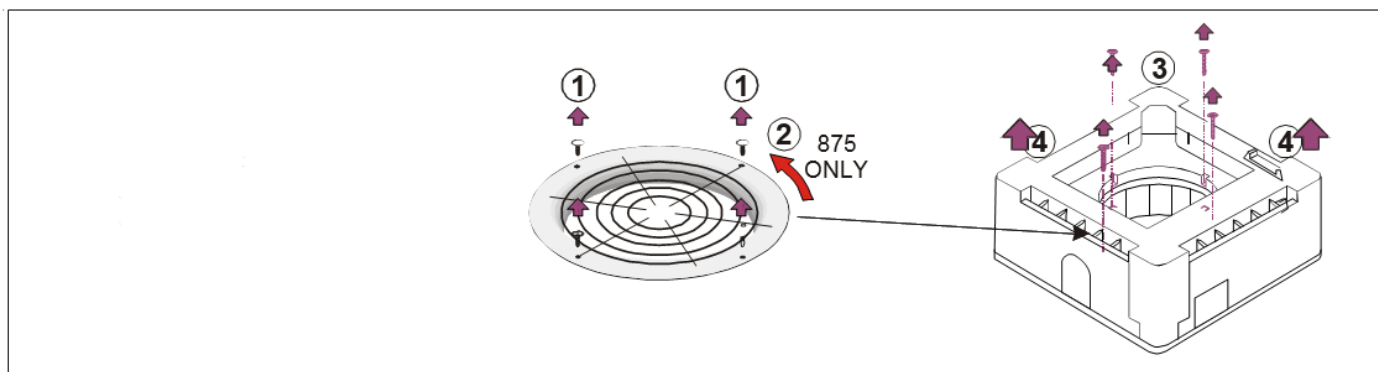

INSTALLATION / INSTALLATION / MONTAGE

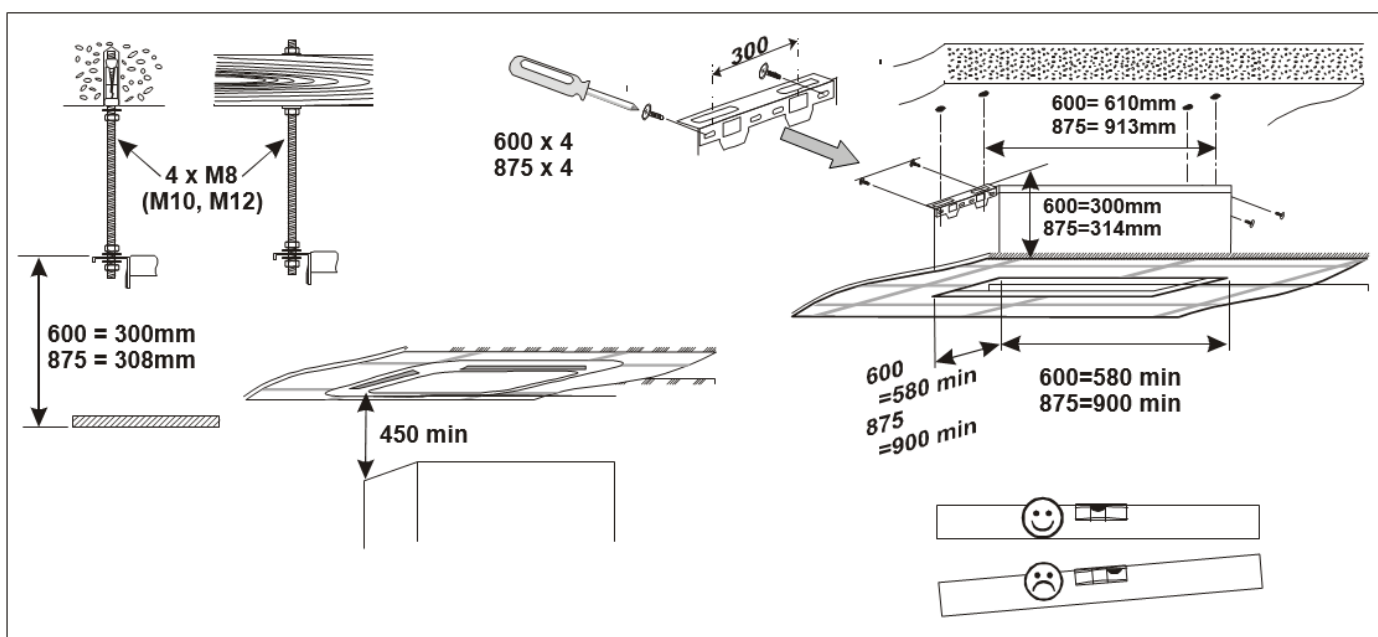

CONDENSATE DRAIN PIPING / EVACUATION CONDENSATS / KONDENSWASSERLEITUN

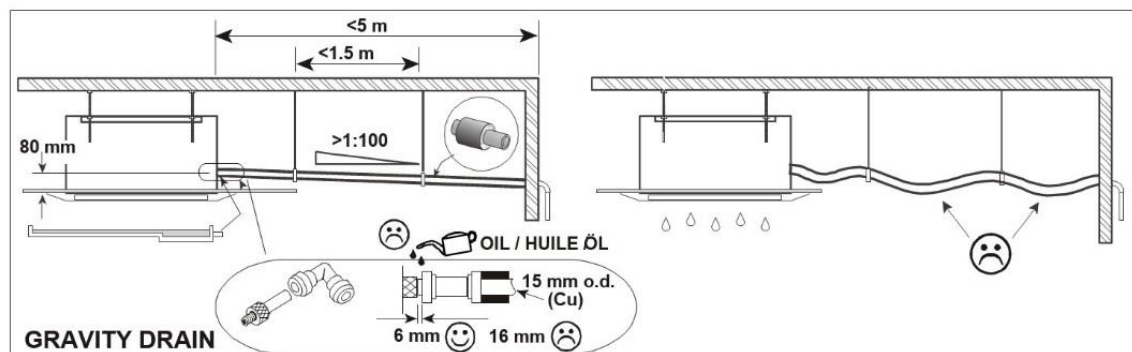

ELECTRICAL DATA – AMPS (230V 50Hz 1Ph)

	600	875
FAN MOTOR	0.5	0.9
LIFT PUMP	9mA	9mA
ELECTRIC HEATER 1kW	4.2	4.2
ELECTRIC HEATER 2kW	8.3	8.3
ELECTRIC HEATER 3kW	X	12.5
ELECTRIC HEATER 4kW	X	8.3 + 8.3

FUSES / DISJONCTEURS / SICHERUNGEN (EN60269) - MCBs (EN60898) (fuses are for indoor unit only with independent supply)

	CC600	CC875
S	13 Amp	13 Amp
H	16 Amp	25 Amp

S = No Electric Heating / Sans Batterie Electrique / Ohne Elektroheizung
H = + Electric Heaters / + Batterie Electrique / Mit Elektroheizung
H1= 0.92kW, H2 = 1.84kW, H3 = 2.76kW,

PIPEWORK CONNECTION / RACCORDMENT DES TUYAUTERIES / ROHRLEITUNGEN

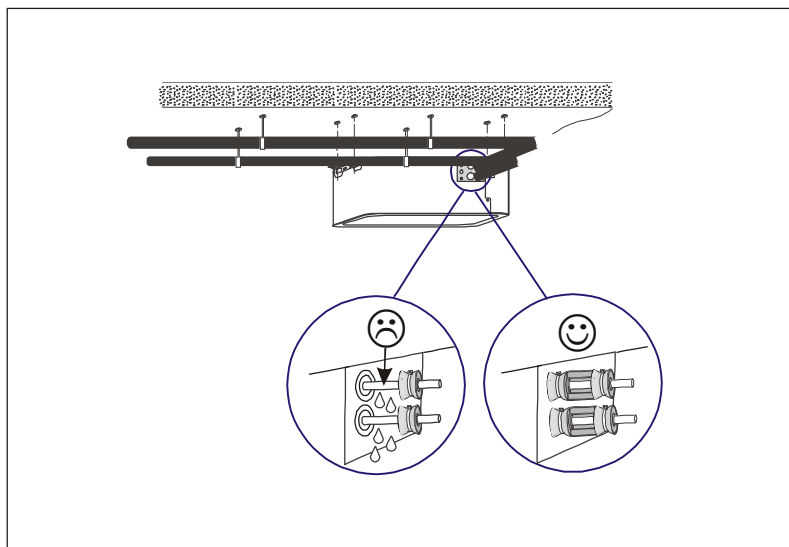

DISCHARGE VELOCITIES

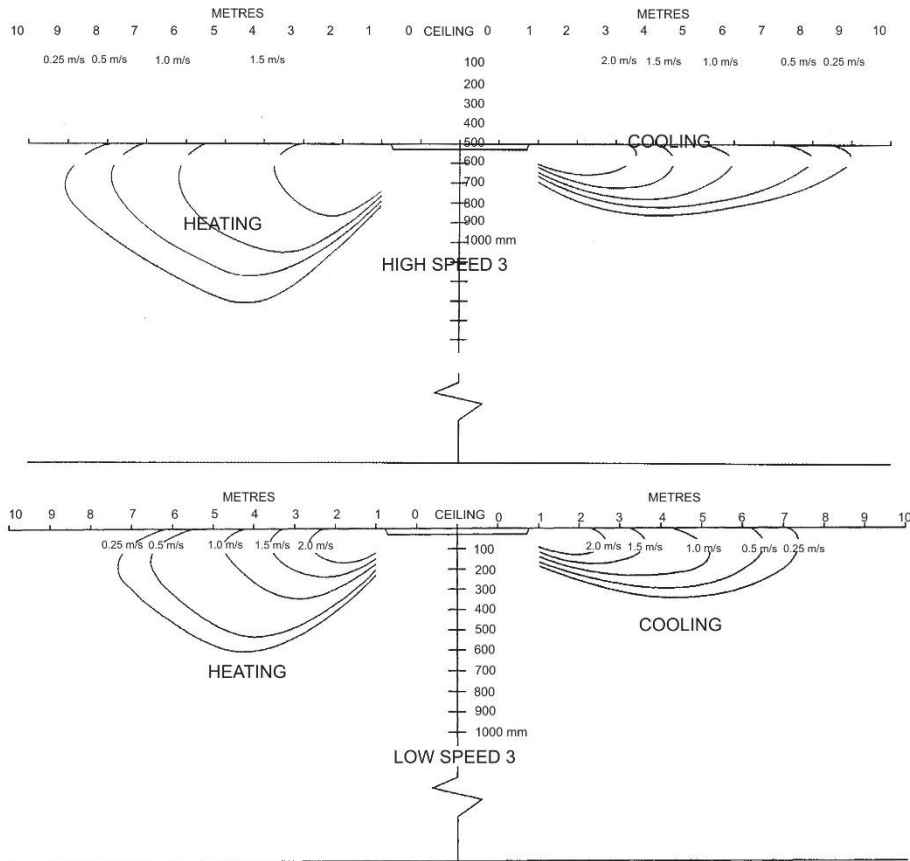

FAN SPEED SELECTION / SÉLECTION DES VITESSES DE VENTILATION / LÜFTERSTUFENAUSWAHL

The fan speed is factory set at medium. (Terminal 3)
To alter the speeds, remove the black link wire from terminal 3 to the required speed terminal.

Terminal	Speed
1	Ultra Low
2	Low
3	Medium
4	High
5	Boost

CC 600

m ³ /s					
CC600 - 20	0.256	0.209	0.173	0.146	0.12

CC 875

m ³ /s				
CC875 - 140	0.50	0.43	0.35	0.30

INTERCONNECTING WIRING / INTERCONNEXIONS / VERBINDUNGSVERDRÄHTUNG

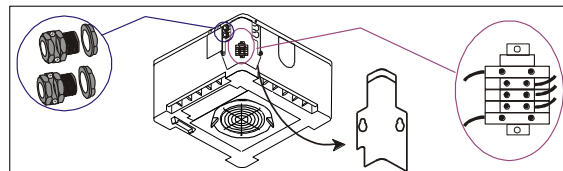
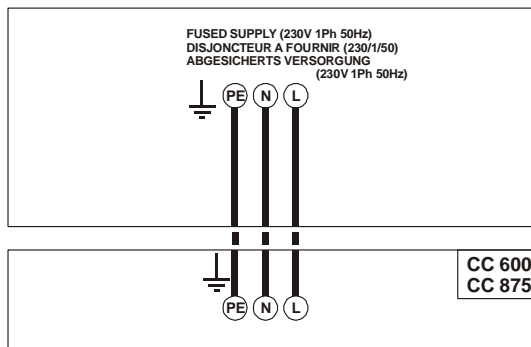

WAGO	Max Ø (mm)	(mm ²)
	3.5	2.5
	4.0	4.0
	5.5	6.0
	6.0	10

CC 600

SPEED	SOUND POWER LEVELS							SOUND PRESSURE LEVELS	
	Frequency Hz							dBA	NC
	125	250	500	1K	2K	4K	dBA		
1	56.3	48.3	45.5	39.0	36.6	35.8	47	26	18
2	58.8	51.9	50.2	44.9	41.4	37.5	52	31	23
3	61.6	57.8	55.6	53.8	48.5	44.4	58	37	31
4	62.9	60.1	57.6	56.3	51.3	46.8	61	40	34
5	67.0	65.6	62.9	61.3	57.6	53.0	66	45	39

CC 875

SPEED	SOUND POWER LEVELS							SOUND PRESSURE LEVELS	
	Frequency Hz							dBA	NC
	125	250	500	1K	2K	4K	dBA		
ULTRA LOW	59.5	55.3	53.4	51.0	37.1	29.9	54.8	37	31
LOW	64.7	60.2	57.5	57.4	47.1	36.9	60	42	38
MEDIUM	67.1	62.3	59.5	59.7	51.7	41.4	63	45	40
HIGH	69.2	64.9	62.2	62.0	56.2	47.1	65	47	43
BOOST	71.5	68.6	66.1	65.2	60.3	54.4	69	51	46

Sound Power Levels were obtained in conformance with ISO 3745. Values are shown in dB with a standard reference of 1 pW.
 Sound Pressure Levels are dB relative to $2 \times 10^{-5} \text{N/m}^2$ and are calculated from results measured in anechoic conditions.
 Values relate to a position of 3m away from the centre line of the unit, 1m down.

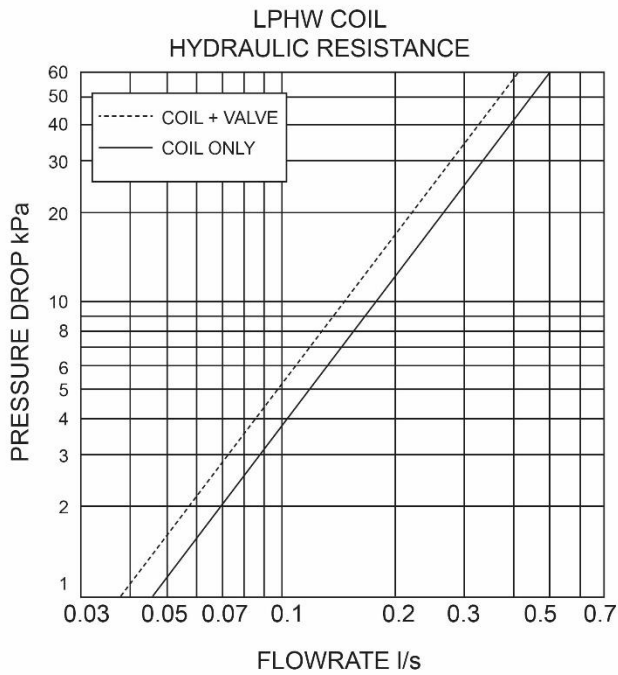

AIR OUTLET BLANKING – KIT 55500316
OBTURATION D'UN CÔTÉ DE SOUFLAGE – KIT 55500316
ABSPERRUNG DES LUFTAUSLASSES – KIT 55500316

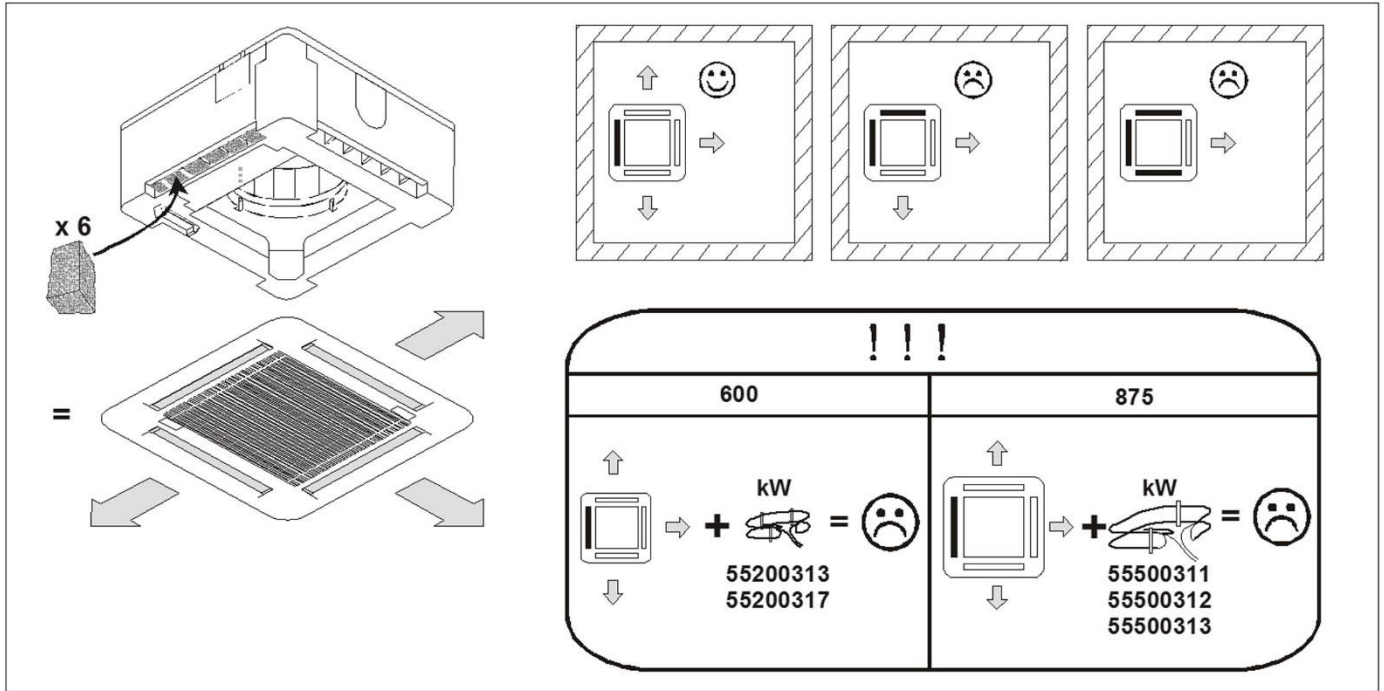

FITTING THE FASCIA / FIXATION DU PLENUM / BLENDMONTAGE

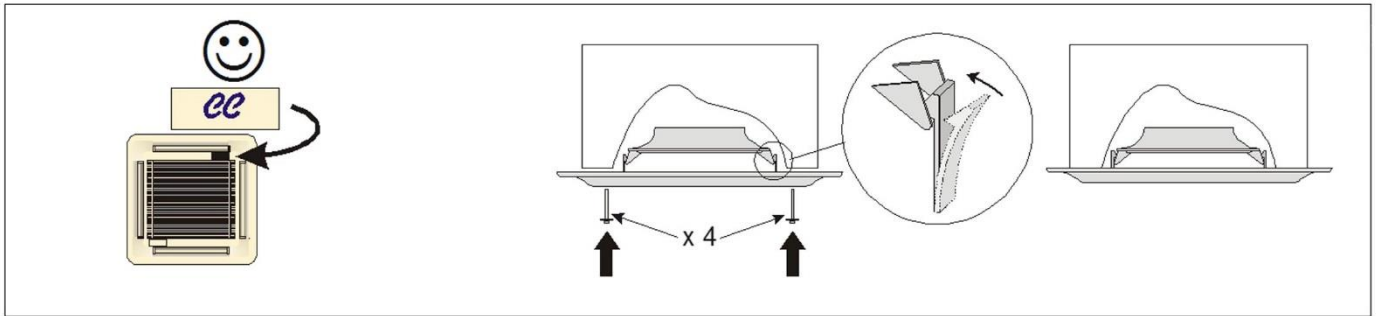

PIPE POSITIONS

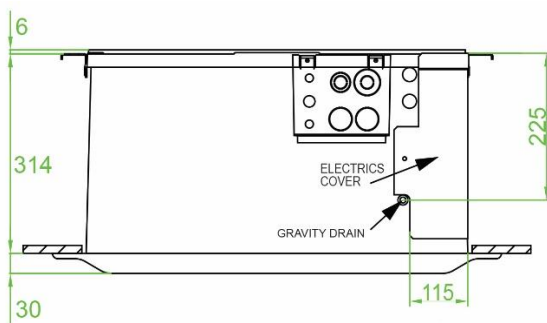

Model	Cooling		Heating	
	In	Out	In	Out
CC 600 Cool Only	7	7	-	-
CC 600 Cool + Heat	7	7	15	15
CC 875 Cool + Heat	12	18	22	22

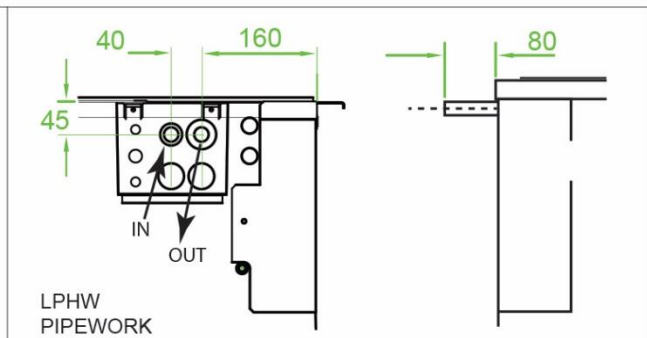
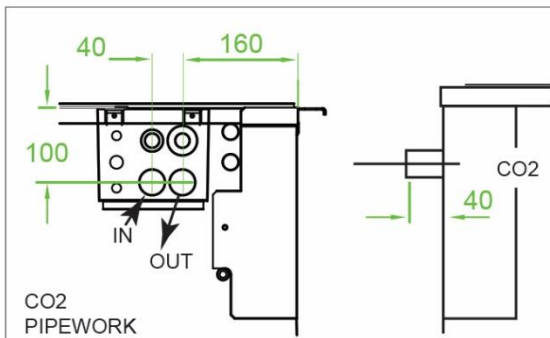

RCC 30 REMOTE CONTROLLER 97200211 - NEW INSTALLATION

The position of the thermostat should account for specific site application:-

- i) Mount on a flat surface within the area conditioned by the unit to which it is connected.
- ii) Avoid draughts, heat from radiators, proximity to hot/cold water pipes, direct sunlight.
- iii) Avoid corners of the room where air is likely to stagnate.
- iv) Avoid direct air discharge from the unit onto the thermostat.
- v) Avoid positions where the thermostat may be covered or obscured.
- vi) If the room contains pillars, mount on the side of the pillar furthest away from the unit.

Using a flat-bladed screwdriver in the slot at the bottom of the casing, lever off the cover.

Mount the backpanel directly to a wall or onto a plinth, using the fasteners supplied.

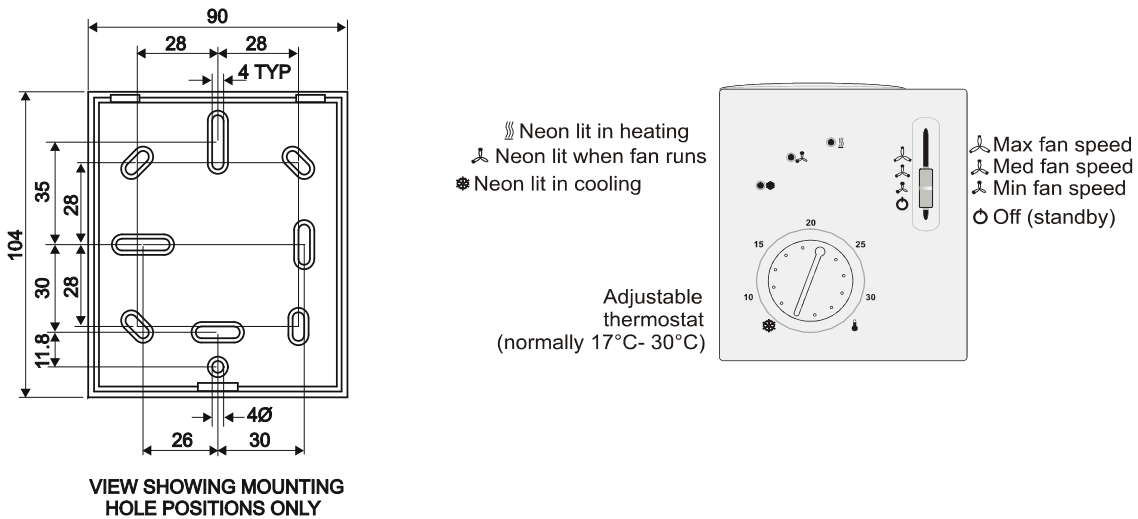

The thermostat should be wired with 7 cores of double insulated cable, 0.5mm² minimum, preferably in plastic conduit for good appearance. Connections are shown on the table on page 2.

The temperature range is factory set to 17°C - 30°C: it is recommended that this is maintained, but if adjustment is needed (eg. to save energy, a range of 21°C - 25°C might be desired) carefully prise off the rotary dial and reset the stops to suit.

Heating is possible only if the system includes a heat pump outdoor unit, or if electric heaters or a Low Pressure Hot Water coil (CW) has been fitted.

RCC 30 optional return air sensor 97200212 can detect return air temperature at the unit rather than the controller. It should be wired between B1 and M on the RCC 30.

The KLRe 52552 return air sensor is not suitable for use with the RCC 30 thermostat: use 97200212 return air sensor.

DIP switches at the bottom rear of the controller are factory set as shown below: these are the recommended settings.

DIP switch	Function	ON position	OFF position
1	Fan control	Fan control is temperature dependent in all operating modes	Fan control in normal operation is temperature independent
2	Operating mode changeover via external switch	Changeover between normal operation and energy saving mode	Changeover between normal operation and standby
3	Action of switch for externally operated mode changeover	Changeover activated when contact of switch is closed	Changeover activated when contact of switch is open
4	Standby	Frost protection disabled	Frost protection enabled
5	Switching differential	1K in heating mode, 0.5K in cooling mode	4K in heating mode, 2K in cooling mode
6	Dead zone in normal operation	2K	5K

= factory settings

OPERATING INSTRUCTION RCC 30 REMOTE CONTROLLER

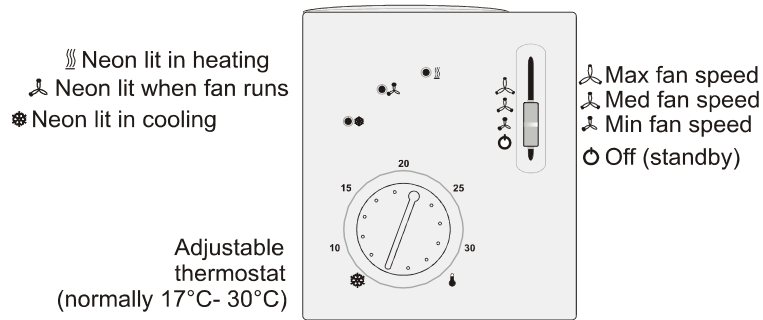

ON / OFF AND FAN SPEEDS

The slider controls the fan speeds as shown above: in its lowest position the unit is in standby ie. the air conditioner has power supplied to it but does not operate.

TEMPERATURE CONTROL

The desired room temperature is set using the rotary switch.

Normally the range is restricted to 17°C - 30°C, although the installer may have set the minimum higher or the maximum lower (eg 20°C - 25°C) to conserve energy.

After resetting the temperature, there may be a short delay (2-3 minutes) before the system operates in its new mode. The air conditioner will then attempt to satisfy the set temperature.

Heating is possible only if the system includes a heat pump outdoor unit or if electric heaters have been fitted (DX systems), or if an LPHW coil is fitted or the unit is supplied from a reverse cycle chiller (CW systems).

For specified low temperature systems : the range is restricted from between 10°C and 16°C.

This adjustment can be made by carefully prising off the rotary dial and re-setting the stops as required.

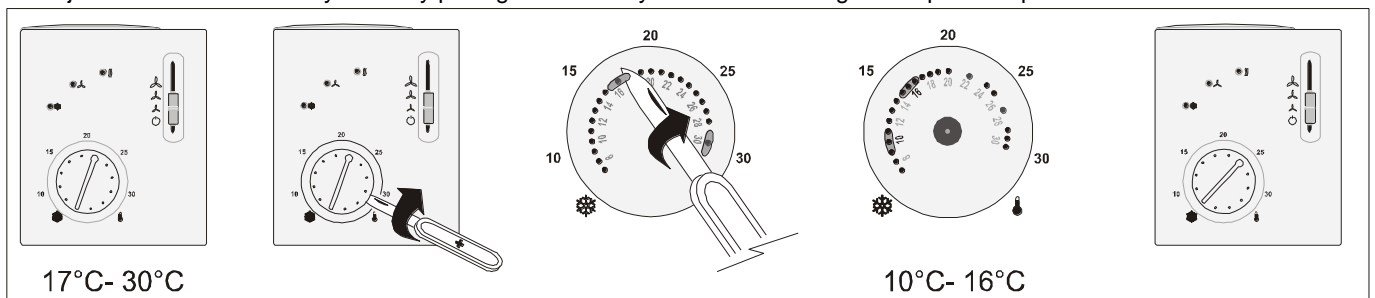

WIRING DIAGRAM

230 VOLT 50HZ
1 PHASE & N
SUPPLY

TO REMOTE CONTROLS (EXTERNAL CONTROLS WIRED BY OTHERS)

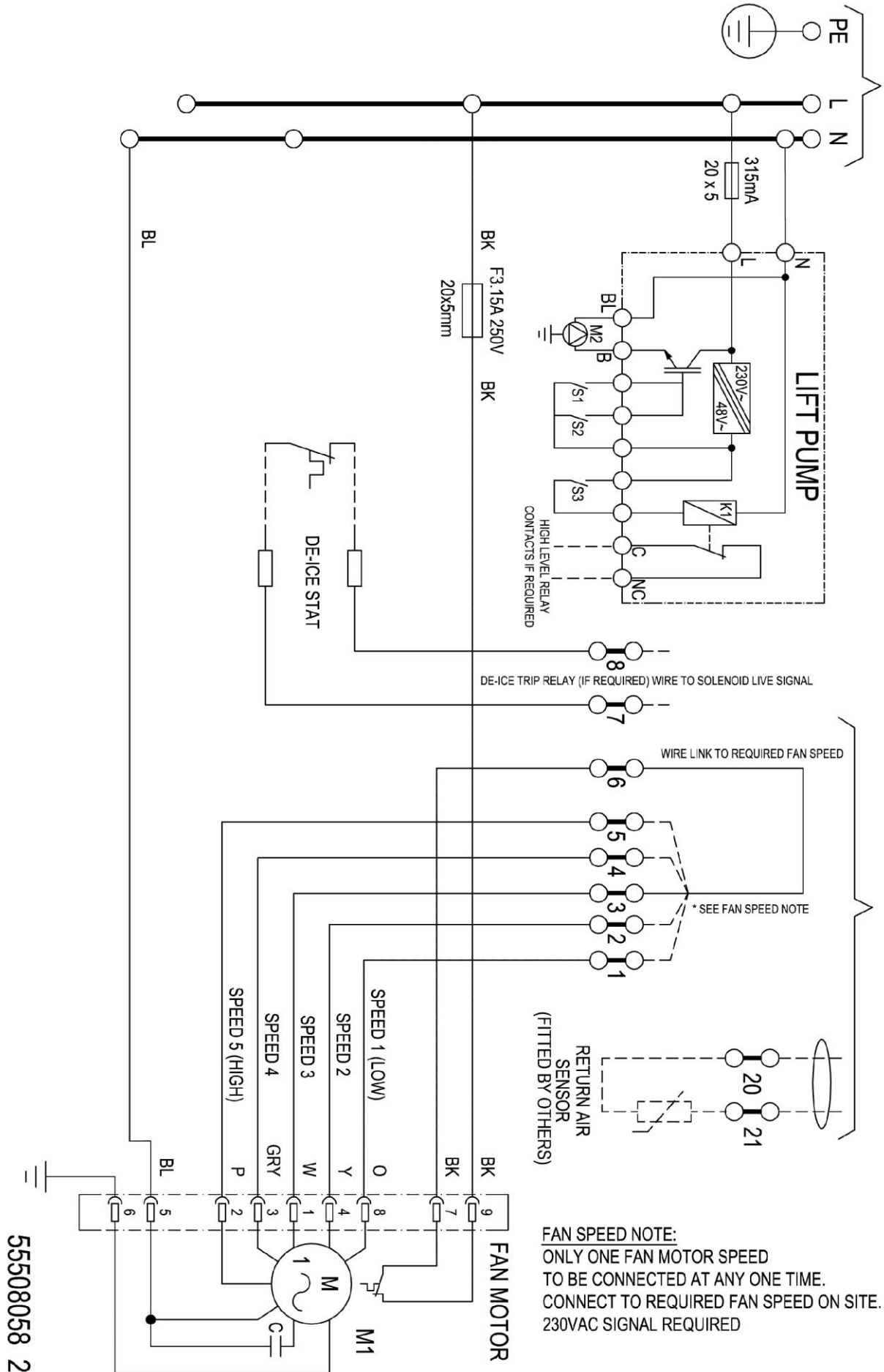

FAN SPEED NOTE:
ONLY ONE FAN MOTOR SPEED
TO BE CONNECTED AT ANY ONE TIME.
CONNECT TO REQUIRED FAN SPEED ON SITE.
230VAC SIGNAL REQUIRED

55508058 2

CC 600 & 875 INSTALLATION CHECK LIST		Page	Checked
1	Is the unit square and level with the ceiling ?	5	
2	Are refrigerant pipes the correct diameters for the pipe run ?	-	
3	Is the pipework correctly supported throughout its length ?	-	
4	Is the expansion and suction pipework insulated right up to the unit ?	6	
5	Have all pipework joints been carefully checked for leaks ?	-	
6	Is the refrigerant charge / oil addition correct ?	-	
7	Is the fuse size correct ?	6	
8	Is the selected fan speed appropriate for the application ?	7	
9	Is the interconnecting wiring correct ?	7	
10	Is the condensate drain correctly sized, connected, supported and insulated ?	5	
11	Has the effectiveness of condensate removal system been tested and there are no leaks ?	5	
12	Is the air distribution as required?	7	
13	Have you fitted kit 55500316 if 3-way air discharge is required ?	9	

CHECK LIST DE L'INSTALLATION DE CC 600 & 875		Page	Vérfié
1	L'unité est-elle fixée de niveau ?	5	
2	Avez-vous passé les bons diamètres de tuyauteries ?	-	
3	Les tuyauteries sont-elles correctement fixées ?	-	
4	Avez-vous isolé les tuyauteries jusqu'au châssis de l'unité ?	6	
5	Avez-vous effectué une recherche de fuites ?	-	
6	La charge de réfrigérant et d'huile est-elle correcte ?	-	
7	La taille du disjoncteur est-elle correcte ?	6	
8	Avez-vous sélectionné les vitesses de ventilation approprié ?	7	
9	Les câblages d'interconnexions sont-ils corrects ?	7	
10	L'évacuation des condensats est-elle correctement raccordée, supportée et isolée ?	5	
11	Avez-vous vérifié le bon fonctionnement de l'évacuation des condensats et qu'il n'y a pas de fuites ?	5	
12	La distribution d'air est-elle correcte ?	7	
13	Désirez vous un soufflage sur 3 côtés ? Kit 55500316	9	

CC 600 & 875 MONTAGE PRÜFLISTE		Seite	Geprüft
1	Ist das Gerät waagrecht und eben eingebaut ?	5	
2	Sind die richtigen Rohrleitungsgrößen verlegt worden ?	-	
3	Sind alle Rohrleitungen über deren gesamte Länge richtig befestigt ?	-	
4	Sind beide Leitungen bis zum Gerätegehäuse isoliert worden ?	6	
5	Sind alle Rohrleitungen und Verbindungen auf Leckagen untersucht worden ?	-	
6	Ist die Kältemittel und Ölfüllung richtig ?	-	
7	Ist die Sicherungsgröße richtig ?	6	
8	Ist die richtige Lüfterdrehzahl eingestellt worden ?	7	
9	Ist die Verbindungsverdrahtung richtig ?	7	
10	Ist die Tauwasserleitung richtig angeschlossen, aufgehängt und isoliert ?	5	
11	Prüfen Sie nach, ob daß Kondenswasser richtig abfließen kann und keine Leckstellen vorhanden sind ?	5	
12	Ist die Luftverteilung wie gewünscht ?	7	
13	3 Wege Ausblas? Bausatz 55500316	9	