

MARSTAIR

REFRIGERATION AND SPECIALIST AIR CONDITIONING

TECHNICAL MANUAL

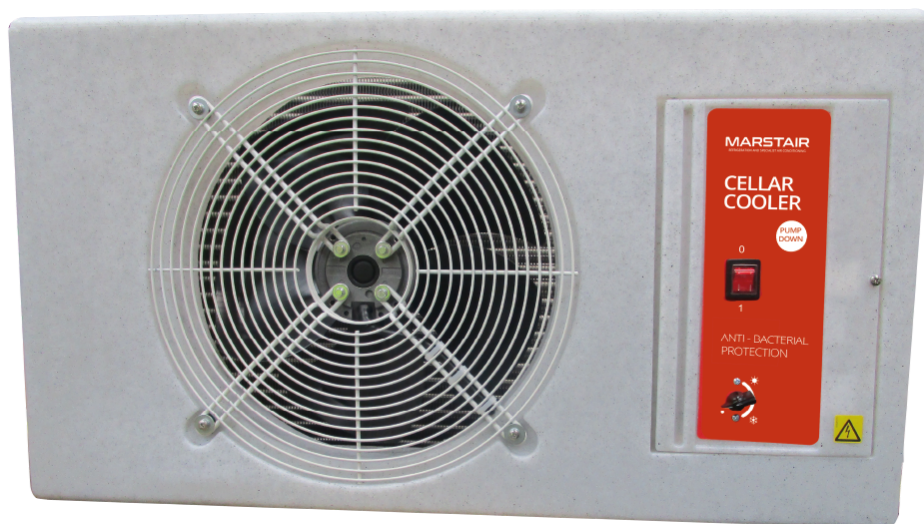

CXE PUMP DOWN SPLIT SYSTEMS

CXE PUMP DOWN LOW TEMPERATURE SPLIT SYSTEMS

INDEX

<u>CONTENTS</u>	<u>PAGE</u>
PART NUMBERS, UNIT COMBINATIONS, OPTIONS	3
DIMENSIONS & WEIGHTS, PERFORMANCE DATA	4
AIR FLOW, SOUND POWER AND SOUND PRESSURE LEVELS	5
ELECTRICAL DATA	6
CX(E) DIMENSIONS	7
INSTALLATION	8
CKC PIPEWORK	8
CKC REFRIGERANT	10
ELECTRICAL: CONNECTIONS & FUSES	12
CX MATCHES	12
WIRING DIAGRAMS	13
CX(E) CONTROLS	15
CKC INSTALLATION: DIMENSIONS	16
COMPONENT IDENTIFICATION	
CX(E) UNITS	17
CKC UNITS	18
COMMISSIONING CHECK LIST	19

GENERAL

1. TEV Ltd recommend that personnel working on this equipment be skilled and fully conversant with the appropriate Air Conditioning, Refrigeration and Electrical practices and have sound knowledge of current Industrial Safe Working practices.
2. CXE models are electromechanical / Electronic control units that use R407C refrigerant; they provide cooling within the range of 2.8 – 8.5 kW. These units are matched with CKC pump down outdoor units to complete a system.
3. CXE Pump Down units are fitted with an expansion assembly and solenoid valve. These units must be ran on a liquid line and matched with the Marstair CKC Pump Down units which are fitted with a liquid receiver.
4. These units contain live electrical components, moving parts and refrigerant under pressure. Always site out of reach of children and protect from vandalism.
5. The data plate only gives information for the CXE unit. For system details add input power and current of indoor and outdoor unit, including any heater load.

PART NUMBERS

MODEL	CXE 30 PD	CXE 40 PD	CXE 50 PD	CXE 70 PD	CXE 90 PD
PART NUMBER	55917006	55917007	55917007	55917009	55917010

MODEL	CKC 20 PD 1ph	CKC 30 PD 1ph	CKC 50 PD 1ph	CKC 80 PD 1ph
PART NUMBER	55050800	55050801	55050803	55050805

Low Temperature Match

MODEL	CXE 40 PD	CXE 50 PD	CXE 70 PD	CXE 90 PD
PART NUMBER	55917007	55917008	55917009	55917010

MODEL	CKC 20 PD 1ph	CKC 40 PD 1ph	CKC 60 PD 1ph	CKC 80 PD 1ph
PART NUMBER	55050800	55050802	55050804	55050805

UNIT COMBINATIONS

Above 8°C System Matches

INDOOR UNIT	OUTDOOR UNIT
CXE 30 PD	CKC 20 PD
CXE 40 PD	CKC 30 PD
CXE 50 PD	CKC 50 PD
CXE 70 PD	CKC 80 PD
CXE 90 PD	CKC 90 PD

Above 4°C System Matches

INDOOR UNIT	OUTDOOR UNIT
CXE 40 PD	CKC 20 PD
CXE 50 PD	CKC 40 PD
CXE 70 PD	CKC 60 PD
CXE 90 PD	CKC 80 PD

CX(E) OPTIONS

OPTIONAL KITS	
PART NUMBER	DESCRIPTION
55900715	3kW heater (CXE only)

* When matched with CKC outdoor unit

DIMENSIONS & WEIGHTS

MODEL	UNPACKED				PACKED				
	CX(E)	HEIGHT	WIDTH	DEPTH	WEIGHT	HEIGHT	WIDTH	DEPTH	WEIGHT
30	483	845	320	18	530	950	370	21	
40	483	845	320	18	530	950	370	21	
50	483	845	320	20	530	950	370	23	
70	483	845	320	23	530	950	370	26	
90	483	845	320	25	530	950	370	28	

MODEL	UNPACKED					PACKED					
	CKC	HEIGHT	WIDTH	DEPTH	WEIGHT		HEIGHT	WIDTH	DEPTH	WEIGHT	
					1Ph	3Ph				1Ph	3Ph
20	620	900	310	46	-	620	980	340	48	-	
30	620	900	310	48	-	620	980	340	55	-	
50	720	1000	350	64	-	730	1090	390	66	-	
60	720	1000	350	64	-	730	1090	390	66	-	
80	720	1000	350	66	64	730	1090	390	68	66	
90	820	1000	350	76	73	820	1090	390	78	75	

PERFORMANCE DATA (kW)

Above 8°C System Matches

CX	CKC	12.7/10 & 27					12.7/10 & 32					12.7/10 & 35				
		Total	Sensible	Cellar Size		SHR	Total	Sensible	Cellar Size		SHR	Total	Sensible	Cellar Size		SHR
				Above	Below				Above	Below				Above	Below	
30	20	2.8	1.88	31	52	0.67	2.7	1.81	29	49	0.67	2.6	1.74	28	47	0.67
40	30	3.6	2.27	44	72	0.63	3.3	2.12	39	64	0.64	3.1	2.02	36	59	0.65
50	50	5.2	3.23	71	114	0.62	5	3.12	67	109	0.62	4.8	3.02	64	104	0.63
70	80	7.2	4.35	108	169	0.60	6.9	4.2	102	161	0.61	6.6	4.05	96	152	0.61
90	90	8.5	5.04	133	206	0.59	8.2	4.85	127	197	0.59	8	4.68	123	192	0.59

CX	CKC	8/6 & 27					8/6 & 32					8/6 & 35				
		Total	Sensible	Cellar Size		SHR	Total	Sensible	Cellar Size		SHR	Total	Sensible	Cellar Size		SHR
				Above	Below				Above	Below				Above	Below	
30	20	2.45	1.6	22	36	0.65	2.3	1.52	20	34	0.66	2.2	1.47	19	33	0.67
40	30	3	1.95	30	51	0.65	2.8	1.83	27	45	0.65	2.6	1.728	25	42	0.66
50	50	4.4	2.78	49	80	0.63	4.2	2.69	47	76	0.64	4	2.6	45	73	0.65
70	80	6.1	3.9	75	118	0.64	5.9	3.75	71	112	0.64	5.7	3.63	67	107	0.64
90	90	7.3	4.55	93	144	0.62	7.1	4.4	89	138	0.62	7	4.31	86	134	0.62

Above 4°C System Matches

CX	CKC	5/3 & 27			5/3 & 32			5/3 & 35		
		Total	Sensible	SHR	Total	Sensible	SHR	Total	Sensible	SHR
40	20	2.1	1.6	0.76	1.9	1.45	0.76	1.8	1.38	0.77
50	40	3.3	2.46	0.75	3.1	2.32	0.75	3	2.25	0.75
70	60	5	3.53	0.71	4.7	3.33	0.71	4.5	3.2	0.71
90	80	5.9	4	0.68	5.7	3.9	0.68	5.5	3.8	0.69

Qualification of Cellar sizing

- Based on standard Cellar Construction
- Maximum product load 16 l/m³
- Product cooling time 24 hours (Nominal plant running time 18 hours)
- Product entering room 25°C

AIR FLOWS

MODEL	m ³ /s
CX(E) 30	0.61
CX(E) 40	0.61
CX(E) 50	0.66
CX(E) 70	0.58
CX(E) 90	0.55

MODEL	m ³ /s
CKC 20	0.32
CKC 30	0.71
CKC40	0.71
CKC 50	0.91
CKC 60	0.91
CKC 80	0.91
CKC90	0.91

SOUND POWER AND SOUND PRESSURE LEVELS

INDOOR UNIT

MAXIMUM SPEED	SOUND POWER LEVELS						SOUND PRESSURE LEVELS
	Frequency Hz						
	125	250	500	1K	2K	4K	dB(A)
CX(E) 30	69.1	67.7	67.6	65.6	62.2	56	39
CX(E) 40	69.1	67.7	67.6	65.6	62.2	56	39
CX(E) 50	71.7	69.2	69.1	67.1	63.2	58.5	40.5
CX(E) 70	70.1	68.2	68.6	66.1	63.2	57.5	39.9
CX(E) 90	70.1	68.2	68.6	66.1	63.2	57.5	39.9

Sound Pressure Levels in dB(A) at 10m distance in free field conditions. (Reference $2 \times 10^{-5} \text{ N/m}^2$)

OUTDOOR UNIT

MAXIMUM SPEED	SOUND POWER LEVELS						SOUND PRESSURE LEVELS
	Frequency Hz						
	125	250	500	1K	2K	4K	dB(A)
CKC 20	77	67	69	65	60	54	39.2
CKC 30	77	68	69	65	60	54	39.3
CKC 40	77	67	69	65	60	54	39.2
CKC 50	74	68	67	66	61	54	38.9
CKC 60	73	68	68	66	62	54	39.3
CKC 80	71	69	68	65	60	54	38.7
CKC90	82	72	69	69	63	57	42.2

Sound Pressure Levels (SPL) at 10m distance in free field conditions. (Reference $2 \times 10^{-5} \text{ N/m}^2$)

ELECTRICAL DATA

Above 8°C System Matches

MODEL INDOOR/OUTDOOR	1 PH 230V 50Hz				
	INPUT POWER		FULL LOADS AMPS		SYSTEM MAX. STARTING CURRENT
	COOLING	HEATING	COOLING	HEATING	
	kW	kW	AMPS	AMPS	AMPS
CX(E) 30 + CKC 20	1.3	2.9	7.7	13.8	30
CX(E) 40 + CKC 30	1.6	2.9	8.2	13.8	38
CX(E) 50 + CKC 50	2.2	2.9	9.7	13.8	60
CX(E) 70 + CKC 80	3.2	2.9	12.3	13.8	78
CX(E) 90 + CKC 90	4.4	2.9	17.7	13.8	116

MODEL INDOOR/OUTDOOR	3 PH 4000V 50Hz				
	INPUT POWER		FULL LOADS AMPS		SYSTEM MAX. STARTING CURRENT
	COOLING	HEATING	COOLING	HEATING	
	kW	kW	AMPS	AMPS	AMPS
CX(E) 70 + CKC 80	3.2	2.9	5.7	13.8	42
CX(E) 90 + CKC 90	4.4	2.9	7.9	13.8	50

Above 4°C System Matches

MODEL INDOOR/OUTDOOR	1 PH 230V 50Hz				
	INPUT POWER		FULL LOADS AMPS		SYSTEM MAX. STARTING CURRENT
	COOLING	HEATING	COOLING	HEATING	
	kW	kW	AMPS	AMPS	AMPS
CXE 40 + CKC 20	1.3	2.9	7.7	13.8	30
CXE 50 + CKC 40	2.1	2.9	10.2	13.8	52
CXE 70 + CKC 60	2.4	2.9	9.8	13.8	63
CXE 90 + CKC 80	3.2	2.9	12.3	13.8	78

UNIT ELECTRICAL LOADS [230V 50Hz 1Ph (A) or 400V 50Hz 3Ph (A/Ph)]

MODEL	FAN MOTOR	HEATER
CX(E) 30	0.8	13
CX(E) 40	0.8	13
CX(E) 50	0.8	13
CX(E) 70	0.8	13
CX(E) 90	0.8	13

CKC	20	30	40	50	60	80	90
Fan motor	0.4	0.6	0.6	0.6	0.6	0.6	0.6
R407C compressor (1 Ph) nominal FLA	6	10.4	10.2	8.3	9.8	10.9	16.3
R407C compressor (3 Ph) nominal FLA	-	-	-	-	-	4.3	6.5
Crankcase heater	0.25	0.25	0.25	-	-	-	-

CX(E) DIMENSIONS

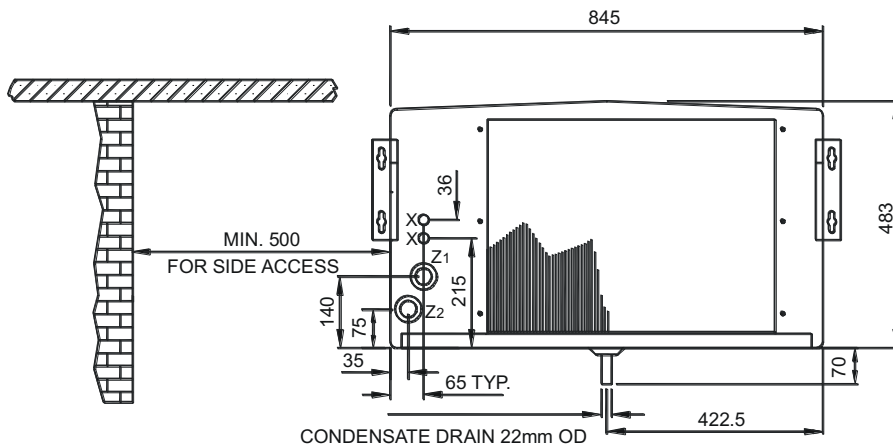
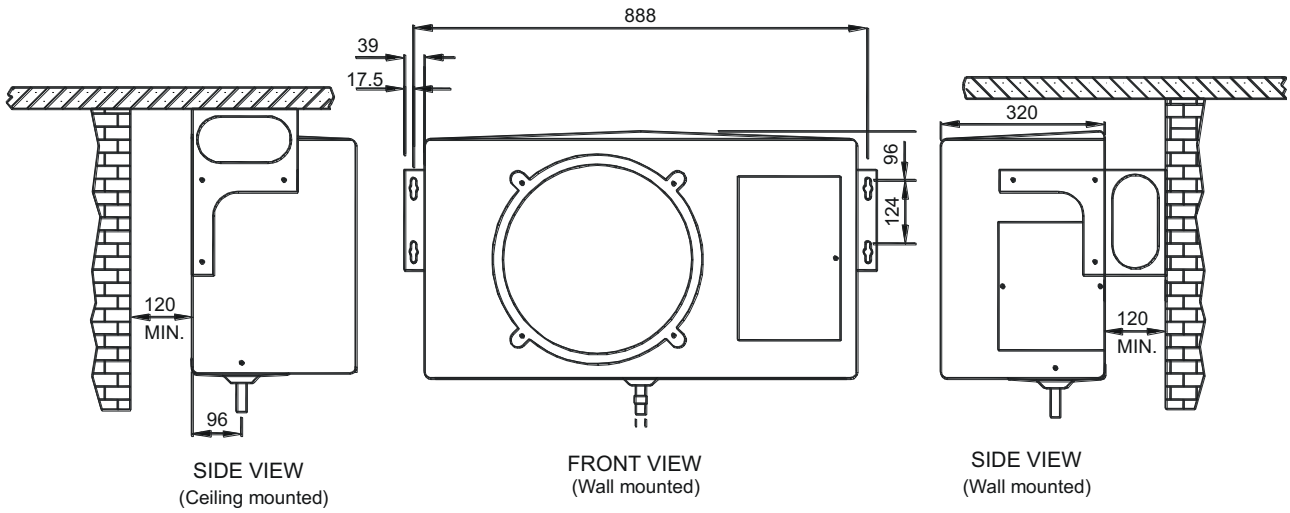
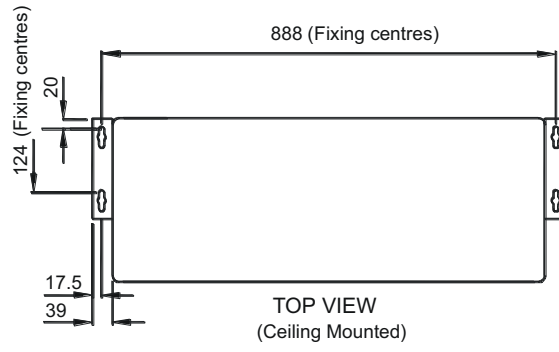

X = Interconnecting Wiring
 Z₁ = Suction
 Z₂ = Liquid / Expansion

REAR VIEW
(Wall mounted)

DIMENSIONS (mm)

INSTALLATION

CONTENTS		
PARTS DESCRIPTION	QTY	ACTION
Envelope containing operating instructions and Declaration of Conformity	1	Pass to the end user.
Mounting brackets	2	Use to hang unit.

Drain Stub/Nut/Gasket	1	Fitted by installer.
Drain stub adaptor	1	Convert to 3/4" drain if required.
Screw M5	6	To fix brackets to unit.
Washer nylon	6	To fix brackets to unit.
Washer M5 shakeproof	6	To fix brackets to unit.
Reducing flare nut 1/2" – 3/8"	1	Fit to liquid connection on the CXE 70 indoor unit when matched with a CKC 60 outdoor unit

The unit may be mounted on a wall or solid ceiling using brackets supplied. It should be matched with the appropriately sized outdoor unit; this instruction should be used in conjunction with the outdoor unit installation instructions.

UNIT COMBINATIONS

Minimum Set Temperature 8°C	
INDOOR UNIT	OUTDOOR UNIT
CX(E) 30	CKC 20
CX(E) 40	CKC 30
CX(E) 50	CKC 50
CX(E) 70	CKC 80
CX(E) 90	CKC 90

Minimum Set Temperature 4°C	
INDOOR UNIT	OUTDOOR UNIT
CXE 40	CKC 20
CXE 50	CKC 40
CXE 70	CKC 60
CXE 90	CKC 80

1. Fit all kits prior to installing the unit. (Heater kit is easier to fit when unit has been mounted).
2. Ensure that the mounting surface will support the operating weight of the unit (see table below).
3. Mark out the mounting positions and drill holes to suit 6mm rawlbolt shields or equivalent strength fasteners (ensure that the unit is positioned to give sufficient access (min 0.5m) to the removable side panel).
4. Fix the mounting brackets to the unit in the correct position for wall or ceiling mounting.
5. Raise the unit into position and secure the fixings, ensuring that it is square and level.
6. Remove the drain tray then fit the drain stub, nut & gasket. Refit the drain tray.

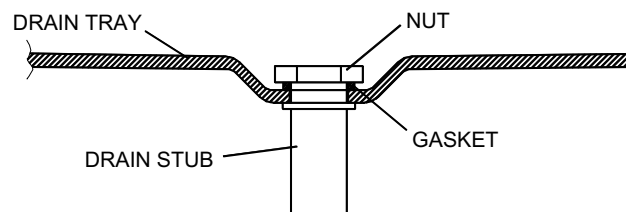

NITROGEN CHARGE

The unit contains a small charge of dry nitrogen, which should be discharged into the atmosphere. This is a non-toxic, non-ozone depleting gas with no global warming potential.

FITTING LOSSES, in equivalent straight lengths of pipe (m).

FITTING	Pipe Size OD					To calculate the total equivalent length, the equivalent lengths of all fittings in a pipe run must be added to the actual length of pipe in the run: these are the fittings most likely to be used. R = Radius of bend d = Diameter of tube C = Centres of bend
	3/8"	1/2"	5/8"	3/4"	7/8"	
45° Bend	0.12	0.15	0.18	0.21	0.24	
90° Bend R/d = 1	0.37	0.43	0.49	0.55	0.61	
90° Bend R/d = 1.5	0.24	0.27	0.3	0.37	0.43	
180° Bend R/d = 1.5	0.73	0.91	1.1	1.28	1.46	
180° Bend C/d = 2.5	0.46	0.55	0.64	0.76	0.85	
90° Elbow	0.67	0.85	1.04	1.25	1.46	

A. USING SUCTION AND LIQUID LINES:

With the expansion device connected to the indoor unit, the equivalent pipe run should be 45m (20m for CKC20) maximum, including a maximum lift of 7.5m. Fully insulate the suction line. Ensure the suction pipe is insulated well over the drain tray at the indoor unit. Liquid lines should be routed to avoid hot areas. This prevents flash gas forming, which may result in erratic control of liquid refrigerant to the evaporator.

SYSTEM	MAXIMUM EQUIVALENT LENGTH OF SUCTION LINE PIPE SIZES (m)					LIQUID LINE (m)			
	3/8"	1/2"	5/8"	3/4"	7/8"	1/4"	3/8"	1/2"	5/8"
CX(E)30 + CKC20	7.5	20	-	-	-	20	-	-	-
CX(E)40 + CKC30	-	15	45	-	-	-	45	-	-
CX(E)50 + CKC50	-	7.5	18	45	-	-	20	45	-
CX(E)70 + CKC80	-	-	11	30	45	-	20	45	-
CX(E)90 + CKC90	-	-	10	25	45	-	-	20	45

SYSTEM	MAXIMUM EQUIVALENT LENGTH OF SUCTION LINE PIPE SIZES (m)					LIQUID LINE		
	3/8"	1/2"	5/8"	3/4"	7/8"	1/4"	3/8"	1/2"
CX(E)40 + CKC20	7.5	20	-	-	-	20	-	-
CX(E)50 + CKC40	-	15	36	45	-	-	20	45
CX(E)70 + CKC60	-	7.5	14	36	45	-	20	45
CX(E)90 + CKC80	-	-	11	30	45	-	20	45

PIPE CONNECTIONS

Units are supplied with the following male flare connections (sizes in inches):

INDOOR UNIT	CX(E)30	CX(E)40	CX(E)50	CX(E)70	CX(E)90
LIQUID / EXPANSION	3/8"	3/8"	3/8"	1/2"	1/2"
SUCTION	1/2"	1/2"	1/2"	5/8"	5/8"

OUTDOOR UNIT	CKC20	CKC30	CKC40	CKC50	CKC60**	CKC80	CKC 90
LIQUID / EXPANSION	3/8"	3/8"	3/8"	3/8"	3/8"	1/2"	1/2"
SUCTION	1/2"	1/2"	1/2"	1/2"	5/8"	5/8"	5/8"

RESTRICTORS

Indoor units are supplied with restrictors fitted.

NOTE

When the CXE 40 is matched with a CKC 20.
The restrictor in the indoor unit must be changed to 0.033"
When the CXE 50 is matched with a CKC 40.
The restrictor in the indoor unit remains as a 0.050"
When the CXE 70 is matched with a CKC 60.
The restrictor in the indoor unit must be changed to 0.057"
When the CXE 90 is matched with a CKC 80.
The restrictor in the indoor unit must be changed to 0.063"

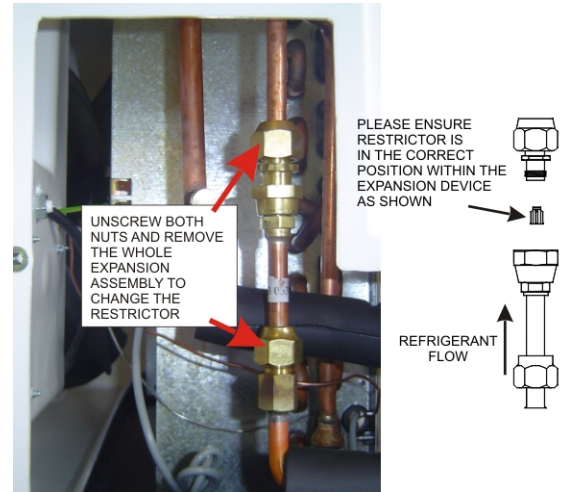

INTERCONNECTING PIPEWORK

1. The indoor unit has a low pressure charge of N₂, which may be safely released into the atmosphere before connection. The service valves on the outdoor unit should remain closed (IN, fully clockwise) until pipework has been fitted and system evacuated.
2. Connecting the pipework
 - a. Remove the flare nuts from the suction and liquid service valves.
 - b. Ensure that the suction line is fully insulated: if an expansion line is used this should also be fully insulated.
 - c. Place the flare nuts over the incoming pipework and flare the pipe ends. The use of a little refrigeration oil on the flaring tool will help.
 - d. Connect the pipework between the units. Do not leave pipe ends, valves etc. open to the atmosphere.
R407C is very hygroscopic and will absorb damaging levels of moisture if left open. Always use two spanners when tightening the flare nuts to avoid twisting the pipes. Use a small amount of refrigerant oil on the mating surfaces.
 - e. Sight glasses and filter driers are not necessary, but if required should be fitted between the outdoor unit liquid shut off valve and the expansion device.

CKC REFRIGERANT

EVACUATING

1. Connect a vacuum pump to the service ports on the outdoor unit valves and evacuate the system to 1000 microns (1 Torr) or better and allow to be held for a minimum of 15 minutes.
2. Replace the caps on the service ports, (torque to 25NM).

ADDING REFRIGERANT

1. All units are fitted with head pressure control. The link wire across the orange terminals allows the fan to operate at full speed. **THIS SHOULD BE REMOVED AFTER CHARGING**
2. If a manual HP cut-out is fitted, ensure that the reset button is depressed.
3. A 3 minute delay occurs between successive compressor operations.
4. R407C should be introduced through the Schrader valve on the indoor unit, or the service port on the suction service valve on the outdoor unit. **No other refrigerant must be used.**

No extra POE oil needed with liquid lines.

Charges shown are for guidance: actual charge will depend on the individual application. It is recommended that you charge to a sweat line on the outlet of the evaporator and/or a full sight glass if fitted.

Charge based on:-	Liquid line		Expansion line		
	1/4"	3/8"	3/8"	1/2"	5/8"
	25 g/m	60 g/m	16 g/m	30 g/m	48 g/m
Additional POE oil	25g per 350g of additional refrigerant to a maximum of 300g				

NOTE: The new 50 Series CKC are supplied with a Nitrogen holding charge. See pages 12 & 13 for refrigerant charge information.

5. Run the system for a few minutes to allow it to stabilize. Where possible, charge to a sweat line on the evaporator. Typical suction pressure on short lines at UK conditions should be approx. **3.8bar (55 psig)**.
6. **Head pressure controller**
The head pressure controller is factory set to suit the refrigerant. It may be necessary to adjust this to suit site conditions, to raise or lower the nominal head pressure.

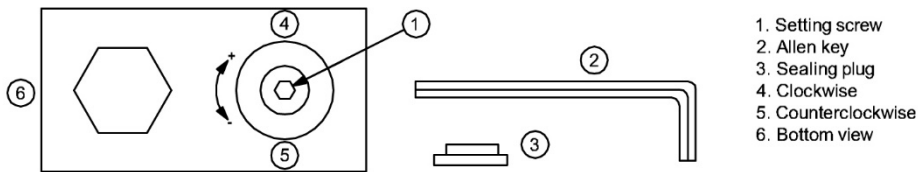

- a. With the system switched off, connect a high pressure gauge to the liquid line service valve.
- b. Switch on the system, and run for a few minutes to stabilise.
- c. The head pressure should be approximately:

R407C: 275-280 psig (18.9-19.6barg) to achieve this remove sealing plug and insert 2mm or 5/64" allen key into setting screw. Turn allen key clockwise (+) or counter clockwise (-) to readjust the setting. Do not turn setting screw **more than 3 turns clockwise (+3)**. Use following table as a quick guideline for setting:

After adjustment, re-insert sealing plug and make sure that it is properly fitted. IP65 protection requires firmly sealed plug

NOTES:

Tolerances for condensing temperatures setpoint: $\pm 2K$

Min fan speed (0 rpm) and fan cut in pressure 200 psig (13.8 barg) are factory set and not adjustable.

NOTE: The condenser fan may stop if the operating pressure drops below 200 psig (13.8 barg)

CXE PUMP DOWN 17 SERIES MATCHED WITH CKC 50 SERIES UNITS WITH MICROCHANNEL COIL

System		Part Number		Liquid Line								
		CXE	CKC	5	10	15	20	25	30	35	40	45
R407C	CX(E)30 + CKC20	55917006	55050800	829	954	1079	1204					
	CX(E)40 + CKC30	55917007	55050801	1034	1334	1634	1934	2234	2534	2834	3134	3434
	CX(E)50 + CKC50	55917008	55050803	1366	1666	1966	2266	3816	4366	4916	5466	6016
	CX(E)70 + CKC80	55917009	55050805	1490	1790	2090	2390	3940	4490	5040	5590	6140
	CX(E)90 + CKC90	55917010	55050806	2400	2950	3500	4050	6100	6960	7820	8680	9540

LOW TEMPERATURE CXE PUMP DOWN 17 SERIES MATCHED WITH CKC 50 SERIES UNITS WITH MICROCHANNEL COIL

System		Part Number		Liquid Line								
		CXE	CKC	5	10	15	20	25	30	35	40	45
R407C	CXE 40 + CKC 20	55917007	55050800	739	864	989	1114					
	CXE 50 + CKC 40	55917008	55050802	956	1256	1556	1856	3406	3956	4506	5056	5606
	CXE 70 + CKC 60	55917009	55050804	1350	1650	1950	2250	3800	4350	4900	5450	6000
	CXE 90 + CKC 80	55917010	55050805	1590	1890	2190	2490	4040	4590	5140	5690	6240

ELECTRICAL CONNECTIONS

- Cables are routed to the terminal block via the cable cord grips at the rear of the unit and then through the back of the electric box (see page 2).
- Cables **MUST** be size compatible with the recommended system fuse.

FUSES

SYSTEM	COOL ONLY	WITH ELECTRIC HEATER
	1PH	1PH
CXE 30	5A	16A
CXE 40	5A	16A
CXE 50	5A	16A
CXE 70	5A	16A
CXE 90	5A	16A

SYSTEM	1PH	3PH
CKC 20	16A	-
CKC 30	16A	-
CKC 40	20A	-
CKC 50	16A	-
CKC 60	20A	-
CKC 80	25A	10A/PH
CKC 90	25A	16A/PH

WIRING DIAGRAM

CXE PUMP DOWN

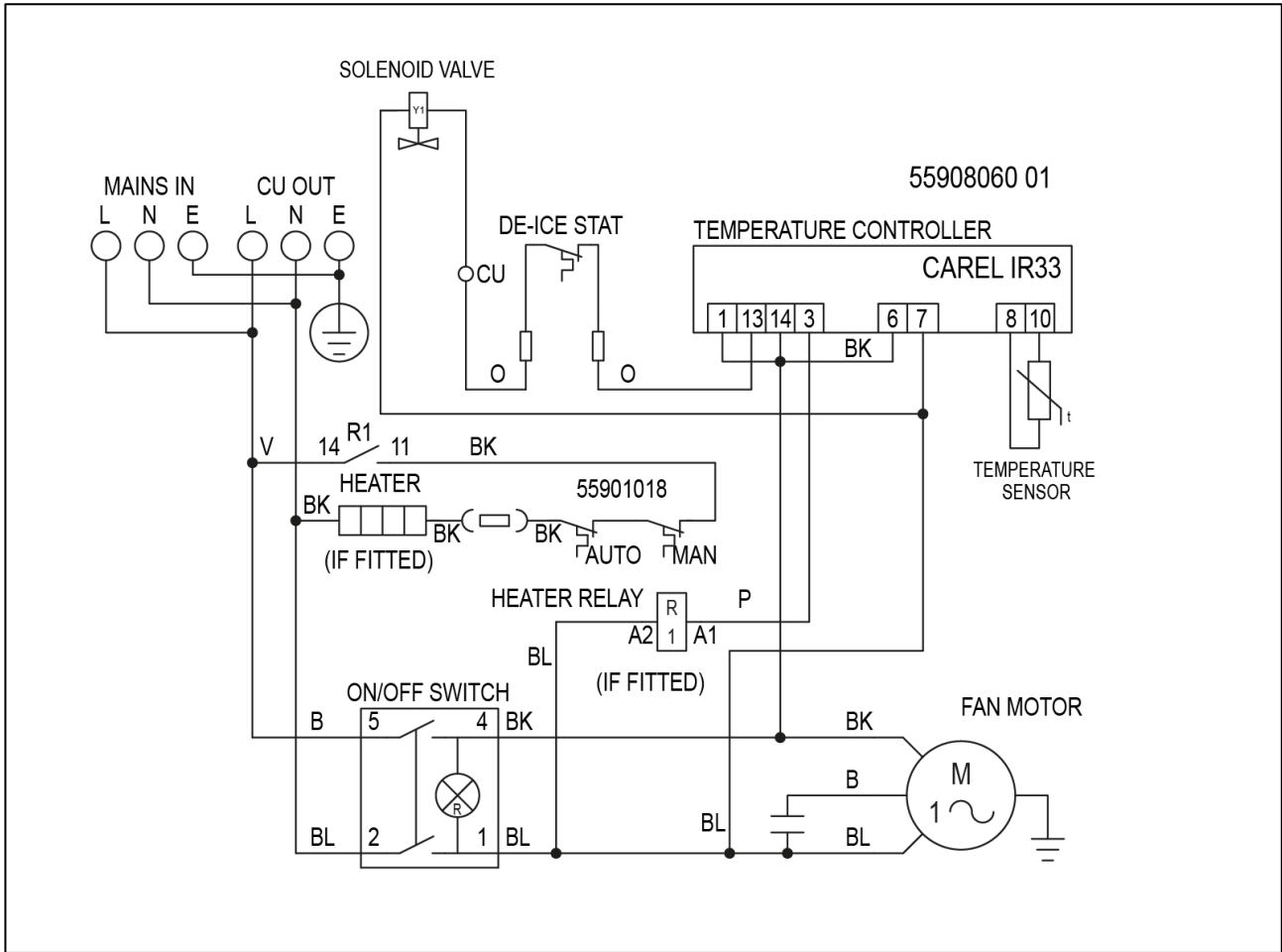

Note: Only 'Mains in' supply needs connecting when running system on pump down, no need to connect to 'CU OUT' Terminals

CKC PUMP DOWN

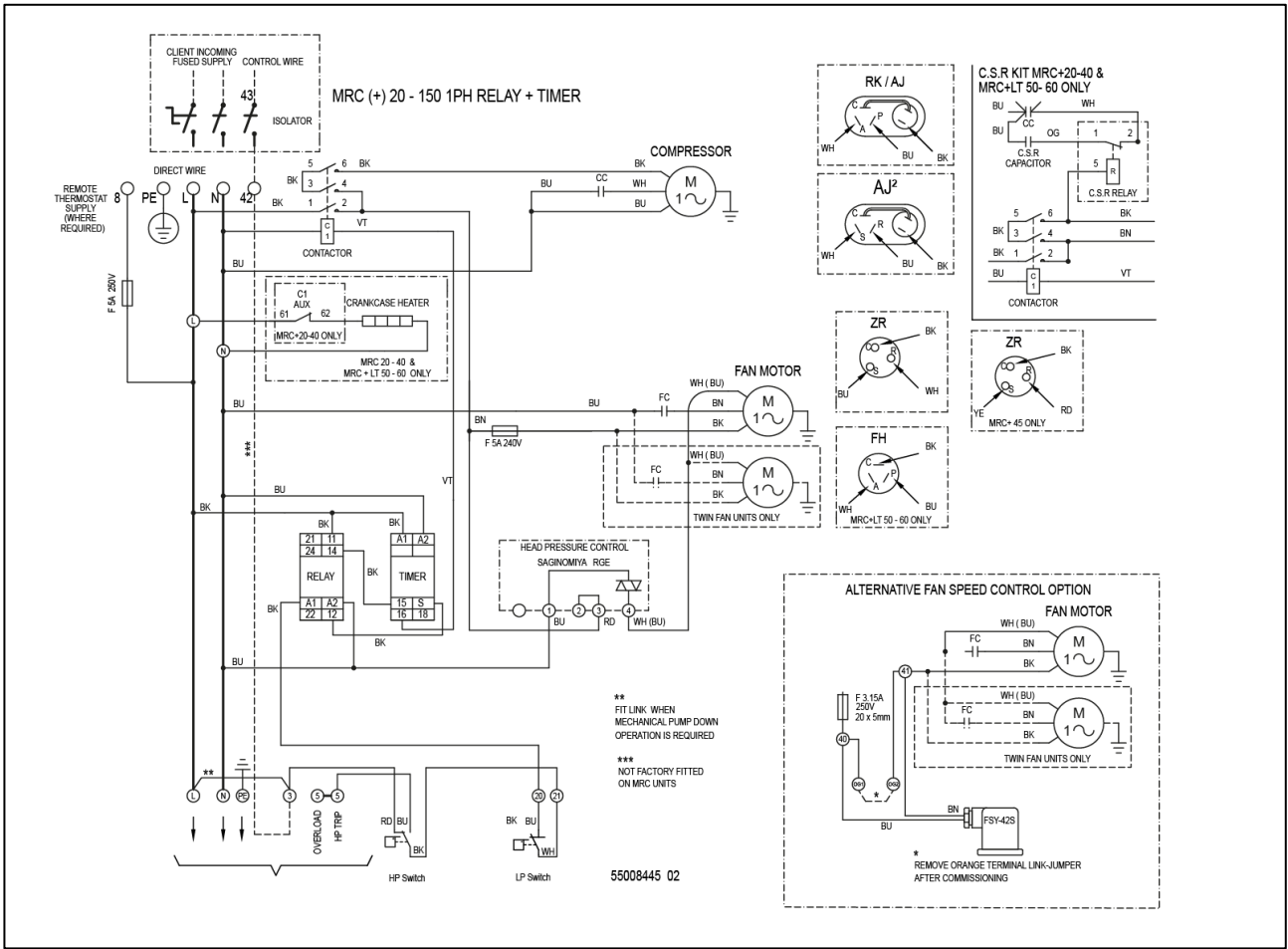

Note: Only 'Mains in Live, Neutral & Earth' supply needs connecting when running system on pump down, no need to connect to 'Remote thermostat -8' or 'Control wire - 42' or 'To Evaporator unit' Terminals

TIMER RELAY SETTINGS

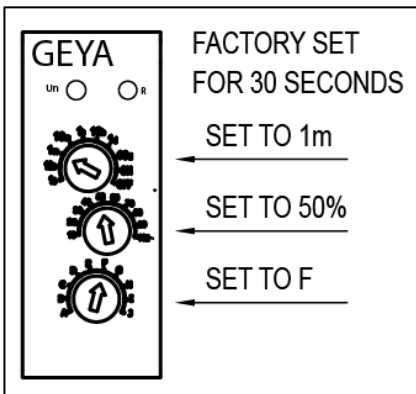

Note: Set for minimum compressor off time, minimum 30 seconds

CXE ELECTRONIC COOLING SYSTEM CONTROLS

CAREL IR33 Controller

ON/OFF SWITCH

The switch operates the fan motor and is illuminated when power is supplied to the indoor unit. When switched OFF, the fan stops, the switch remains illuminated and the crankcase heater in the outdoor unit (if fitted) remains live.

Minimum Set Temperature 8°C	
INDOOR UNIT	OUTDOOR UNIT
CX(E) 30	CKC 20
CX(E) 40	CKC 30
CX(E) 50	CKC 50
CX(E) 70	CKC 80
CX(E) 90	CKC 90

Minimum Set Temperature 4°C	
INDOOR UNIT	OUTDOOR UNIT
CXE 40	CKC 20
CXE 50	CKC 40
CXE 70	CKC 60
CXE 90	CKC 80

TEMPERATURE CONTROL (Do not set the controller below 4°C.)

The SET temperature is factory set at 12°C.

The digital display normally displays the return air temperature.

To change the SET temperature, press and hold down the SET button. If no alarms active, the 'St1' label appears and the current value is shown on the screen and will flash.

To change the Setpoint value, press ▲ and ▼ keys within 60 seconds.

The display will revert to the return air temperature after 60 seconds.

The fitted de-ice thermostat will activate a de-ice cycle when there is a build up of ice on the evaporator coil.

Cellarators will only heat a room if the electric heater option is fitted.

Displaying inputs on screen display

Press ▼ to display the current input. There are 6 inputs to select from to display onto the screen. These are as follows:

- b1: probe 1;
- b2: probe 2;
- di1: digital input 1;
- di2: digital input 2;
- St1: set point 1;
- St2: set point 2;

Press ▲ and ▼ to select the input to be displayed. Press set for 3 seconds to confirm your choice.

To display the live temperature in the room you need to select
b1: probe 1

WARNING

The following actions could damage your system:

1. Switching the unit OFF and ON quickly
2. Setting the unit to HEAT and then back to COOL quickly

NB: Allow at least 3 minutes between the above actions.

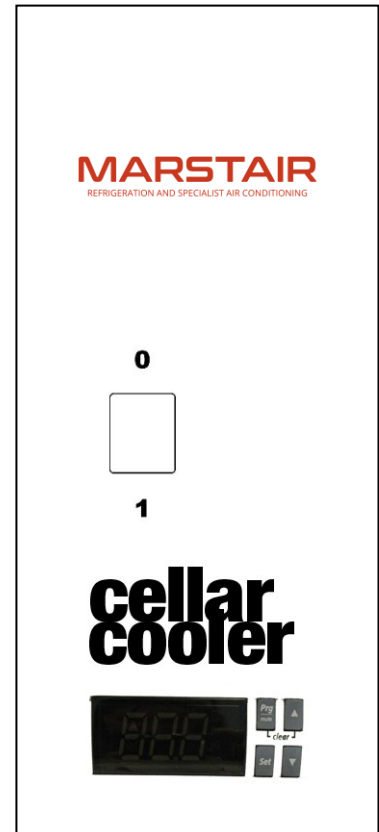

CKC INSTALLATION

MOUNTING

Whether floor or wall mounted, it is essential that the mounting surface is capable of supporting the unit weight. Leave space around the unit for air circulation and access for installation and maintenance.

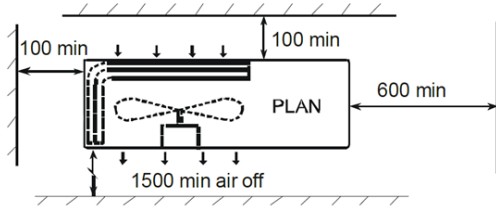

Dimensions in mm.

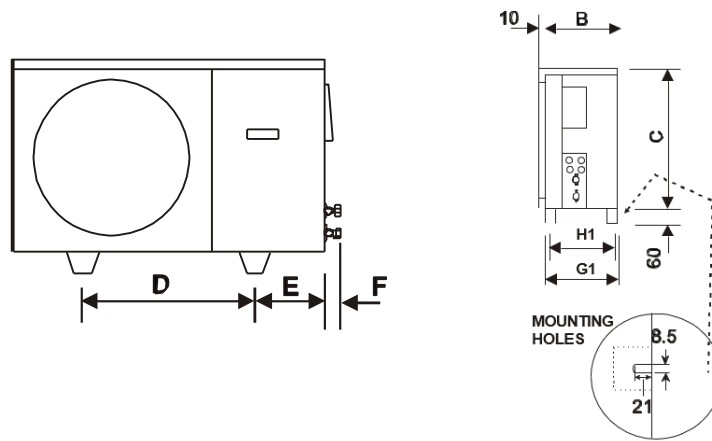

MODEL	A	B	C	D	E	F	G	H
CKC 20	900	300	560	525	185	60	295	275
CKC 30	900	300	560	525	185	60	295	275
CKC 40	900	300	560	525	185	60	295	275
CKC 50	1000	350	660	495	250	60	345	325
CKC 60	1000	350	660	495	250	60	345	325
CKC 80	1000	350	660	495	250	60	345	325
CKC 90	1000	350	760	495	250	70	345	325

- Individual pipe runs to a maximum of 45m (20m for CKC20), including 7.5m lift, are permissible with

CKC PIPEWORK

liquid lines. Performance is based on 7.5m pipe runs. Correctly sized pipes for each installation will result in no significant loss of capacity on extended pipe runs.

- Pipe sizes are based on:-
Minimum of 3.8 m/s (750 fpm) suction gas velocity for horizontal or downflow.
Minimum of 7.6 m/s (1500 fpm) suction gas velocity for upflow.
Maximum of 15.2 m/s (3000 fpm) suction gas.
- Where vertical risers exceed 3m, oil traps must be formed in the pipe. This will help ensure that oil returns to the compressor. Typically fit an oil trap every 3m with a trap at the bottom of the riser.

- In calculating equivalent lengths of pipe runs, the effect of bends and fittings must be taken into account. The table below covers the fittings most likely to be encountered in this installation.

The equivalent lengths of all the fittings in a pipe run should be added together and the total added to the actual pipe length in order to calculate the total equivalent length.

- Use the shortest possible route, avoiding sharp bends.
- Completely insulate the suction line, fully over the indoor unit drain tray.

CX INDOOR UNIT COMPONENT IDENTIFICATION

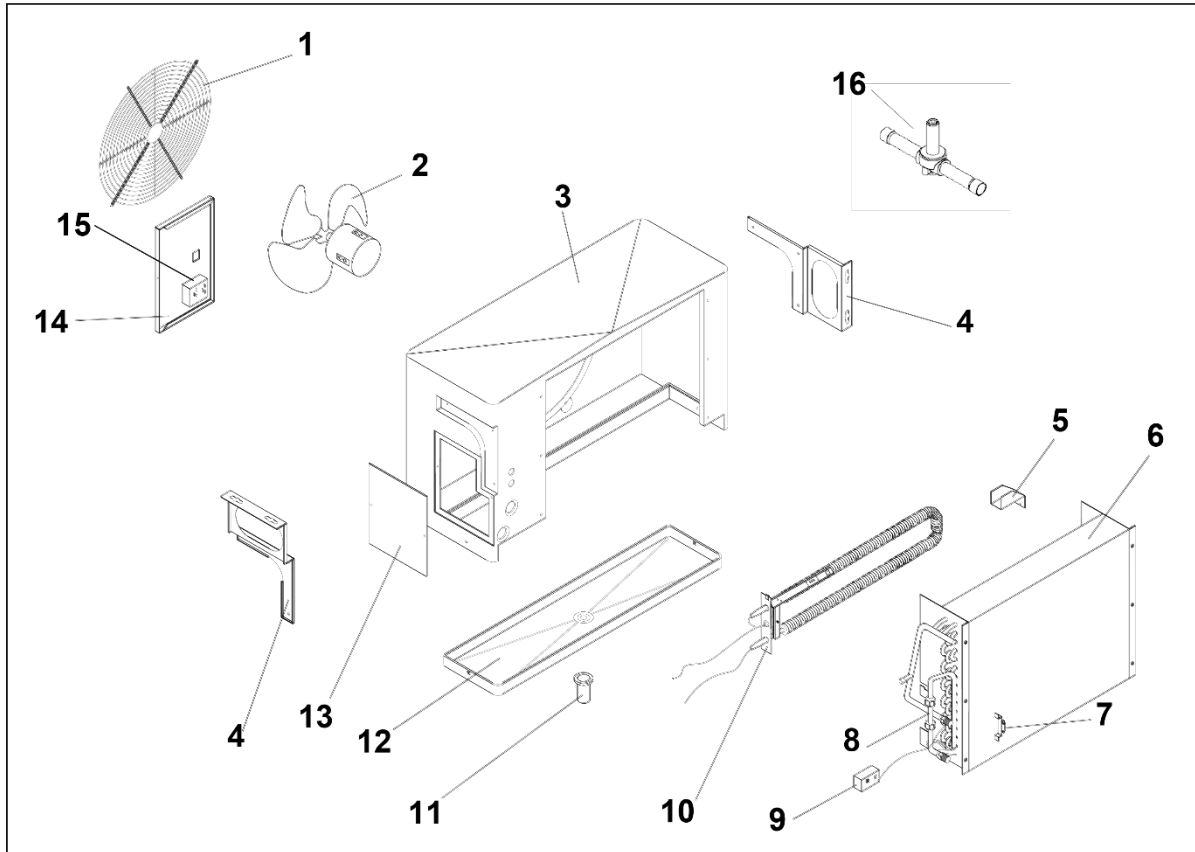

1	Grille	9	De-ice stat
2	Fan / motor	10	Heater assembly (option)
3	Case	11	Drain stub adaptor
4	Wall / ceiling mounting brackets	12	Drain tray
5	Heater bracket	13	Side access panel
6	Coil assembly	14	Electrics box door
7	Thermostat bulb & bracket	15	Thermostat
8	Restrictor assembly	16	Solenoid Valve

INSIDE VIEW OF ELECTRICS BOX

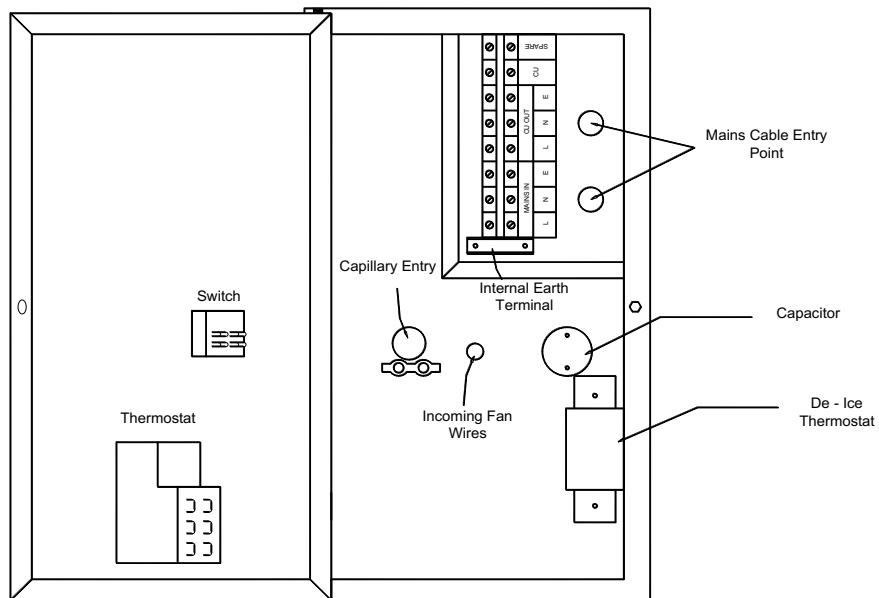

CKC OUTDOOR UNIT COMPONENT IDENTIFICATION

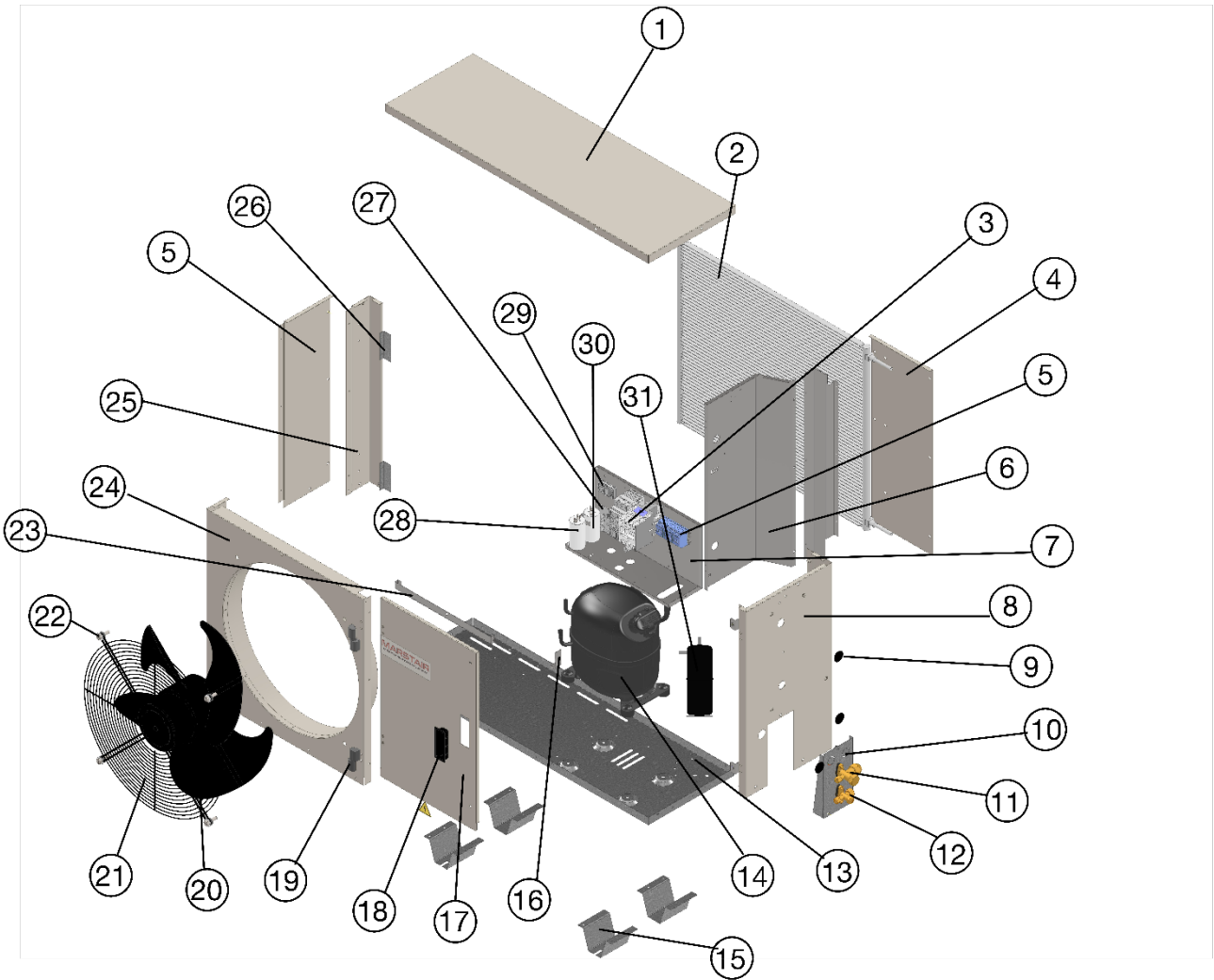

1	LID	12	SERVICE VALVE (LIQUID)	22	DAMPING WASHER
2	MICROCHANNEL COIL	13	BASE	23	DOOR BRACKET
3	CONTACTOR & OVERLOAD	14	COMPRESSOR	24	FASCIA PANEL
4	REAR ACCESS PANEL	15	MOUNTING FOOT	25	CORNER PANEL
5	TERMINALS	16	DOOR STOPPER	26	COIL BRACKET
6	BULKHEAD PANEL	17	HINGED DOOR	27	FAN SPEED CONTROLLER
7	ELECTRICS BOX	18	HANDLE	28	FAN CAPACITOR
8	SIDE PANEL	19	HINGE	29	TIMER
9	BLANKING PLUGS	20	FAN / MOTOR ASSEMBLY	30	COMPRESSOR CAPACITOR
10	VALVE PANEL	21	FAN GUARD	31	RECEIVER
11	SERVICE VALVE (SUCTION)				

Commissioning Check List

The following information will be required to validate your 5yr parts warranty

Check and record	Value	Time Held For
Leak (tightness) test pressure	(bar)	(min)
Strength (pressure) test pressure	(bar)	(min)
Evacuation level	(microns)	(min)

	Value
Low pressure (gauge)	(barg)
Suction line temperature	(°C)
Evaporator superheat	(K)
Evaporator air ON / OFF	(°C) (°C)
High pressure (gauge)	(barg)
Liquid line temperature	(°C)
Condenser sub cooling	(K)
Condenser air ON / OFF	(°C) (°C)
Compressor current	(A)
Head pressure control set	(Y/N)
Refrigerant type	
Charged weight	(Kg)
Additional POE oil added	(g)
Pipe run length	(m)
Suction pipe size	(")
Liquid / Expansion pipe size	(")