

TECHNICAL MANUAL



CXE SPLIT SYSTEMS

INDEX

<u>CONTENTS</u>	<u>PAGE</u>
PART NUMBERS, OPTIONS, UNIT COMBINATIONS, DIMENSIONS & WEIGHTS	3-4
PERFORMANCE DATA & AIR FLOW	4
SOUND POWER AND SOUND PRESSURE LEVELS	5
ELECTRICAL DATA	6
CXE	
DIMENSIONS	7
INSTALLATION: CONTENTS & PIPEWORK	8
ELECTRICAL: FUSES & WIRING DIAGRAMS	9
CONTROLLER SETTINGS	10
CKC	
INSTALLATION: DIMENSIONS	11
PIPEWORK	12
ELECTRICAL	13 -14
R407C REFRIGERANT	15 -17
END OF LIFE REQUIREMENTS	17
COMPONENT IDENTIFICATION	
CXE UNITS	18
CKC UNITS	19

GENERAL

1. TEV Ltd recommend that personnel working on this equipment be skilled and fully conversant with the appropriate Air Conditioning, Refrigeration and Electrical practices and have sound knowledge of current Industrial Safe Working practices.
2. CXE models are electronic control units that use R407C refrigerant; they provide cooling within the range of 2.8 – 6.8 kW. These units are matched with CKC+ outdoor units to complete a system.
3. These units contain live electrical components, moving parts and refrigerant under pressure. Always site out of reach of children and protect from vandalism.
4. The data plate only gives information for the CXE unit. For system details add input power and current of indoor and outdoor unit, including any heater load.
5. **Expansion devices are not fitted as standard, and would need to be ordered separately to match with the pipe run.**

PART NUMBERS

MODEL		Part No.
CXE30	MASTER	55917026
CXE50	MASTER	55917028
CXE70	MASTER	55917029
CXE30	SLAVE	55917056
CXE 50	SLAVE	55917058
CXE70	SLAVE	55917059

MODEL	Part No.	
	1ph	3ph
CKC 50	55020722	55020776
CKC 80	55020723	55020724
CKC 90	55020771	55020778
CKC 100	-	55020779
CKC 130	-	55020780
CKC 150	-	55020781
CKC 165	-	55020782
CKC 180	-	55020783
CKC 200	-	55020784

UNIT COMBINATIONS

Evaporators	Condensing unit
2 x CXE30	CKC 50
2 x CXE50	CKC 80
2 x CXE50	CKC 90
2 x CXE50	CKC 100
2 x CXE70	CKC 100
2 x CXE70	CKC 130
2 x CXE70	CKC150
3 x CXE50	CKC 100
3 x CXE50	CKC 130
3 x CXE50	CKC 150
3 x CXE50	CKC 165
3 x CXE70	CKC 100
3 x CXE70	CKC 130
3 x CXE70	CKC 150
3 x CXE70	CKC 165
3 x CXE70	CKC 180
3 x CXE70	CKC 200

OPTIONS

OPTIONAL KITS	
PART NUMBER	DESCRIPTION
55900721	3kW heater (MASTER)
55900722	3kW heater (SLAVE)

If heater is to be fitted to a slave it must also be fitted to the master.

DIMENSIONS & WEIGHTS

MODEL	UNPACKED				PACKED			
CXE	HEIGHT	WIDTH	DEPTH	WEIGHT	HEIGHT	WIDTH	DEPTH	WEIGHT
30	483	845	320	18	530	950	370	21
50	483	845	320	20	530	950	370	23
70	483	845	320	23	530	950	370	26

MODEL	UNPACKED					PACKED				
CKC	HEIGHT	WIDTH	DEPTH	WEIGHT 1ph	WEIGHT 3ph	HEIGHT	WIDTH	DEPTH	WEIGHT 1ph	WEIGHT 3ph
50	720	1000	350	64	62	720	1080	340	66	64
80	720	1000	350	66	64	720	1080	340	68	66
90	820	1000	350	76	73	820	1090	390	78	75
100	820	1000	350	-	81	820	1090	390	-	83
130	1080	1000	425	-	101	1080	1090	465	-	105
150	1080	1000	425	-	103	1080	1090	465	-	107
165	1080	1000	425	-	103	1080	1090	465	-	107
180	1275	1100	425	-	118	1280	1215	465	-	123
200	1275	1100	425	-	173	1280	12515	465	-	178

PERFORMANCE DATA (kW)

Evaporators	Condensing unit	Duty at 8°C kW	Duty at 12.7°C kW
2 x CXE30	CKC 50	3.90	4.80
2 x CXE50	CKC 80	5.60	6.90
2 x CXE50	CKC 90	6.40	7.30
2 x CXE50	CKC 100	7.30	8.20
2 x CXE70	CKC 100	7.60	8.80
2 x CXE70	CKC 130	8.40	10.00
2 x CXE70	CKC 150	9.50	11.00
3 x CXE50	CKC 100	7.70	9.10
3 x CXE50	CKC 130	8.50	10.20
3 x CXE50	CKC 150	9.80	11.30
3 x CXE50	CKC 165	10.80	12.50
3 x CXE70	CKC 100	8.00	10.00
3 x CXE70	CKC 130	8.90	11.10
3 x CXE70	CKC 150	10.0	11.50
3 x CXE70	CKC 165	11.00	12.70
3 x CXE70	CKC 180	12.50	14.00

At 27°C External Ambient

AIR FLOWS

MODEL	m ³ /s
CXE 30	0.61
CXE 50	0.66
CXE 70	0.58

MODEL	m ³ /s
CKC 50	0.97
CKC 80	0.97
CKC 90	0.97
CKC 100	0.97
CKC 130	1.85
CKC 150	1.85
CKC 165	1.85
CKC 180	1.85

SOUND POWER AND SOUND PRESSURE LEVELS

INDOOR UNIT

MAXIMUM SPEED	SOUND POWER LEVELS						SOUND PRESSURE LEVELS	
	Frequency Hz						dB(A)	NC
	125	250	500	1K	2K	4K		
CXE 30	69.1	67.7	67.6	65.6	62.2	56.0	55	48
CXE 50	71.7	69.2	69.1	67.1	63.2	58.5	56	50
CXE 70	70.1	68.2	68.6	66.1	63.2	57.5	56	49

Sound Power Levels were obtained in full accordance with the direct method of BS EN ISO3174:2000.

Levels are shown in dB with a standard reference of 1 pW.

Sound Pressure Levels in dB(A) refer to semi-hemispherical radiation (wall or ceiling mounted) at a distance of 1.5m from the front of the unit, with the fan operating at full speed.

OUTDOOR UNIT

MAXIMUM SPEED	SOUND POWER LEVELS						SOUND PRESSURE LEVELS	
	Frequency Hz						dB(A)	NC
	125	250	500	1K	2K	4K		
CKC 50	74	68	67	66	61	54	49	44
CKC 80	71	69	68	65	60	54	49	43
CKC 90	82	72	69	69	63	57	52	47
CKC 100	79	74	72	69	64	58	53	47
CKC 130	73	70	70	69	65	57	52	47
CKC 165	73	70	70	69	66	58	57	51
CKC 150	73	70	70	69	66	58	57	51
CKC 180	73	72	72	69	66	58	59	53

Sound Power Levels were obtained in full accordance with the direct method of ISO 3741: 1988. Levels are shown in dB with a standard reference of 1 pW.

Sound Pressure Levels in dB(A) refer to semi-hemispherical radiation (wall or floor mounted) at a distance of 3m from the front of the unit, with the fan operating at full speed; (add 3dBA or 3NC for units at an intersection of a wall, add 1dBA or 1NC for high level wall mounted units).

ELECTRICAL DATA

UNIT ELECTRICAL LOADS [230V 50Hz 1Ph (A) or 400V 50Hz 3Ph (A/Ph)]

MODEL	FAN MOTOR	HEATER
CXE 30	0.8	13.0
CXE 50	0.8	13.0
CXE 70	0.8	13.0

MODEL	1ph			3ph		
	Power (nominal) (kW)	Starting current LRA (A)	Nominal current FLA (A)	Power (nominal) (kW)	Starting current LRA (A)	Nominal current FLA (A)
CKC 50	2.0	58	8.9	1.9	26	4.2
CKC 80	3.0	76	11.5	3.0	40	4.9
CKC 90	4.2	114	16.9	4.1	48	7.1
CKC 100	-	-	-	4.3	51	7.2
CKC 130	-	-	-	4.4	62	7.7
CKC 165	-	-	-	5.3	68	8.7
CKC 150	-	-	-	6.0	71	9.5
CKC 180	-	-	-	7.0	71	11.9

CXE DIMENSIONS

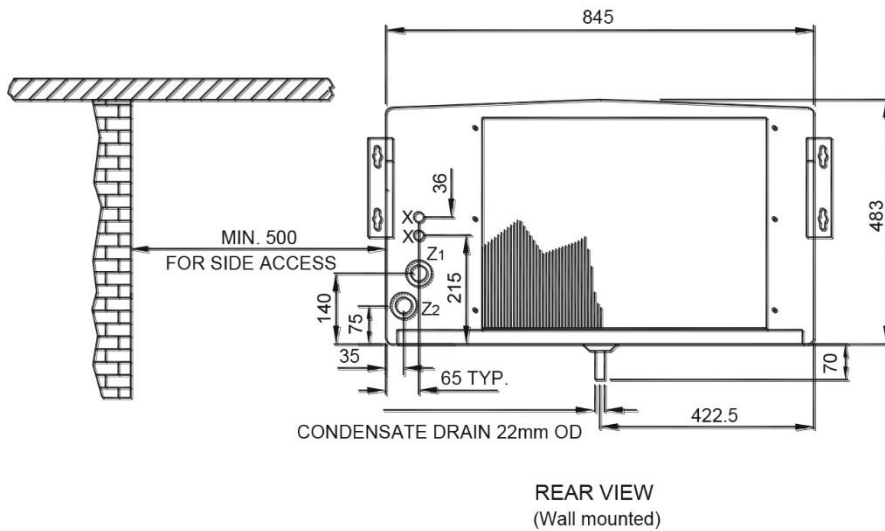
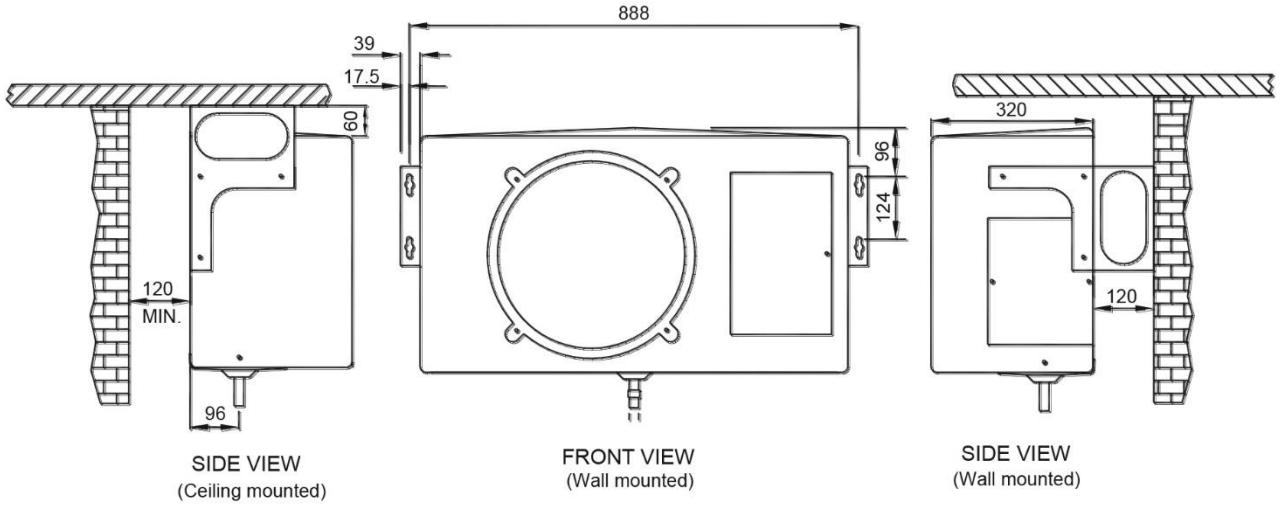
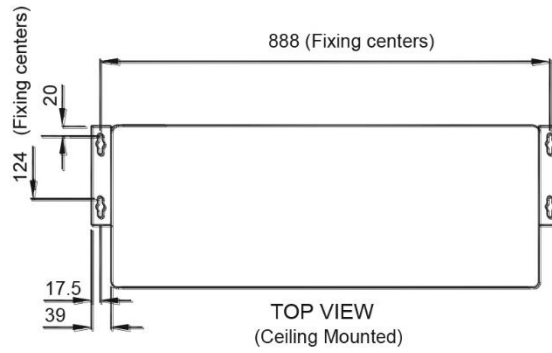

- X = Interconnecting Wiring
- Z1 = Suction
- Z2 = Liquid / Expansion

CXE INSTALLTION

CONTENTS	
PARTS DESCRIPTION	ACTION
Envelope containing operating instructions and Declaration of Conformity	Pass to the end user.
Drain Stub/Nut/Gasket	Fitted by installer.
Drain stub adaptor	Convert to 3/4" drain if required.
Mounting brackets plus fixings	Use to hang unit.

The unit may be mounted on a wall or solid ceiling using brackets supplied. It should be matched with the appropriately sized outdoor unit; this instruction should be used in conjunction with the outdoor unit installation instructions.

1. Fit all kits prior to installing the unit. (Heater kit is easier to fit when unit has been mounted).
2. Ensure that the mounting surface will support the operating weight of the unit (see table below).
3. Mark out the mounting positions and drill holes to suit 6mm rawlbolt shields or equivalent strength fasteners (ensure that the unit is positioned to give sufficient access (min 0.5m) to the electrics access side).
4. Fix the mounting brackets to the unit in the correct position for wall or ceiling mounting.
5. Raise the unit into position and secure the fixings, ensuring that it is square and level.
6. Remove the drain tray then fit the drain stub, nut & gasket (Fig.1). Refit the drain tray.

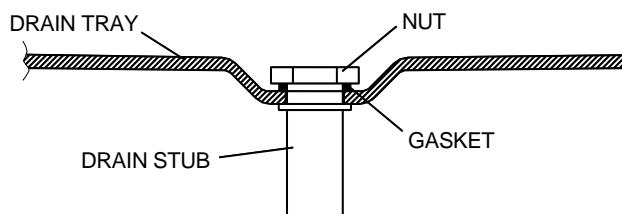

Fig.1

CXE PIPEWORK

NITROGEN CHARGE

The unit contains a small charge of dry nitrogen, which should be discharged into the atmosphere. This is a non-toxic, non-ozone depleting gas with no global warming potential.

PIPE CONNECTIONS

Pipework is terminated with 2 flare nuts & bonnets. Access is via the rear right hand side. Pipes exit the unit through holes in the back panel.

INDOOR UNIT	CXE 30	CXE 50	CXE 70
LIQUID / EXPANSION	3/8"	3/8"	1/2"
SUCTION	1/2 "	1/2 "	5/8"

CONDENSATE DRAIN

Push fit connections are widely available for the 7/8" (22mm) OD condensate drain and 3/4"(19mm) ID drain stub adaptor. Alternatively 7/8" (22mm) bore plastic tubing may be fitted directly to the stub/adaptor with a hose clamp. Take care not to overtighten hose clamps as this could damage the stub pipe.

CXE ELECTRICAL CONNECTIONS

- Cables are routed to the terminal block via the cable cord grips at the rear of the unit and then through the back of the electrics box (see page 2).
- Cables **MUST** be size compatible with the recommended system fuse.

FUSES

1PH FUSE SIZE (Cooling Only Systems)														
CKC	15	20	30	40	50	60	80	90	100	130	150	165	180	200
FUSE	16	16	16	20	16	20	25	32	-	-	-	-	-	-

3PH FUSE SIZE (Cooling Only Systems)													
CKC	30	40	50	60	80	90	100	130	150	165	180	200	
FUSE	10	10	10	10	10	16	16	16	20	20	25	32	

Note: On 3 ph systems the supply must go to the MCU+ outdoor unit and then to the CXE indoor unit. For fuse sizing with electric heating contact Marstair technical department.

WIRING DIAGRAM

MASTER (Also shows optional heater)

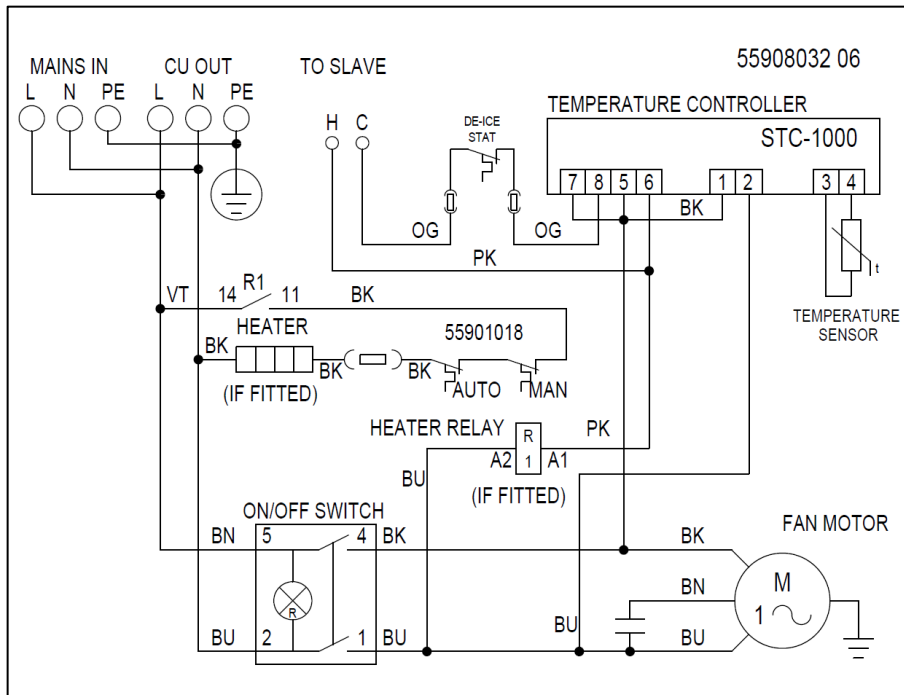

SLAVE (Also shows optional heater)

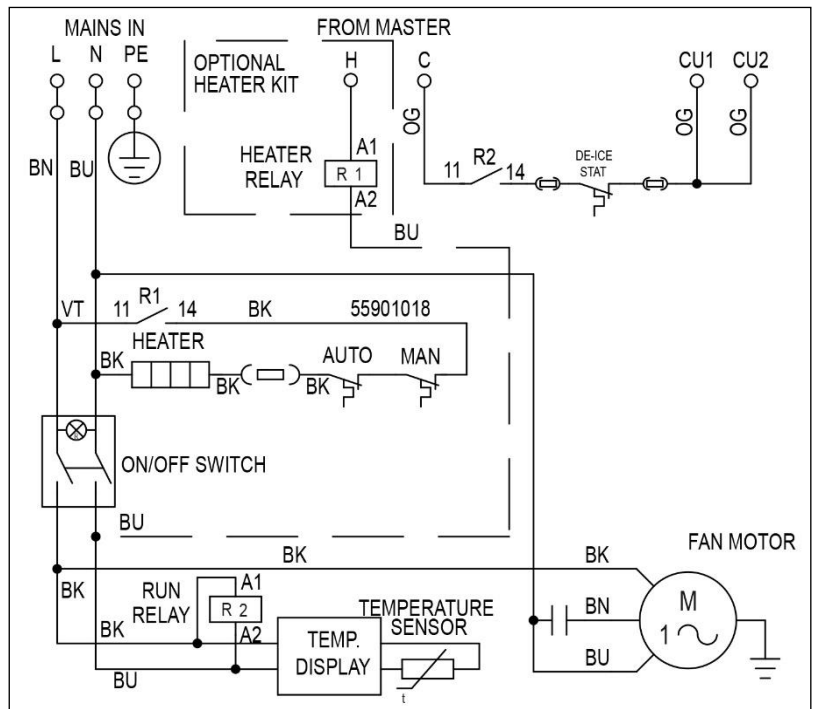

CKC INSTALLATION

MOUNTING

Whether floor or wall mounted, it is essential that the mounting surface is capable of supporting the unit weight. Leave space around the unit for air circulation and access for installation and maintenance.

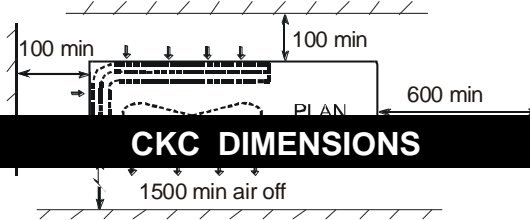

CKC DIMENSIONS

CKC 50-100 (Dimensions in mm.)

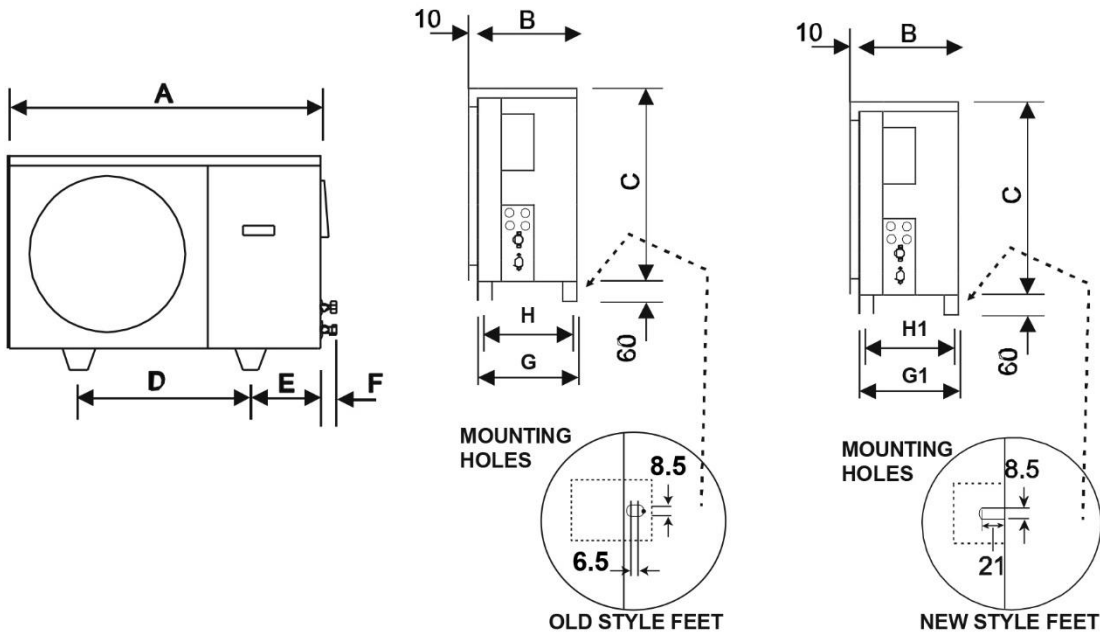

MODEL	A	B	C	D	E	F	G	H	G1	H1	Weight (kg)	
											1 Ph	3 Ph
CKC 50	1000	350	660	570	213	60	383	358	345	325	64	62
CKC 80	1000	350	660	570	213	60	383	358	345	325	66	64
CKC 90	1000	350	760	495	250	70	383	358	345	325	76	73
CKC 100	1000	350	760	495	250	70	383	358	345	325	--	81

CKC 130 – 180 (Dimensions in mm.)

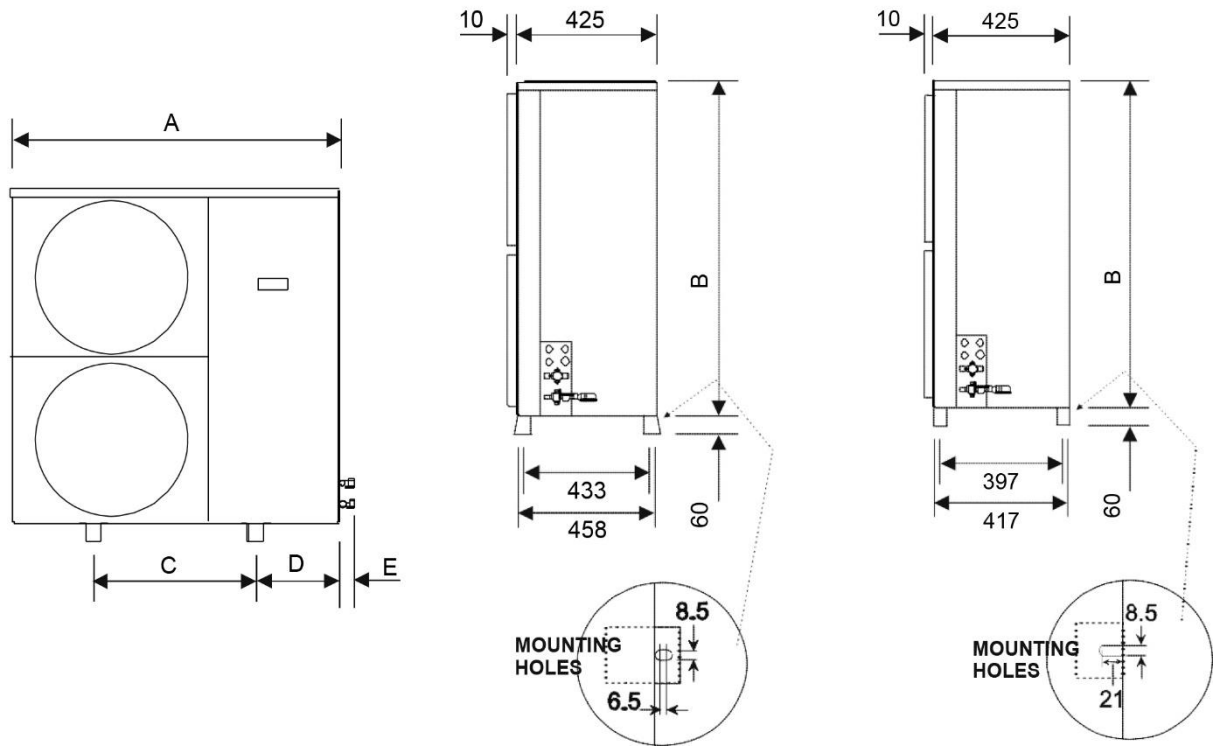

MODEL	A	B	C	D	E	Weight (kg)
CKC 130	1000	1020	495	251	100	101
CKC 150	1000	1020	495	251	100	103
CKC 165	1000	1020	495	251	100	103
CKC 180	1100	1215	675	211	95	118

1. Individual pipe runs to a maximum of 20m, including 7.5m lift, are permissible with liquid lines, 80m with expansion lines, provided good refrigeration practice is followed. Performance is based on 7.5m pipe runs. Correctly sized pipes for each installation will result in no significant loss of capacity on extended pipe runs.
 - a) Pipe sizes are based on:-
 Minimum of 3.8 m/s (750 fpm) suction gas velocity for horizontal or downflow.
 Minimum of 7.6 m/s (1500 fpm) suction gas velocity for upflow.
 Maximum of 15.2 m/s (3000 fpm) suction gas.
 - b) Where vertical risers exceed 3m, oil traps must be formed in the pipe. This will help ensure that oil returns to the compressor. Typically fit an oil trap every 3m with a trap at the bottom of the riser.
2. In calculating equivalent lengths of pipe runs, the effect of bends and fittings must be taken into account. The table below covers the fittings most likely to be encountered in this installation.

 The equivalent lengths of all the fittings in a pipe run should be added together and the total added to the actual pipe length in order to calculate the total equivalent length.
3. Use the shortest possible route, avoiding sharp bends.
4. Completely insulate the suction line, fully over the indoor unit drain tray.

TYPICAL FITTING LOSSES, in equivalent straight lengths of pipe (metres).

Fitting	Pipe Size (outside diameter in inches)						
	3/8	1/2	5/8	3/4	7/8	1-1/8	1-3/8
45° Bend	0.12	0.15	0.18	0.21	0.24	0.30	0.40
90° Bend R/d = 1	0.37	0.43	0.49	0.55	0.61	0.79	1.00
90° Bend R/d = 1.5	0.24	0.27	0.30	0.37	0.43	0.52	0.70
180° Bend C/d = 1.5	0.73	0.91	1.10	1.28	1.46	1.83	2.38
180° Bend C/d = 2.5	0.46	0.55	0.64	0.76	0.85	1.07	1.40
90° Elbow	0.67	0.85	1.04	1.25	1.46	1.89	2.32
R = Radius of bend d = Diameter of tube C = Centres of bend							

The above figures should be used as a guide only - refer to the fitting suppliers information for precise data.

USING SUCTION AND EXPANSION LINES

The expansion assembly must be removed from the indoor unit and connected to the outdoor unit allowing a pipe run of up to 80m, including a maximum lift of 20m.

Fully insulate both the suction and expansion lines, including the expansion device: ensure the pipes are insulated well over the drain tray at the indoor unit.

MODEL		MAXIMUM LENGTH OF EQUIVALENT SUCTION LINE PIPE (m)							EXPANSION LINES PIPE SIZES			
		SUCTION LINE PIPE SIZES										
UNIT SIZE	TYPE	$\frac{3}{8}$	$\frac{1}{2}$	$\frac{5}{8}$	$\frac{3}{4}$	$\frac{7}{8}$	$1\frac{1}{8}$	$1\frac{3}{8}$	$\frac{3}{8}$	$\frac{1}{2}$	$\frac{5}{8}$	$\frac{3}{4}$
50	Common		7.5	18	50	80			7.5	50	80	
	Twin	7.5	23	80					80			
80	Common			11	30	80				50	80	
	Twin		15	50	80				50	80		
90	Common			10	25	55	80			20	80	
	Twin		10	36	80				7.5	80		
100	Common			7.5	22	45	80			15	80	
	Twin		7.5	18	50	80			7.5	50	80	
	Triple		15	50	80				50	80		
130	Common				15	30	80			12	60	80
	Twin		7.5	18	50	80			7.5	50	80	
	Triple		10	36	80				7.5	80		
150	Common				12	27	80			8	50	80
	Twin			14	36	80			7.5	50	80	
	Triple		10	36	80				7.5	80		
165	Common				8	18	60	80		7.5	40	80
	Triple		7.5	18	50	80			7.5	50	80	
180	Common				7.5	16	55	80		7.5	35	80
	Triple		7.5	18	50	80			7.5	50	80	

PIPE CONNECTIONS

Units are supplied with the following male flare connections (sizes in inches):

Model	CKC							
Size	50	80	90	100	130	150	165	180
Expansion	3/8	1/2	1/2	1/2	1/2	1/2	1/2	1/2
Suction	1/2	5/8	5/8	3/4	3/4	3/4	3/4	7/8*

CONNECTING THE UNITS

1. Ensure both service valves on the unit are closed (clockwise) before commencing installation.
2. If a expansion assembly requires cleaning:
 - a. Remove the entire expansion assembly from the outdoor unit.
 - b. Split the expansion assembly in the middle and remove the existing restrictor.
 - c. Drop the new restrictor vertically into the field connector.
 - d. Reassemble in the vertical plane (field connector lowest) when reassembled the restrictor can be heard to be free to move if the assembly is shaken.
 - e. Refit the expansion assembly.
3. Connecting the pipework
 - a. Remove the flare nuts from the suction service valve and the expansion device as appropriate.
 - b. Ensure that both the suction and expansion lines are fully insulated.
 - c. Place the flare nuts over the incoming pipework and flare the pipe ends.
 - d. Connect the pipework between the units. Do not leave pipes ends, valves etc open to the atmosphere. Always use 2 spanners when tightening the flare nuts to avoid twisting the pipes. Use a small amount of refrigerant oil on the mating surfaces.
 - e. Sight glasses and filters driers are not necessary, but if required should be fitted between the outdoor unit liquid shut off valve and the expansion device on the CKC units.
 - f. CKC 180 has a 7/8" suction pipe with brazed connections. Use a protective shield to avoid scorching the side panel.

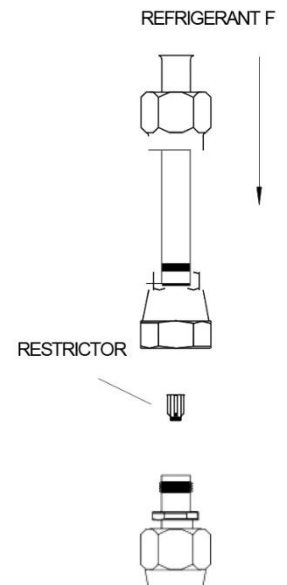

EVACUATING

With the valves closed, connect a vacuum pump to the service ports on the outdoor unit valves. Evacuate the interconnecting pipework and indoor unit to 1000 microns (1 Torr) or better. Allow this to be held for a minimum of 15 minutes

BRANCH LINE LENGTH

All branch lines must have the **same equivalent lengths** to ensure that the system is correctly balanced.

CKC ELECTRICAL

- The installer supplies mains, control and interconnecting cables: equipment must be earthed.
- Wiring must be carried out in accordance with local and national codes.
- Mains supply cables must be size compatible with the recommended fuse.
- An all pole isolator switch should be positioned within easy reach of the indoor/outdoor unit dependant on which receives the fuse supply.
- Cable clamps for use with stranded cables are supplied and should be used to secure incoming/outgoing cables. Installers must supply a method of securing solid sheathed cables.

3PH CKC

On 3 PH CKC it is possible for the scroll compressor to run backwards.

This becomes obvious on start up - the compressor will not develop a normal running pressure differential and the top will not become warm: it may be excessively noisy. If this happens, switch off the mains power and exchange the two supply phases **not** connected to the indoor unit. This will correct the rotation.

ISOLATOR SWITCHES

On a 3 phase system, ensure that the neutral contact of the isolator switch is an early make, late break type. This applies to all switches in the supply line. If in doubt, do not switch the neutral but connect it solidly.

WIRING

- Cable entry for the outdoor unit electrics is through the cabinet to a terminal block.
- Ensure that all connections are secure and that both units are earthed.
- CKC fan motors have a single speed and are ready for use at all outdoor temperatures.

NOTE: The CKC wiring diagram can be found on the inside of the front panel.

INTERCONNECTING WIRING

MASTER/SLAVE
(COOL ONLY)
INTERCONNECTING
WIRING

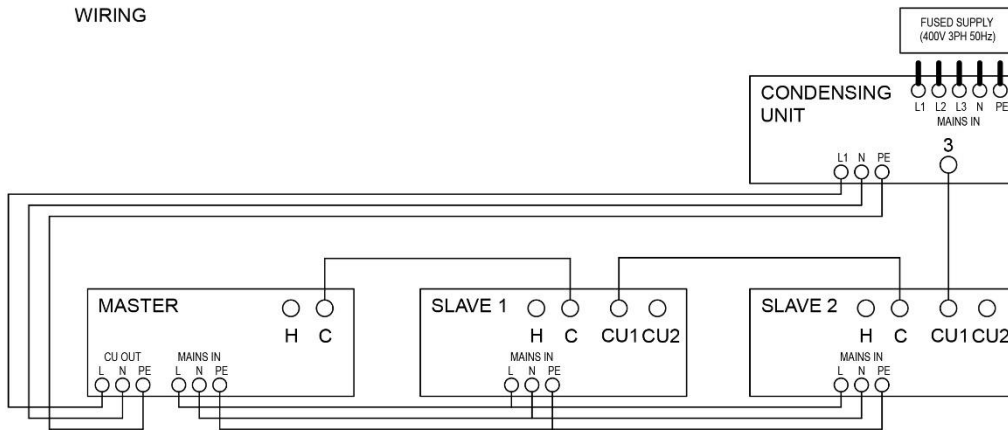

MASTER/SLAVE
COOL & HEAT
INTERCONNECTING
WIRING

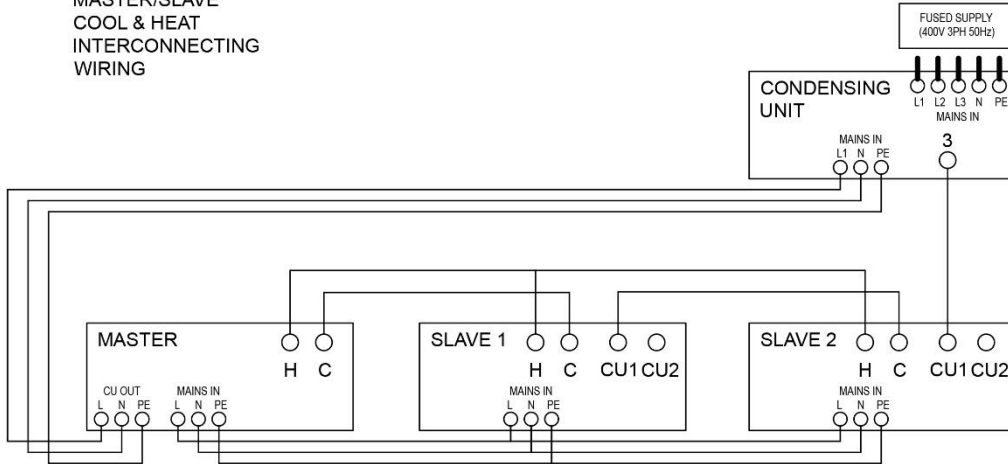

R407C REFRIGERANT

Charging the System:

1. Evacuate the system and interconnecting pipework ensuring the service valves are fully open.
2. Allow the evacuated system to draw in the majority of the refrigerant charge.
3. The final charge should be adjusted with the system running.
4. All units are fitted with head pressure control. The link wire across the orange terminals allows the fan to operate at full speed. **THIS SHOULD BE REMOVED AFTER CHARGING**
5. A random start delay of up to 1 minute occurs when mains is first applied. A 3 minute delay occurs between successive compressor operations on all systems.
6. Refrigerant and polyolester oil should be introduced through the Schrader valve in the service port on the suction service valve on the outdoor unit. **Ensure the refrigerant is the correct type, as shown on the rating plate.** R407C must always be added in the liquid state. See indoor installation instruction for refrigerant charge weight.
7. Run the system for a few minutes to allow it to stabilize. Where possible, charge to a sweat line on the evaporator. Typical suction pressures on short lines at UK conditions, with high speed evaporator fan, high speed condenser fan, should be; low temperature system approx 4.4 bar (65 psig).
8. **Systems should not be overcharged, to avoid liquid return to the compressor**

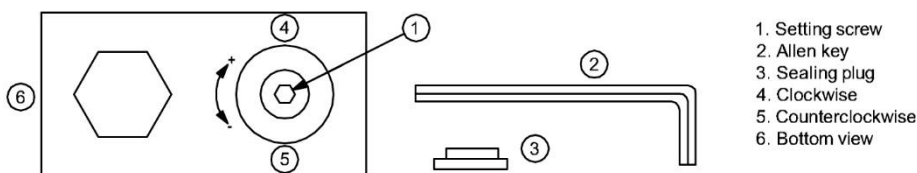

1. Setting screw
2. Allen key
3. Sealing plug
4. Clockwise
5. Counterclockwise
6. Bottom view

9. HEAD PRESSURE CONTROL ALCO (FSY-42S)

The head pressure controller is

factory set to suit the refrigerant. It may be necessary to adjust this to suit site conditions, to raise or lower the nominal head pressure.

ALCO (FSY-42S)

- a. With the system switched off, connect a high pressure gauge to the liquid line service valve.
- b. Switch on the system, and run for a few minutes to stabilise.
- c. The head pressure should be approximately:

Min fan speed (0 rpm) and fan cut in pressure 200 psig (13.8 barg) are factory set and not adjustable.

NOTE: The condenser fan may stop if the operating pressure drops below 200 psig (13.8 barg)

R407C: 270-280 psig (18.9-19.6barg) to achieve this remove sealing plug and insert 2mm or 5/64" allen key into setting screw. Turn allen key clockwise (+) or counter clockwise (-) to readjust the setting.

Do not turn setting screw **more than 3 turns clockwise (+3)**. Use following table as a quick guideline for setting:

Pressure changes per turn of adjusting screw:

Pressure change: 9.2 ... 21.2 bar:

Clockwise ~ +2,5 bar, counter clockwise ~ -2,5 bar

After adjustment, re-insert sealing plug and make sure that it is properly fitted. IP65 protection requires firmly sealed plug

NOTES:

Tolerances for condensing temperatures setpoint: $\pm 2K$

END OF LIFE REQUIREMENTS

Refrigerant must be recovered by a certificated technician before the plant is dismantled. Modern refrigerant recovery machines should be able to remove well over 95% of the refrigerant in an old system.

All recovered HFC refrigerants can either be:

- a) Sent for destruction by incineration at a licenced waste facility
- b) Sent to a specialist plant that can re-process the old refrigerant into a gas with properties identical to virgin refrigerant, to create "reclaimed refrigerant"
- c) Given a basic cleaning process, to create "recycled refrigerant"

Given the HFC supply shortage that will be created by the phase down process, it is worth trying to send the old refrigerant for reclamation as it may have a good residual value. If the old refrigerant is too contaminated it cannot be reclaimed and must be sent for destruction. It is important not to mix different gases in the same recovery cylinder – as this would render them unsuitable for reclamation.

Reclaimed refrigerant can be used in any refrigeration equipment. Recycled refrigerant must always be used with care as it may be contaminated or of unknown composition. The use of recycled refrigerant with a GWP above 2,500 is restricted to either (a) the organisation owning the plant from which the gas was recovered or (b) the organisation that carried out the recovery.

CXE INDOOR UNIT COMPONENT IDENTIFICATION

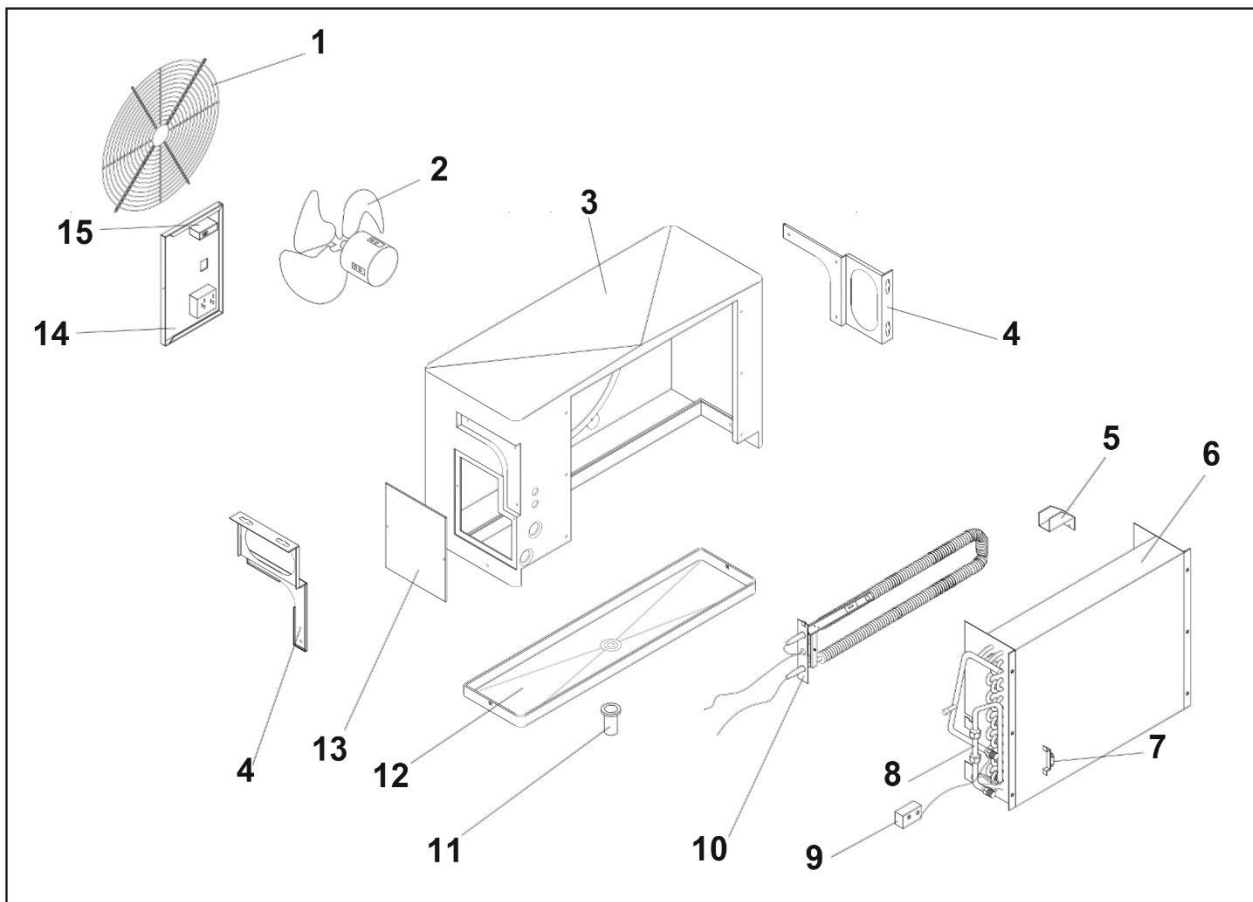

1	Grille	9	De-ice stat (option)
2	Fan / motor	10	Heater assembly (option)
3	Case	11	Drain stub adaptor
4	Wall / ceiling mounting brackets	12	Drain tray
5	Heater bracket	13	Side access panel
6	Coil assembly	14	Electrics box door
7	Thermostat bulb & bracket	15	Digital display (option)
8	Restrictor assembly / extended pipe (option)		

INSIDE VIEW OF ELECTRICS BOX

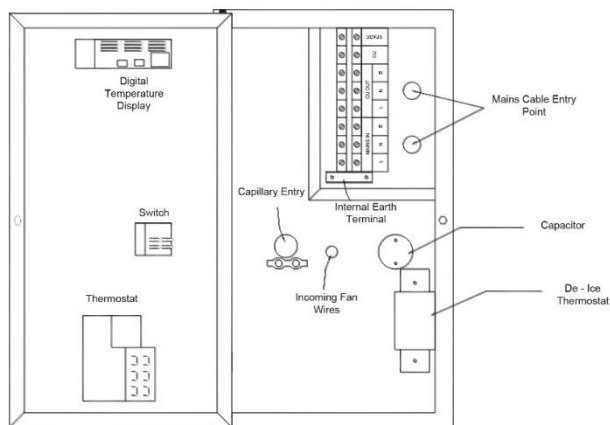

CKC OUTDOOR UNIT COMPONENT IDENTIFICATION

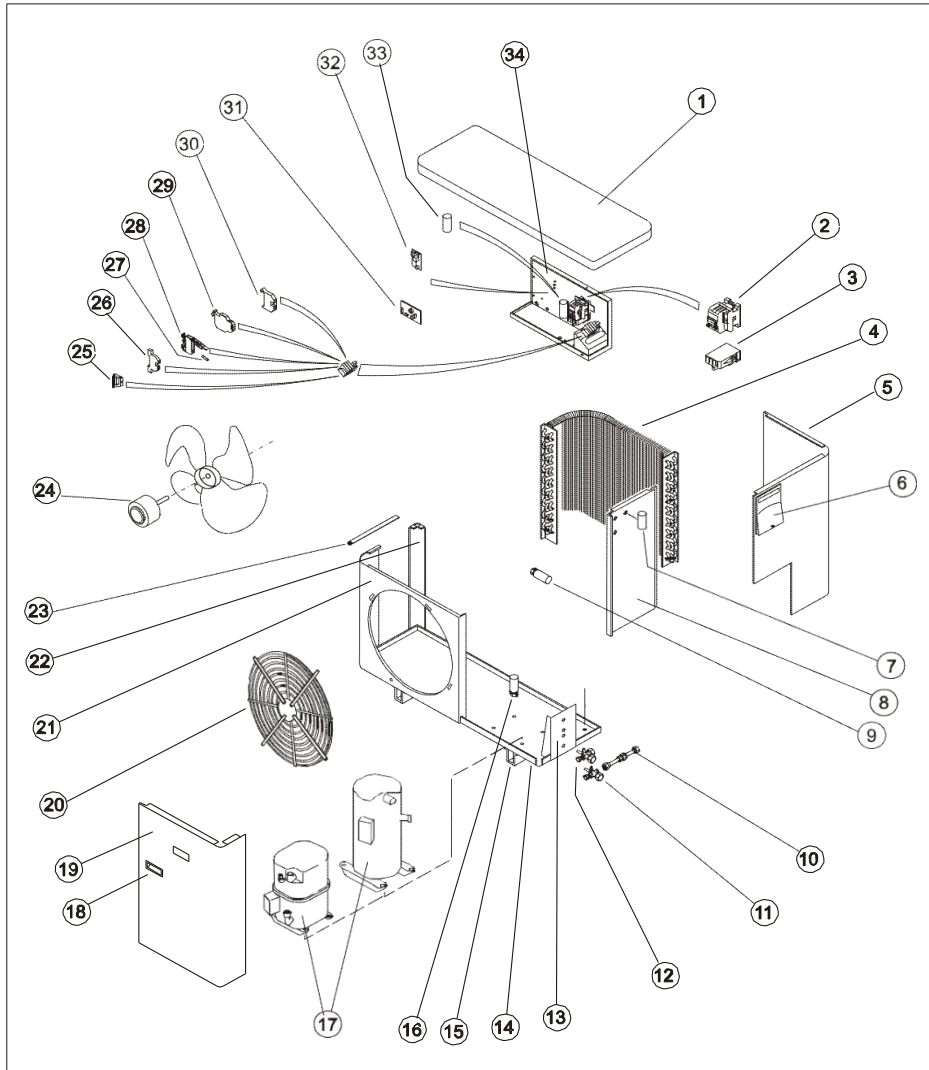

1	LID	18	HANDLE
2	CONTACTOR	19	FRONT ACCESS
3	OVERLOAD	20	FAN GUARD
4	HEAT EXCHANGER COIL	21	FASCIA PANEL
5	REAR ACCESS PANEL	22	CORNER PANEL
6	MAINS TERMINAL COVER	23	SUPPORT BRACKET
7	FAN CAPACITOR	24	FAN / MOTOR ASSEMBLY
8	BULKHEAD PANEL	25	END CLAMP
9	HP SWITCH (MANUAL, OPTION)	26	TERMINAL
10	EXPANSION ASSEMBLY	27	FUSE
11	SERVICE VALVE (LIQUID)	28	FUSE TERMINAL
12	SERVICE VALVE (SUCTION)	29	TERMINAL (4 WAY)
13	VALVE PANEL	30	EARTH TERMINAL
14	BASE	31	HEAD PRESSURE CONTROL pcb
15	MOUNTING FOOT	32	3 MINUTE TIMER pcb
16	LP SWITCH	33	COMPRESSOR CAPACITOR
17	COMPRESSOR	34	ELECTRICS BOX