

MARSTAIR

REFRIGERATION AND SPECIALIST AIR CONDITIONING

PRODUCT RANGE

EURO PRICE LIST JULY 2021

PROCESS/MATERIAL COOLING • CLOSE CONTROL • REFRIGERATION

refrigeration & specialist air conditioning

In partnership with

QUARTZ

FAN COILS AND HVAC



DESIGNED
& BUILT
IN THE UK

WWW.MARSTAIR.COM

CONTENTS

Direct Expansion

Air Purification

- 3 Shield Built-In Virus Protection

Air Conditioning

Process/Material Cooling

- 4 DXT Wall and Ceiling Mounted Units
- 6 WM Wall Mounted Units - high wall mounted with high level front air discharge
- 7 DXD
- 8 600 Ceiling Cassettes - to suit standard 600 x 600mm ceiling tile grid
- 9 875 Ceiling Cassettes
- 10 CKC - matching Outdoor Condensing Units
- 11 DCU+ - Ducted Condensing Units

Close Control

- 12 CD3 - Configurable, Packaged and Chilled Water Units

Refrigeration

- 19 CX(E) Cellarator, CXA, Multi-Split Systems
- 23 A2LcellarMatch
- 24 CC600 & CC875 Low Temperature Cassettes
- 26 Wine Cellar Coolers - WM Wall Mounted & DXD Ducted Units
- 29 Low Temperature Air Conditioning - DXT Wall Mounted Units
- 33 MRC(+) & Eskimo Condensing Units
- 35 A2LsystemMatch
- 37 DRC+ - Ducted Medium Temperature Condensing Units
- 38 MB & MW - Cold Room Evaporators
- 40 CO2 Evaporators

Marine

- 45 Marine Options
- 47 ATEX & Offshore

All prices quoted are ex-works and subject to VAT

SHIELD - BUILT-IN VIRUS PROTECTION

Minislim Shield - Built-In Virus Protection



Description		Part Number	Price
Minislim Unit Bi-Polar Marstair	Standard mini with BPI	TOPAZ 05BP MAR	POA
FFO Mini-Slim BPI Mobile Marstair	Back panel and feet added & Plug	56702003	POA

FFO DXT Ioniser Assembly Marstair	Fitted to DXT Units	56702002	POA
FFO Marstair Shield	Ioniser into marstair unit	56702004	POA

Description		Part Number	Price
Shield BPI Easy Fit Marstair	with No DP Switch	56702000	POA
Shield BPI Easy Fit + DP Switch Marstair	with DP Switch	56702001	POA

EVAPORATORS



DXT

Wall Mounted Unit (Ceiling Mounted Option) - **Cased Units**

DXT EVAPORATOR CASED UNIT

INDOOR UNIT				
MODEL NO	PART NO.	TOTAL COOLING kW	TOTAL SENSIBLE COOLING kW	PRICE (€)
2*	5670002*	1.5	1.5	1486
4*	5670004*	2.3	2.3	1638
6*	5670006*	3.3	3.3	1759
7*	5670007*	3.9	3.9	1901
9*	5670009*	5.7	5.7	2053
10*	5670010*	6.3	6.3	2930
12*	5670012*	8.0	8.0	3313

For Version 6 Models

INDOOR UNIT				
MODEL NO	PART NO.	TOTAL COOLING kW	TOTAL SENSIBLE COOLING kW	PRICE (€)
10*	56700106*	6.3	6.3	4263
12*	56700126*	8.0	8.0	4557

*Cooling capacities based on 21°C air on, R407C 2.5°C evaporating and maximum speed
*See diagram for cased unit number ending in 0, 5, 6, 8, 1, 4, 9.

Vertical Cased Units

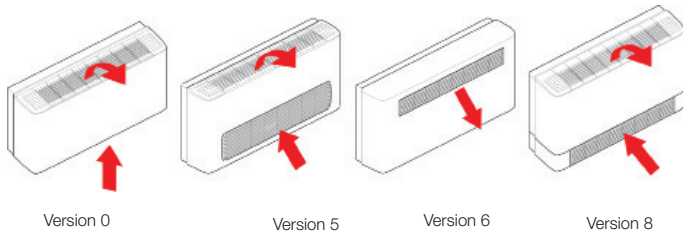

Horizontal Cased Units

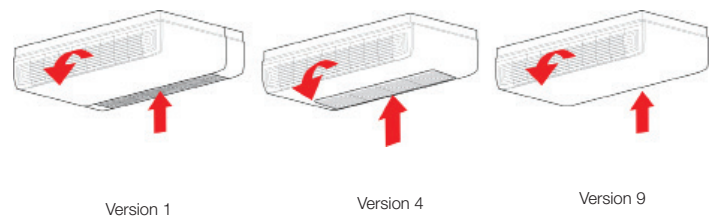

Indoor Unit Accessories

DESCRIPTION	DXT	PART NO.	PRICE (€)	
Electric Heater Case 0-5-8	0.6 kW	10	40906086	365
	1.0 kW	20	40906087	365
	1.0 kW	40	40906088	390
	2.0 kW	60	40906090	415
	2.0 kW	70	40906091	415
	3.0 kW	90	40906092	430
	3.0 kW	100	40906093	820
	4.5 kW	120	40906096	840
Electric Heater Case 1-4-9	0.6 kW	10	40906097	365
	1.0 kW	20	40906098	365
	1.0 kW	40	40906099	390
	2.0 kW	60	40906100	415
	2.0 kW	70	40906101	415
	3.0 kW	90	40906102	430
	3.0 kW	100	40906103	820
	4.5 kW	120	40906106	840

DESCRIPTION	DXT	PART NO.	PRICE (€)	
Condensate Pump	Horizontal	10 - 60	40905016	935
	Horizontal	70 - 120	40905017	935
	Vertical	10 - 60	40905018	935
	Vertical	70 - 120	40905019	935
Fitted TEV		N/A	POA	
RDG 100	ALL	485233	155	
Thermostat with Dial (RCC 30)	ALL	97200211	160	
Thermostat with Timer (RDG 100T)	ALL	485229	255	
Return Air Sensor Kit	ALL	97200212	110	
Volt Free Relay	240V	ALL	48000410	125
Volt Free Relay	24V	ALL	48000411	125
Master Slave Box	ALL	55600414	300	

* Fitted as standard ** Option

* Fitted as standard ** Option

EVAPORATORS

DXT

Wall Mounted Unit (Ceiling Mounted Option) - Chassis Units



DXT EVAPORATOR CHASSIS UNIT

INDOOR UNIT				
MODEL NO	PART NO.	TOTAL COOLING kW	TOTAL SENSIBLE COOLING kW	PRICE (€)
2*	5670002*	1.5	1.5	1239
4*	5670004*	2.3	2.3	1239
6*	5670006*	3.3	3.3	1470
7*	5670007*	3.9	3.9	1596
9*	5670009*	5.7	5.7	1801
10*	5670010*	6.3	6.3	2457
12*	5670012*	8.0	8.0	2751

*Cooling capacities based on 21°C air on, R407C 2.5°C evaporating and maximum speed

* See diagram for chassis unit number ending in 2, 3, & 7.

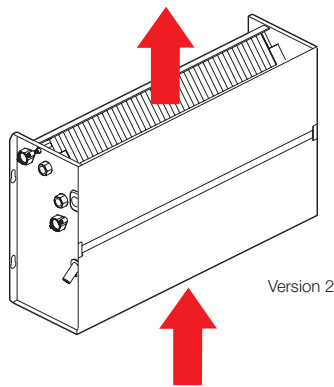

Vertical Chassis Units

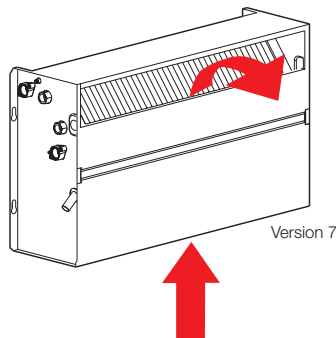

Horizontal Chassis Units

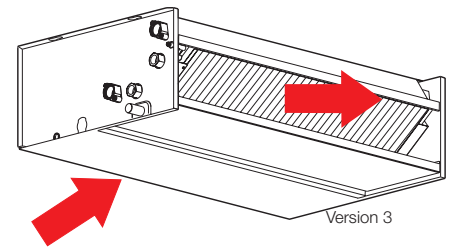

Indoor Unit Accessories

DESCRIPTION	DXT	PART NO.	PRICE (€)	
Electric Heater	0.6 kW	10	40906107	365
	1.0 kW	20	40906108	365
	1.0 kW	40	40906109	390
	2.0 kW	60	40906110	415
	2.0 kW	70	40906111	415
	3.0 kW	90	40906112	430
	3.0 kW	100	40906113	820
	4.5 kW	120	40906116	840
Condensate Pump	Horizontal	10 - 60	40905016	935
	Horizontal	70 - 120	40905017	935
	Vertical	10 - 60	40905018	935
	Vertical	70 - 120	40905019	935

DESCRIPTION	DXT	PART NO.	PRICE (€)	
Fitted TEV		N/A	POA	
RDG 100	ALL	485233	155	
Thermostat with Dial (RCC 30)	ALL	97200211	160	
Thermostat with Timer (RDG 100T)	ALL	485229	255	
Return Air Sensor Kit	ALL	97200212	110	
Volt Free Relay	240V	ALL	48000410	125
Volt Free Relay	24V	ALL	48000411	125
Master Slave Box	ALL	55600414	300	

* Fitted as standard ** Option

* Fitted as standard ** Option

EVAPORATORS

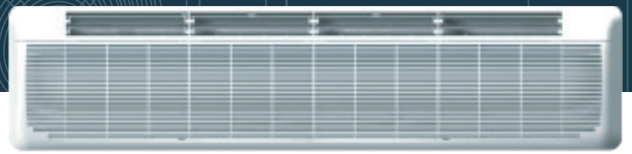

Wall Mounted WM High Wall Mounted Unit

WM EVAPORATOR
WIRED CONTROL INDOOR UNIT

INDOOR UNIT						
MODEL NO	PART NO.	TOTAL COOLING kW	TOTAL SENSIBLE COOLING		HEATING kW	PRICE (€)
			kW	SHR		
60	55600001	3.8	2.9	0.76	*	1446
80	55600002	5.3	4.1	0.77	*	1642
100	55600003	6.8	5.3	0.78	*	1884

*Electric Heating Available - See Accessories.

Indoor Unit Accessories

DESCRIPTION	WM	WM 'E'	PART NO.	PRICE (€)	
Electric Heater	1.3kW	60	-	55600401	275
	1.8kW	80	-	55600402	295
	2.3kW	100	-	55600403	320
Electric Heater/ Heat Pump Boost Heater	1.3kW	-	60	55600411	265
	1.8kW	-	80	55600412	265
	2.3kW	-	100	55600413	295
Pipe Exit Kit	60	60	55600425	70	
	80 - 100	80 - 100	55600426	75	
Condensate Pump (5m head - with flow protection)	ALL	ALL	97300446	225	
Programmable Timer	ALL	-	52500151	160	
Return Air Sensor Kit	ALL	-	97200212	110	
Master Slave Box	ALL	-	55600414	300	
BMS Alarm Interface	-	ALL	53800423	90	

Cooling capacities based on 21°C air on, R407C 2.5°C evaporating and maximum speed
Heating capacities based on 18°C air on, R407C 40°C condensing and maximum speed

NB: All accessories are field fit kits

For factory fitted accessories please contact Marstair on **01484 405666**

EVAPORATORS

DXD

Concealed Ducted Units

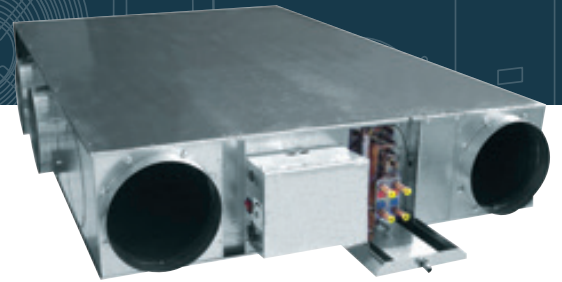

DXD(H) HEAT PUMPS
WIRED CONTROL INDOOR UNIT

INDOOR UNIT						
MODEL NO	PART NO.	TOTAL COOLING kW	TOTAL SENSIBLE COOLING		HEATING kW	PRICE (€)
			kW	SHR		
50	56600021	3.7	2.7	0.73	4.1	2273
60	56600022	4.7	3.3	0.70	4.8	2495
90	56600024	8.2	5.9	0.72	8.9	2948
130	56600026	9.6	7.0	0.73	10.5	3855
150	56600027	11.8	8.5	0.72	12.7	4082

*Electric Heating Available - See Accessories.

Cooling capacities based on 21°C air on, R407C 2.5°C evaporating and maximum speed

Heating capacities based on 18°C air on, R407C 40°C condensing and maximum speed

Indoor Unit Accessories

DESCRIPTION		DXD	PART NO.	PRICE (€)
FFO Electric Heater	2.0kW	50 - 60	56600406	335
FFO Electric Heater	2.0kW	90	56600407	430
FFO Electric Heater	3.0kW	130	56600408	505
FFO Electric Heater	4.0kW	150	56600409	595
FFO Boost Heater	2.0kW	50 - 60 (H)	56600415	390
FFO Boost Heater	2.0kW	90 (H)	56600416	460
FFO Boost Heater	3.0kW	130 (H)	56600417	545
FFO Boost Heater	4.0kW	150 (H)	56600418	580
FFO Return Air Plenum 50		50	56600401	300
FFO Return Air Plenum 60		60	56600402	320
FFO Return Air Plenum 90		90	56600403	370
FFO Return Air Plenum 130		130	56600404	410
FFO Return Air Plenum 150		150	56600405	445
Discharge/Inlet Spigot *	200mm dia	ALL	48002094S	60
	250mm dia	ALL	48001985S	40
FFO LPHW Coil		50 RH	48023048	270
FFO LPHW Coil		60 RH	48023050	300
FFO LPHW Coil		90 RH	48023052	410
FFO LPHW Coil		130 RH	48023054	465
FFO LPHW Coil		150 RH	48023056	525
Return Air Sensor Kit		ALL	97200212	110
Condensate Pump Kit		ALL	48030058	220
Programmable Timer Kit		ALL	52500151	160
Master Slave Box		ALL	55600414	300

EVAPORATORS

CC600 Ceiling Cassette 600x600 Ceiling Cassette



CC600 EVAPORATOR UNIT
WIRED CONTROL INDOOR UNIT WITH 5M CONDENSATE PUMP

MODEL NO	PART NO.	TOTAL COOLING kW	INDOOR UNIT				FASCIA		
			TOTAL SENSIBLE COOLING		HEATING kW	PRICE (€)	PART NO.	PRICE (€)	TOTAL PRICE (€)
			kW	SHR					
20	55222004	1.9	1.6	0.84	*	1651	55222000	311	1962
40	55222005	3.3	2.6	0.79	*	1776	55222000	311	2087
60	55222006	4.3	3.2	0.74	*	1920	55222000	311	2231

*Electric Heating Available - See Accessories.



CC600 Ceiling Cassette
Wired Controller

Indoor Unit Accessories

DESCRIPTION	CC600	PART NO.	PRICE (€)
Electric Heater	1.0kW	ALL	55200317 295
	2.0kW	ALL	55200313 355
Motorised Vanes for heating mode	ALL	97100312	270
Return Air Sensor Kit	ALL	97200212	110
Fresh Air Inlet Spigot 100mm dia	ALL	55200305	90
Branch Duct Spigot 100mm dia	ALL	55200306	140
Programmable Timer	ALL	52500151	105
Discharge Blanking Kit (for 3 way discharge)	ALL	55500316	160
Master Slave Box	ALL	55600414	40
			300

NB: All accessories are field fit kits
For factory fitted accessories please contact Marstair on **01484 405666**

EVAPORATORS

CC875 Ceiling Cassette 875x875 Ceiling Cassette



CC875 EVAPORATOR UNIT
WIRED CONTROL INDOOR UNIT WITH 5M CONDENSATE PUMP

MODEL NO	PART NO.	TOTAL COOLING kW	INDOOR UNIT				FASCIA		
			TOTAL SENSIBLE COOLING		HEATING kW	PRICE (€)	PART NO.	PRICE (€)	TOTAL PRICE (€)
			kW	SHR					
80	55522135	6.4	5.1	0.80	*	2489	55522000	404	2893
110	55522136	8.2	6.3	0.77	*	2680	55522000	404	3084
140	55522137	9.4	6.9	0.73	*	2839	55522000	404	3243

*Electric Heating Available - See Accessories.



CC875 Ceiling Cassette
Wired Controller

Indoor Unit Accessories

DESCRIPTION	CC875	PART NO.	PRICE (€)
Electric Heater	1.0kW	ALL	55500311 355
	2.0kW	ALL	55500312 440
	3.0kW	ALL	55500313 495
	4.0kW 3Ph	ALL	55500314 585
Return Air Sensor Kit	ALL	97200212	110
Branch Duct Spigot 150mm dia	ALL	55500304	210
Fresh Air Inlet Spigot 100mm dia	ALL	55200305	140
Programmable Timer	ALL	52500151	160
Discharge Blanking Kit (for 3 way discharge)	ALL	55500316	40
Master Slave Box	ALL	55600414	300

NB: All accessories are field fit kits
For factory fitted accessories please contact Marstair on **01484 405666**

CONDENSERS

CKC

Condensing Units - R407C



OUTDOOR UNIT										
Model No	Nominal Cooling Duty kW	Single Phase (1ph) Part No.	Compressor Type	Price (€)	Three Phase (3ph) Part No.	Compressor Type	Price (€)	Expansion Device Part No.	Price (€)	
CKC	15	2.5	55050769	reciprocating	1529	-	-	-	55023323	150
	20	2.8	55050720	reciprocating	1645	-	-	-	55023323	150
	30	3.7	55050730	reciprocating	1678	55050774	reciprocating	2123	55023324	150
	40	4.2	55050741	reciprocating	1942	55050775	reciprocating	2327	55023325	150
	50	5.8	55050722	scroll	2096	55050776	scroll	2492	55023327	150
	60	7.0	55050740	scroll	2162	55050777	scroll	2602	55023328	150
	80	7.4	55050723	scroll	2409	55050724	scroll	2475	55023329	150
	90	8.2	55050771	scroll	3317	55050778	scroll	3465	55023330	150
	100	10.9	-	-	-	55050779	scroll	3911	55023331	150
	130	12.4	-	-	-	55020780	scroll	4301	55023332	150
	150	13.8	-	-	-	55020781	scroll	4593	55023333	150
	165	14.7	-	-	-	55020782	scroll	6259	55023334	150
	180	17.1	-	-	-	55020783	scroll	5489	55023335	150
200	19.9	-	-	-	55020784	scroll	7464	-	-	

Expansion device not required when matched with cellar coolers or CD3 close control evaporators

Nominal Capacities quoted at 7.5°C saturated suction temperature and 35°C air on the condensing unit

*All models up to 80m except models 15 and 20 which are up to 50m, equivalent length

Outdoor Unit Accessories

DESCRIPTION	CKC	PART NO.	PRICE (€)	
Wall Mounting Brackets	15-80	55021100	90	
	90-200	55021101	125	
Pressure Switch	HP (Manual with alarm output)	ALL	55000398	205
Volt Free Relay (including HP switch with alarm output)		ALL	55000395	225
Overload for 1 Phase	15	55023316	140	
	20	55023317	140	
	30 - 80	55023318	150	
	90	55023319	170	
PTC - (hard start 1 phase only recip)		15-40	55000412	90
CSR - (hard start 1 phase only recip)		15, 20, 30, 40,	55000414	140
Isolator (unit mounted) for local isolation	1 phase	15-60	55023220	170
	3 phase	80-90	55023221	260
Compressor Jacket	ALL	55023222	200	
	15-40	55000454	130	
	50-100	55000455	140	
	130-180	55000456	155	
Kit Panel Insulation	200	55000457	180	
	15-40	55021800	90	
	50-80	55021801	100	
	90-100	55021802	110	
R134a Pressure Switch Kit	130-165	55021803	125	
	180-200	55021804	180	
R134a Pressure Switch Kit		ALL	55023322	195

CONDENSERS

DCU+ Ducted Condensing Units



DCU+ DUCTED CONDENSING UNITS - R407C

CONDENSING UNIT										
Model No	Nominal Cooling Duty kW	Single Phase (1ph) Part No.	Compressor Type	Price(€)	Three Phase (3ph) Part No.	Compressor Type	Price (€)	Expansion device Part No.	Price (€)	
DCU+	15	2.6	54224027	reciprocating*	2851	-	-	-	55023337	150
	20	2.8	54224028	reciprocating*	2952	-	-	-	55023338	150
	30	3.7	54224029	reciprocating	3259	54224035	reciprocating	3327	55023339	150
	40	4.6	54224030	reciprocating	3338	54224036	reciprocating	3477	55023340	150
	50	5.8	54224031	reciprocating	3729	54224037	reciprocating	3858	55023326	150
	60	6.3	54224032	reciprocating	4411	54224038	reciprocating	4545	55023327	150
	80	6.9	54224033	reciprocating	4590	54224039	reciprocating	4724	55023341	150

Nominal capacities quoted at 7.5°C saturated suction temperature and 35°C air on the condensing unit

*All models up to 80m except models 15 and 20 (up to 50m), equivalent length pipe run.

Outdoor Unit Accessories

DESCRIPTION	DCU+	DHPUE	PART NO.	PRICE(€)
Wall Mounting Kit	ALL	ALL	53200407	115
Volt Free Relay (including HP switch with alarm output)	ALL	ALL	55000395	225
PTC - (hard start 1 phase only)	ALL	ALL	54000407	90
CSR - (hard start 1 phase only)	15-20	15	54000403	155
	30	30	54000404	140
	40	40	54000403	155
	50	50	54000405	150
	60-80	60	54000406	200
Overload for 1 Phase (standard on 3 phase)	15-20	15	55023316	140
	30-40	20	55023317	140
	50-80	30-50	55023318	150
	60-80	60	55023319	170
Condensate Pump Kit	-	ALL	54300452	355
Mains Isolator	ALL	ALL	54200451	130

NB: All accessories are field fit kits

For factory fitted accessories please contact Marstair on **01484 405666**

CLOSE CONTROL

CD3 DX Packaged

CD3 COOLING SYSTEMS (UPFLOW) - Package - Twin Circuit



AIR HANDLING UNIT								CONDENSING UNITS			SYSTEM
Model No	Part No.	System Cooling Total kW	SHR	Air Flow m³/s	Cooling Circuits*	Electric Heating kW	Price (€)	Model No	Three Phase (3ph) Part No.	Price (€)	3ph Price (€)
008	92918001	7.4	1.00	0.778	2	8	11343	CKC 30	55050774	2123	15589
								DCU+ 30	54224035	3327	17997
008	92918001	10.3	0.87	0.778	2	8	11343	CKC 50	55050776	2492	16327
								DCU+ 50	54224037	3858	19059
010	92918002	11.0	0.97	1.038	2	10	12544	CKC 50	55050776	2492	17528
								DCU+ 50	54224037	3858	20260
010	92918002	11.8	0.93	1.038	2	10	12544	CKC 60	55050777	2602	17748
								DCU+ 60	54224038	4545	21634
015	92918003	13.8	0.97	1.225	2	16	13772	CKC 80	55050724	2475	18722
								DCU+ 80	54224039	4724	23220
015	92918003	18.7	0.83	1.225	2	16	13772	CKC 100	55050779	3911	21594
020	92918004	18.0	0.94	1.510	2	20	16271	CKC 90	55050778	3465	23201
020	92918004	21.9	0.85	1.510	2	20	16271	CKC 130	55020780	4301	24873

* 2 Cooling Circuit systems require 2 condensing units

CD3 COOLING SYSTEMS (UPFLOW) - Package - Single Circuit (Add Single Circuit Pipework Conversion Kit)**

AIR HANDLING UNIT (3ph)								CONDENSING UNITS			SYSTEM
Model No	Part No.	System Cooling Total kW	SHR	Air Flow m³/s	Cooling Circuits**	Electric Heating kW	Price (€)	Model No	Three Phase (3ph) Part No.	Price (€)	3ph Price (€)
008	92918001	7.4	1.00	0.778	1	8	11343	CKC 80	55050724	2475	13818
								DCU+ 80	54224039	4724	16067
008	92918001	10.3	0.87	0.778	1	8	11343	CKC 100	55050779	3911	15254
010	92918002	11.0	0.97	1.038	1	10	12544	CKC 100	55050779	3911	16455
010	92918002	11.8	0.93	1.038	1	10	12544	CKC 130	55020780	4301	16845
015	92918003	13.8	0.97	1.225	1	16	13772	CKC 165	55020782	6259	20031
015	92918003	18.7	0.83	1.225	1	16	13772	CKC 180	55020783	5489	19261
020	92918004	18.0	0.94	1.510	1	20	16271	CKC 180	55020783	5489	21760
020	92918004	21.9	0.85	1.510	1	20	16271	CKC 200	55020784	7464	23735

**1 Cooling Circuit systems require Single Pipework Conversion Kit

Cooling Conditions @ high fan speed indoor unit with 7.5m pipe run
Room 21°C db/15°C wb Ambient 35°C. Electric heaters rated at 240V

Field Fit Kits

DESCRIPTION	MODEL	PART NO.	PRICE (€)	
Condensate Pump complete with high water alarm	(Hot & Cold, 5m head)	All Models	92919077	620
Fresh Air Spigot For use with fan and filter	100mm dia	All Models	92911062	315
	160mm dia	All Models	92911063	320
Fresh Air Fan and Filter	93m³/h	All Models	92911003	260
	186m³/h	All Models	92911004	635
Disposable Filter (BS EN 779 G3) - 50mm (Replaces washable filter)	8		92911038	150
	010, 015		92911039	150
	20		92911040	160
Kit Common Alarm & Volt Freeze Contact	(Hot & Cold, 5m head)	All Models	92911006	305

DESCRIPTION	MODEL	PART NO.	PRICE (€)
Floor Stand Plinth 75mm high	8	92911032	400
	010, 015	92911033	415
	20	92911034	440
Top Ducted Discharge Spigot	008	92911059	190
	010, 015	92911060	200
	20	92911061	210
Double Deflection Grille	008	92911094	305
	010, 015	92911095	320
	20	92911096	370

Factory Fit Options

DESCRIPTION	MODEL	PART NO.	PRICE (€)
**Single Circuit Pipework Conversion Kit	008	92911102	200
	10	92911103	200
	15	92911104	200
	020	92911105	285

Cooling Conditions @ high fan speed indoor unit with 7.5m pipe run
Room 21°C db/15°C wb Ambient 35°C. Electric heaters rated at 240V

CD3

DX Basic Configurable Units



CD3 COOLING SYSTEMS (DOWNFLOW)

AIR HANDLING UNIT (3ph)								CONDENSING UNITS				SYSTEM		
Model No	Part No.	System Cooling Total kW	SHR	Air Flow m ³ /s	Cooling Circuits†	Electric ‡ Heating kW	Price (€)	Model No	Single Phase (1ph)* Part No.	Price (€)	Three Phase (3ph) Part No.	Price (€)	1ph Price (€)	3ph Price (€)
008	92918014	7.2	1.00	0.778	1	8	7316	CKC 80	55023723	2255	55050724	2475	9571	9791
								DCU+ 80	54224033	4590	54224039	4724	11906	12040
008	92918015	7.4	1.00	0.778	2	8	7450	CKC 30	55023730	1678	55050774	2123	10806	11696
								DCU+ 30	54224029	3259	54224035	3327	13968	14104
008	92918014	10.0	0.89	0.778	1	8	7316	CKC 100	-	-	55050779	3911	-	11227
008	92918015	10.5	0.87	0.778	2	8	7450	CKC 50	55023722	1958	55050776	2492	11366	12434
								DCU+ 50	54224031	3729	54224037	3858	14908	15166
010	92918016	10.6	0.99	1.038	1	10	7834	CKC 100	-	-	55050779	3911	-	11745
010	92918017	11.0	0.97	1.038	2	10	8678	CKC 50	55023722	1958	55050776	2492	12594	13662
								DCU+ 50	54224031	3729	54224037	3858	16136	16394
010	92918016	12.0	0.93	1.038	1	10	7834	CKC 130	-	-	55020780	4301	-	12135
010	92918017	12.1	0.93	1.038	2	10	8978	CKC 60	55023740	2019	55050777	2602	12716	13882
								DCU+ 60	54224032	4411	54224038	4545	17500	17768
015	92918018	14.8	0.94	1.225	1	16	8715	CKC 165	-	-	55020782	6259	-	14974
015	92918019	13.8	0.97	1.225	2	16	9543	CKC 80	55023723	2255	55050724	2475	14053	14493
								DCU+ 80	54224033	4590	54224039	4724	18723	18991
015	92918018	16.4	0.98	1.225	1	16	8715	CKC 180	-	-	55020783	5489	-	14204
015	92918019	19.2	0.83	1.225	2	16	9543	CKC 100	-	-	55050779	3911	-	17365
020	92918020	16.8	0.98	1.510	1	20	9725	CKC 180	-	-	55020783	5489	-	15214
020	92918021	18.1	0.94	1.510	2	20	11957	CKC 90	55023771	3152	55050778	3465	18261	18887
020	92918020	19.5	0.91	1.510	1	20	9725	CKC 200	-	-	55020784	7464	-	17189
020	92918021	22.4	0.85	1.510	2	20	11957	CKC 130	-	-	55020780	4301	-	20559

† 2 Cooling Circuit systems require 2 condensing units

‡ Maximum Heater Load - See accessories for additional costs

* When using 1 phase condensing units please order indoor unit conversion kit

CKC Outdoor Unit Field Fit Kits

DESCRIPTION	MCU+	PART NO.	PRICE (€)	
Wall Mounting Brackets	15-80	55021100	90	
	90-200	55021101	125	
Pressure Switch HP (Manual with alarm output)	ALL	55000398	205	
Volt Free Relay (including HP switch with alarm output)	ALL	55000395	225	
	30 - 40	55023234	140	
	50 - 80	55023235	150	
	90	55023247	170	
Isolator	1 phase	15-60	55023220	170
		80-90	55023221	260
	3 phase	ALL	55023222	200

DESCRIPTION	CKC	PART NO.	PRICE (€)
Compressor Jacket	15-40	55000454	130
	50-100	55000455	140
	130-180	55000456	155
	200	55000457	180
Kit Panel Insulation	15-40	55021800	90
	50-80	55021801	100
	90-100	55021802	110
	130-165	55021803	125
	180-200	55021804	180
R134a Pressure Switch Kit	ALL	55023322	90

NB: All accessories are field fit kits

For factory fitted accessories please contact Marstair on **01484 405666**

CD3

DX Basic Configurable Units



CD3 COOLING SYSTEMS (UPFLOW)

AIR HANDLING UNIT (3ph)								CONDENSING UNITS				SYSTEM		
Model No	Part No.	System Cooling Total kW	SHR	Air Flow m ³ /s	Cooling Circuits†	Electric ‡ Heating kW	Price (€)	Model No	Single Phase (1ph)* Part No.	Price (€)	Three Phase (3ph) Part No.	Price (€)	1ph Price (€)	3ph Price (€)
008	92918006	7.2	1.00	0.778	1	8	7525	CKC 80	55050723	2409	55050724	2475	9934	10000
								DCU+ 80	54224033	4590	54224039	4724	12115	12249
008	92918007	7.4	1.00	0.778	2	8	7599	CKC 30	55050730	1678	55050774	2123	10955	11845
								DCU+ 30	54224029	3259	54224035	3327	14117	14253
008	92918006	10.0	0.89	0.778	1	8	7525	CKC 100	-	-	55050779	3911	-	11436
008	92918007	10.3	0.87	0.778	2	8	7599	CKC 50	55050722	2096	55050776	2492	11791	12583
								DCU+ 50	54224031	3729	54224037	3858	15057	15315
010	92918008	10.6	0.99	1.038	1	10	8043	CKC 100	-	-	55050779	3911	-	11954
010	92918009	11.0	0.97	1.038	2	10	8844	CKC 50	55050722	2096	55050776	2492	13036	13828
								DCU+ 50	54224031	3729	54224037	3858	16302	16560
010	92918008	12.0	0.93	1.038	1	10	8043	CKC 130	-	-	55020780	4301	-	12344
010	92918009	12.1	0.93	1.038	2	10	8844	CKC 60	55050740	2162	55050777	2602	13168	14048
								DCU+ 60	54224032	4411	54224038	4545	17666	17934
015	92918010	14.8	0.94	1.225	1	16	8945	CKC 165	-	-	55020782	6259	-	15204
015	92918011	13.8	0.97	1.225	2	16	9591	CKC 80	55050723	2409	55050724	2475	14409	14541
								DCU+ 80	54224033	4590	54224039	4724	18771	19039
015	92918010	16.4	0.98	1.225	1	16	8945	CKC 180	-	-	55020783	5489	-	14434
015	92918011	19.2	0.83	1.225	2	16	9591	CKC 100	-	-	55050779	3911	-	17413
020	92918012	16.8	0.98	1.510	1	20	9981	CKC 180	-	-	55020783	5489	-	15470
020	92918013	18.1	0.94	1.510	2	20	12213	CKC 90	55050771	3317	55050778	3465	18847	19143
020	92918012	19.5	0.91	1.510	1	20	9981	CKC 200	-	-	55020784	7464	-	17445
020	92918013	22.4	0.85	1.510	2	20	12213	CKC 130	-	-	55020780	4301	-	20815

† 2 Cooling Circuit systems require 2 condensing units

‡ Maximum Heater Load - See accessories for additional costs

* When using 1 phase condensing units please order indoor unit conversion kit

Cooling Conditions @ high fan speed indoor unit with 7.5m pipe run Room 21°C db/15°C wb Ambient 35°C
Electric heaters rated at 240V

DCU+ Outdoor Unit Field Fit Kits

DESCRIPTION	DCU+	PART NO.	PRICE (€)
Wall Mounting Kit	ALL	53200407	115
Volt Free Relay (inc HP switch with alarm output)	ALL	55000395	225
PTC - (hard start 1 phase only)	ALL	54000407	90
CSR - (hard start 1 phase only)	15-20	54000403	155
	30	54000404	140
	40	54000403	155
	50	54000405	150
	60-80	54000406	200
Overload for 1 Phase (standard on 3 phase)	15-20	55023316	140
	30-40	55023317	140
	50-80	55023318	150

DESCRIPTION	DCU+	PART NO.	PRICE (€)	
Condensate Pump Kit	-	54300452	355	
Mains Isolator	ALL	54200451	130	
Insulated Ducting (5m)	355mm Dia	15-40	53200402	450
	406mm Dia	50-80	53200403	460
Duct Transition Piece (each) (to suit grille)	15-40	53200405	530	
	50-80	53200406	530	
Grille (each)	15-40	53200420	300	
	50-80	53200421	315	

NB: All accessories are field fit kits

All units require 2 Duct Transition Pieces and 2 Grilles

For factory fitted accessories please contact Marstair on **01484 405666**

CD3

Chilled Water Basic Configurable Unit



CD3 COOLING SYSTEMS (UPFLOW)

AIR HANDLING UNIT (3ph)								
Model No	Part No.	LOW SPEED System cooling Total kW	SHR	Air flow m³/s	HIGH SPEED System cooling Total kW	SHR	Air flow m³/s	Price (€)
008	92917001	5.1	0.95	0.420	8.2	0.99	0.778	7172
010	92917002	8.7	0.90	0.670	11.5	0.96	1.038	7770
015	92917003	10.8	0.87	0.717	15.6	0.92	1.225	8801
020	92917004	14.8	0.84	0.924	20.4	0.89	1.510	9981

CD3 COOLING SYSTEMS (DOWNFLOW)

AIR HANDLING UNIT (3ph)								
Model No	Part No.	LOW SPEED System cooling Total kW	SHR	Air flow m³/s	HIGH SPEED System cooling Total kW	SHR	Air flow m³/s	Price (€)
008	92917005	5.1	0.95	0.420	8.2	0.99	0.778	6975
010	92917006	8.7	0.90	0.670	11.5	0.96	1.038	7594
015	92917007	10.8	0.87	0.717	15.6	0.92	1.225	8715
020	92917008	14.8	0.84	0.924	20.4	0.89	1.510	9725

Cooling Conditions @ high fan speed indoor unit with Room 22°C db/15.42°C wb Water flow return/return temps 6/11°C
Electric heaters rated at 240V

CD3

Configurable Factory Fitted Options



DESCRIPTION	MODEL	DX CONFIGURED	CHILLED WATER CONFIGURED	FACTORY FITTED PART NO.	PRICE (€)	
FFO Thermostatic Expansion Valves	008/1	Option	N/A	92900468	330	
	010/1	Option	N/A	92900469	330	
	015/1	Option	N/A	92900470	555	
	020/1	Option	N/A	92900471	565	
	008/2	Option	N/A	92900472	565	
	010/2	Option	N/A	92900516	610	
	015/2	Option	N/A	92900473	610	
	020/2	Option	N/A	92900474	610	
FFO Electric Heaters (also see heater rail) Single Stage Upflow (For 2 Stage Heaters add kits together, i.e. 8kW+8kW=16kW) Max Heater Loads 008=8kW, 010=10kW, 015=16kW, 020=20kW	2 kW	Option	Option	92919001	305	
	4 kW	Option	Option	92919002	415	
	6 kW	Option	Option	92919003	545	
	8 kW	Option	Option	92919004	655	
	10 kW	Option	Option	92919005	740	
FFO Electric Heaters (also see heater rail) Single Stage Downflow (For 2 Stage Heaters add kits together, i.e. 8kW+8kW=16kW) Max Heater Loads 008=8kW, 010=10kW, 015=16kW, 020=20kW	2 kW	Option	Option	92919006	305	
	4 kW	Option	Option	92919007	415	
	6 kW	Option	Option	92919008	545	
	8 kW	Option	Option	92919009	655	
	10 kW	Option	Option	92919010	740	
FFO Electric Heaters 2 Stage Upflow Must be used with single stage heater (For 2 Stage Heaters add kits together, i.e. 8kW+8kW=16kW) Max Heater Loads 008=8kW, 010=10kW, 015=16kW, 020=20kW	2 kW	Option	Option	92919011	305	
	4 kW	Option	Option	92919012	415	
	6 kW	Option	Option	92919013	545	
	8 kW	Option	Option	92919014	655	
	10 kW	Option	Option	92919015	740	
FFO Electric Heaters 2 Stage Downflow Must be used with single stage heater (For 2 Stage Heaters add kits together, i.e. 8kW+8kW=16kW) Max Heater Loads 008=8kW, 010=10kW, 015=16kW, 020=20kW	2 kW	Option	Option	92919016	305	
	4 kW	Option	Option	92919017	415	
	6 kW	Option	Option	92919018	545	
	8 kW	Option	Option	92919019	655	
	10 kW	Option	Option	92919020	740	
FFO Heater Rail (Must be used with electric heaters)	008 U	Option	Option	92919021	155	
	010-015 U	Option	Option	92919024	165	
	020 U	Option	Option	92919026	165	
	080 DX D	Option	-	92919022	155	
	008 CW D	-	Option	92919023	165	
	010-015 D	Option	Option	92919025	165	
	020 D	Option	Option	92919027	165	
FFO LPHW Coil (Add De-Ice Stat with DX Systems)	9.6 kW	008 U/D	Option	Option	92900423	1270
	11.1 kW	010 U/D	Option	Option	92900424	1365
	12.0 kW	015 U/D	Option	Option	92900424	1365
	14.9 kW	020 U/D	Option	Option	92900425	1465
FFO LPHW VALVE	2 port on/off 24v	All models	Option	Option	92919048	830
	4 port diverting 24v	All models	Option	Option	92919049	805
	4 port modulating 0-10v	All models	Option	Option	92919050	POA
FFO CHILLED WATER VALVES	2 port on/off 24v	008/010	-	Option	92919042	830
		015/020	-	Option	92919043	1490
	4 port diverting 24v	008/010	-	Option	92919044	805
		015/020	-	Option	92919045	1850
	4 port modulating 0-10v	008/010	-	Option	92919046	POA
		015/020	-	Option	92919047	POA
1 phase conversion kit (for configurable units only) when using 1 phase condensing units Please contact TEV Ltd Technical Services				929111**	FOC	

CD3

Configurable Factory Fitted Options Continued



DESCRIPTION		MODEL	DX CONFIGURED	CHILLED WATER CONFIGURED	FACTORY FITTED PART NO.	PRICE (€)
FFO De-Ice Stat- DX only	One per DX circuit (Fit to DX/LPHW systems)	All models	Option	-	92919055	145
FFO Humidifier	0-4kg/h	008 U	Option	Option	92919028	1830
		010 U, 015 U	Option	Option	92919029	1875
		020 U	Option	Option	92919030	1875
		008 D	Option	Option	92919031	1875
		010 D, 015 D	Option	Option	92919032	1875
		020 D	Option	Option	92919033	1875
FFO Condensate Pump (complete with high water alarm)	(Hot & Cold, 5m head)	All models	Option	Option	92919054	620
FFO Fresh Air Spigot (for use with fan)	100mm dia.	All models	Option	Option	92900462	375
	150mm dia.	All models	Option	Option	92900463	685
FFO Fresh Air Fan (for use with spigot)	93 ³ m /h	All models	Option	Option	92900403	275
	186m /h	All models	Option	Option	92900404	370
FFO Sound Attenuator Section (430mm high) (packed separately) (supplied as standard to Upflow units)		008 D	Option	Option	92900475	1095
		010 D, 015 D	Option	Option	92900476	1175
		020 D	Option	Option	92900477	1250
FFO Floor Stand Plinth 75mm high (Recommended for use with all floor standing units and for side entry of services)		008 U	Option	Option	92900432	420
		010 U, 015 U	Option	Option	92900433	450
		020 U	Option	Option	92900434	470
		008 D	Option	Option	92900435	415
		010 D, 015 D	Option	Option	92900436	435
		020 D	Option	Option	92900437	460
FFO Downflow Plinth 300mm high	Air Discharge Front	008 D	Option	Option	92900481	990
	Front	010 D, 015 D	Option	Option	92900482	1045
	Front	020 D	Option	Option	92900483	1095
	Rear	008 D	Option	Option	92900484	1370
	Rear	010 D, 015 D	Option	Option	92900485	1435
	Rear	020 D	Option	Option	92900486	1515
FFO Double Deflection Grille (upflow only)		008 U	Option	Option	92900494	305
		010 U, 015 U	Option	Option	92900495	320
		020 U	Option	Option	92900496	370
		008 D	Option	Option	92900438	165
FFO Disposable Filter (BS EN 779 G3) - 50mm (Replaces washable filter)		010 U, 015 U	Option	Option	92900439	165
		020 U	Option	Option	92900440	170
		008 D	Option	Option	92900441	POA
		010 D, 015 D	Option	Option	92900442	POA
		020 D	Option	Option	92900443	POA
		008 U/D	Option	Option	92900478	1275
FFO H.E. Filters (BS EN 779 F8) - 100mm (Includes additional plenum section)		010 U/D, 015 U/D	Option	Option	92900479	1395
		020 U/D	Option	Option	92900480	1510
		008 U/D	Option	Option	92919051	310
FFO Isolator - 63A		010 U/D, 015 U/D	Option	Option	92919052	310
		020 U/D	Option	Option	92919053	310
		008 U	Option	Option	92919137	830
Return air plinth (Front duct) (Upflow only)		010U, 015U	Option	Option	92919138	880
		020 U	Option	Option	92919139	930

U= Upflow D= Downflow

CLOSE CONTROL

CD3

Configurable Factory Fitted Options Continued



DESCRIPTION		MODEL	DX CONFIGURED	CHILLED WATER CONFIGURED	FACTORY FITTED PART NO.	PRICE (€)
FFO Upflow Plinth 300mm high Includes spigot	<i>Air Discharge Rear</i>	008 U	Option	Option	92919105	1490
	Rear	010 U, 015 U	Option	Option	92919106	1485
	Rear	020 U	Option	Option	92919107	1585
FFO Plenum complete with spigot 430mm high	<i>Air Discharge Front/Rear</i>	008 U	Option	Option	92919108	910
	Front/Rear	010 U, 015 U	Option	Option	92919109	1000
	Front/Rear	020 U	Option	Option	92919110	1005
FFO Top Ducting Spigot (When used as return air spigot on Downflow units sound attenuator section is required for access to filters)		008 U	Option	Option	92900459	910
		010 U, 015 U	Option	Option	92900460	1000
		020 U	Option	Option	92900461	1005
		008 D	Option	Option	92919111	250
		010 D, 015 D	Option	Option	92919112	250
		020 D	Option	Option	92919113	255
CONTROLS						
FFO Remote control panel (includes 6m cable) Supplied loose	For units without isolator	008	Option	Option	92919078	415
		010, 015	Option	Option	92919079	415
		020	Option	Option	92919080	415
	For units fitted with isolator	008	Option	Option	92919081	415
		010, 015	Option	Option	92919082	415
		020	Option	Option	92919083	415
BACnet Interface Card			Option	Option	92919134	525
BACnet RS485 converter			Option	Option	92919136	415
Fan Speed transformer		"008 - 1-off per unit 010-020 2-off per unit"	Option	Option	92919118	210
ALARMS						
FFO Water Spillage (if condensate pump fitted)		All models	Option	Option	92919066	130
FFO Water Spillage (if no condensate pump fitted)		All models	Option	Option	92919067	370
FFO Fan Failure		All models	Option	Option	92919069	245
FFO Condensing Unit 1 trip		All DX models	Option	-	92919073	220
FFO Condensing Unit 2 trip		2 Circuit Units Only	Option	-	92919075	220
FFO Dirty Filter indication		All models	Option	Option	92919071	245
FFO Common Alarm (Volt-free relay)		All models	Option	Option	92919056	210
INDOOR UNIT AUTO-CHANGEOVER						
FFO Changeover on Set Time and/or Alarm (including unit assist for high room condition)		All models	Option	Option	92919095	445
FFO Master/Slave		All models	Option	Option	92919096	445

U= Upflow D= Downflow

CELLAR COOLING

Cellarator CX(E)



CX(E) CELLARATOR SPLIT SYSTEM WITH STANDARD CONTROL (For 80m pipe runs on CKC50 and 80, 50m on CKC 20 and 30 Extended Pipe Kit Required)												
INDOOR UNIT						OUTDOOR UNIT					SYSTEM	
Model No	Part No	System Cooling Total kW	SHR	Heating kW	Price (€)	Model No	Single Phase (1ph) Part No	Price (€)	Three Phase (3ph) Part No	Price (€)	1ph Price (€)	3ph Price (€)
CX30	55917001	2.8	0.75	*	1150	CKC20	55050720	1645	-	-	2795	-
						DCU+ 20	54224028	2952	-	-	4102	-
CX40	55917002	3.3	0.68	*	1182	CKC30	55050730	1678	55050774	-	2860	-
						DCU+ 30	54224029	3259	54224035	3327	4441	4509
CX50	55917003	4.6	0.66	*	1234	CKC50	55050722	2096	55050776	-	3330	-
						DCU+ 50	54224031	3729	54224037	3858	4963	5092
CX70	55917004	6.8	0.63	*	1575	CKC80	55050723	2409	55050724	2475	3984	4050
						DCU+ 80	54224033	4590	54224039	4724	6165	6299

*Electric Heating Available - See Accessories. Cooling duties rated at 12.7°Cdb/10°C wb indoor, 27°C db outdoor.

CX(E) CELLARATOR SPLIT SYSTEM WITH ELECTRONIC CONTROL (For 80m pipe runs on CKC50 and 80, 50m on CKC 20 and 30 Extended Pipe Kit Required)												
INDOOR UNIT						OUTDOOR UNIT					SYSTEM	
Model No	Part No	System Cooling Total kW	SHR	Heating kW	Price (€)	Model No	Single Phase (1ph) Part No	Price (€)	Three Phase (3ph) Part No	Price (€)	1ph Price (€)	3ph Price (€)
CXE30	55917017	2.8	0.75	*	1439	CKC20	55050720	1645	-	-	2795	-
						DCU+ 20	54224028	2952	-	-	4102	-
CXE40	55917016	3.3	0.68	*	1481	CKC30	55050730	1678	55050774	-	2860	-
						DCU+ 30	54224029	3259	54224035	3327	4441	4509
CXE50	55917015	4.6	0.66	*	1533	CKC50	55050722	2096	55050776	-	3330	-
						DCU+ 50	54224031	3729	54224037	3858	4963	5092
CXE70	55917014	6.8	0.63	*	1896	CKC80	55050723	2409	55050724	2475	3984	4050
						DCU+ 80	54224033	4590	54224039	4724	6165	6299

*Electric Heating Available - See Accessories. Cooling duties rated at 12.7°Cdb/10°C wb indoor, 27°C db outdoor.

Indoor Unit Accessories

Description	Model	Model	Factory Fitted	Field Fit Kits	Price (€)
	CX	CXE	Part No.	Part No.	
Electric Heater* 3.0kW	ALL	-	55900703	55900700	335
Electric Heater* 3.0kW	-	ALL	55900716	55900715	335
Digital Temperature Display	ALL	STD	55900704	55900701	275
Air Straightener Kit**	ALL	ALL	-	55900714	100
De-Ice Thermostat Kit	ALL	STD	55900705	55900702	90
Extended Pipe Run Kit	30,40,50	30,40,50	-	55900709	50
	70	70	-	55900710	50
Kit Mounting Extension	ALL	ALL	-	55900718	65

*Electric heater rated at 230v.

**For narrow cellar environments requiring an airtrow of 30-45m

Adaptor kits to facilitate 20-50m pipe runs model CX(E)30 and CX(E)40, 20-80m pipe runs models CX(E)50 and CX(E)70, including 20m lift

Outdoor Unit Accessories

Description	CKC	Part No.	Price (€)
Wall mounting kit	ALL	55000420	110
Mains isolator kit	CKC 20-60 1ph	55023220	170
	CKC 80 1ph	55023221	260
	CKC 80 3ph	55023222	200
Compressor jacket	CKC 20-30	55000423	125
	CKC 50-80	55000424	140
Overload kit (standard on 3ph)	CKC 20	55023317	140
	CKC 30-50	55023318	150
	CKC 80	55023319	170
Kit Panel Insulation	CKC 20-40	55021800	90
	CKC 50-80	55021801	100

CELLAR COOLING

Cellarator CXE



CXE LOW TEMPERATURE SPLIT SYSTEM

INDOOR UNIT						OUTDOOR UNIT					SYSTEM	
Model No	Part No	System Cooling Total kW	SHR	Heating kW	Price (€)	Model No	Single Phase (1ph) Part No	Price (€)	Three Phase (3ph) Part No	Price (€)	1ph Price (€)	3ph Price (€)
CXE40	55917016	2.3	0.85	*	1481	CKC20	55050720	1645	-	-	3126	-
						DCU+ 20	54224028	2952	-	-	4433	-
CXE50	55917015	3.5	0.80	*	1533	CKC40	55050741	1942	-	-	3475	-
						DCU+ 40	54224030	3338	54224036	3477	3338	5010
CXE70	55917014	5.0	0.70	*	1896	CKC60	55050740	2162	-	-	4058	-
						DCU+ 60	54224032	4411	54224038	4545	4411	6441

*Electric Heating Available - See Accessories.

Cooling duties rated at 5°Cdb/3°C wb indoor, 27°C db outdoor.

Indoor Unit Accessories

Description	CXE	Factory Fitted Part No.	Field Fit Kits Part No.	Price (€)
Electric Heater* 3.0kW	ALL	55900716	55900715	335
Air Straighteners Kit**	ALL	-	55900714	100
Extended Pipe Run Kit	30,40,50	-	55900709	50
	70	-	55900710	50
Kit Mounting Extension	ALL	-	55900718	65

*Electric heater rated at 230v.

**For narrow cellar environments requiring an athrow of 30-45m

Adaptor kits to facilitate 20-50m pipe runs model CX(E)30 and CX(E)40, 20-80m pipe runs models CX(E)50 and CX(E)70, including 20m lift

Outdoor Unit Accessories

Description	CKC	Part No.	Price (€)
Wall mounting kit	ALL	55000420	110
Mains isolator kit	CKC 20-60 1ph	55023220	170
	CKC 80 1ph	55023221	260
	CKC 80 3ph	55023222	200
Compressor jacket	CKC 20-30	55000423	125
	CKC 50-80	55000424	140
Overload kit (standard on 3ph)	CKC 20	55023317	140
	CKC 30-50	55023318	150
	CKC 80	55023319	170
Kit Panel Insulation	20-40	55021800	90
	50-80	55021801	100

NB: All accessories are field fit kits

For factory fitted accessories please contact Marstair on **01484 405666**

CELLAR COOLING

Cellarator CXA



CXA CELLARATOR SPLIT SYSTEM WITH STANDARD CONTROL

INDOOR UNIT						OUTDOOR UNIT			SYSTEM
Model No	Part No	System Cooling Total kW	SHR	Heating kW	Price (€)	Model No	Single Phase (1ph) Part No	Price (€)	1ph Price (€)
CXA 35	56417004	2.3	0.87	*	1050	CKA35	56517002	906	1956
CXA 50	56417005	3.3	0.76	*	1460	CKA35	56517002	906	2366
CXA 50	56417005	4.3	0.68	*	1460	CKA50	56517003	1350	2810
CXA 70	56417007	5.6	0.68	*	1617	CKA 70	56517004	1974	3591

*Electric Heating Available - See Accessories.

Cooling duties rated at 12.7°Cdb/10°C wb indoor, 27°C db outdoor.

CXEA CELLARATOR SPLIT SYSTEM WITH ELECTRONIC CONTROL

INDOOR UNIT						OUTDOOR UNIT			SYSTEM
Model No	Part No	System Cooling Total kW	SHR	Heating kW	Price (€)	Model No	Single Phase (1ph) Part No	Price (€)	1ph Price (€)
CXEA 35	56417002	2.3	0.87	*	1197	CKA35	56517002	906	2103
CXEA 50	56417003	3.3	0.76	*	1602	CKA35	56517002	906	2508
CXEA 50	56417003	4.3	0.68	*	1602	CKA50	56517003	1350	2952
CXEA 70	56417006	5.6	0.68	*	1812	CKA 70	56517004	1974	3786

*Electric Heating Available - See Accessories.

Cooling duties rated at 12.7°Cdb/10°C wb indoor, 27°C db outdoor.

Indoor Unit Accessories

Description	CXA	CXEA	Factory Fitted Part No.	Price (€)	Field Fit Kits Part No.	Price (€)
Electric Heater* 3.0kW	ALL	-	55900703	352	55900700	335
	-	ALL	55900716	352	55900715	335
Digital Temperature Display	ALL	STD	55900704	255	55900701	275
Air Straighteners Kit**	ALL	ALL	-	-	55900714	100
Kit Mounting Extension	ALL	ALL	-	-	55900718	65

*Electric heater rated at 230v.

**For narrow cellar environments requiring an athrow of 30-45m

MULTI-SPLITS

Cellar Cooling

Multi - Splits

Cooling Duty 12.7°C indoor and 27°C external ambient



CELLAR COOLING MULTI SPLITS														
EVAPORATORS						CONDENSING UNITS					SYSTEM			
Model No	Part No MASTER	Part No SLAVE	System Cooling Total kW	Price per Unit (€)	Total Price(€)	Model No	Single Phase (1ph) Part No	Price (€)	Three Phase (3ph) Part No	Price(€)	Expansion Assembly	Price (€)	1ph Price (€)	3ph Price (€)
2 x CXE30	55917026	55917056	4.80	1439	2878	CKC50	55050722	1390	55050776	1930	55023327	150	4418	4958
2 x CXE50	55917028	55917058	6.90	1533	3066	CKC80	55050723	1390	55050724	1930	55023329	150	4606	5146
2 x CXE50	55917028	55917058	7.30	1533	3066	CKC90	55050771	1390	55050778	1930	55023330	150	4606	5146
2 x CXE50	55917028	55917058	8.20	1533	3066	CKC100	-	-	55050779	1930	55023331	150	-	5146
2 x CXE70	55917029	55917059	8.80	1896	3792	CKC100	-	-	55050779	1930	55023331	150	-	5872
2 x CXE70	55917029	55917059	10.00	1896	3792	CKC130	-	-	55050780	3910	55023332	150	-	7852
2 x CXE70	55917029	55917059	11.00	1166	2332	CKC150	-	-	55050781	4175	55023333	150	-	6657
3 x CXE50	55917028	2 x 55917058	9.10	1533	4599	CKC100	-	-	55050779	1930	55023331	150	-	6679
3 x CXE50	55917028	2 x 55917058	10.20	1533	4599	CKC130	-	-	55020780	3910	55023332	150	-	8659
3 x CXE50	55917028	2 x 55917058	11.30	1533	4599	CKC150	-	-	55020781	4175	55023333	150	-	8924
3 x CXE50	55917028	2 x 55917058	12.50	1533	4599	CKC165	-	-	55020782	5690	55023334	150	-	10439
3 x CXE70	55917029	2 x 55917059	10.00	1896	5688	CKC100	-	-	55020779	1930	55023331	150	-	7768
3 x CXE70	55917029	2 x 55917059	11.10	1896	5688	CKC130	-	-	55020780	3910	55023332	150	-	9748
3 x CXE70	55917029	2 x 55917059	11.50	1896	5688	CKC150	-	-	55020781	4175	55023333	150	-	10013
3 x CXE70	55917029	2 x 55917059	12.70	1896	5688	CKC165	-	-	55020782	4590	55023334	150	-	10428
3 x CXE70	55917029	2 x 55917059	14.00	1896	5688	CKC 180	-	-	55020783	4995	55023335	150	-	10833

Accessories

Description	Part No.	Price (€)
FFO 3kW heater Kit MASTER	55900721	335
FFO 3kW heater Kit SLAVE	55900722	335
Kit Air Straightner	55900714	100

A2L CELLAR COOLING

A2L CELLAR MATCH

CXE A2L



INDOOR UNIT				OUTDOOR UNIT					SYSTEM	
Model No	Part No	System Cooling Total kW	Price (£)	Model No	Single Phase (1ph) Part No	Price (£)	Three Phase (3ph) Part No	Price (£)	1ph Price (£)	3ph Price (£)
CXE30 A2L	55921001	2.4	1330	SMC20	55030004	4620	-	-	5950	-
CXE30 A2L	55921001	2.7	1330	SMC30	55030005	4740	-	-	6070	-
CXE50 A2L	55921003	4.4	1422	SMC45	-	-	55030022	5520	-	6942
CXE70 A2L	55921004	6.2	1675	SMC50	-	-	55030023	5760	-	7435
CXE70 A2L	55921004	7.4	1675	SMC80	-	-	55030025	6000	-	7675

Indoor Unit Accessories

Description	CXE	Factory Fitted Part No.	Field Fit Kits Part No.	Price (£)
Air Straighteners Kit**	ALL	-	55900714	100
Kit Mounting Extension	ALL	-	55900718	65

**For narrow cellar environments requiring an airtthrow of 30-45m

REFRIGERATION

Low Temperature Cassette

600 x 600mm Cassette



LOW TEMPERATURE CASSETTE SPLIT SYSTEM (FACTORY CHARGED WITH R407C REFRIGERANT)

INDOOR UNIT						FASCIA		OUTDOOR UNIT						SYSTEM (INC FASCIA)		
Model No	Part No	System Cooling Total kW	SHR	Based at Deg C	Price (€)	Part No	Price (€)	Model No	Single Phase (1ph) Part No.	Price (€)	Three Phase (3ph) Part No.	Price (€)	Expansion Assembly Part NO.	Price(€)	1ph Price (€)	3ph Price (€)
CC 600 20	55222004	1.74	0.71	16	1651	55222000	311	CKC15	55050769	1529	-	-	55023323	150	3641	-
								DCU+15	54224027	2851	-	-	55023337	150	4502	-
CC 600 40	55222005	1.72	0.78	10	1776	55222000	311	CKC15	55050769	1529	-	-	55023323	150	3766	-
								DCU+15	54224027	2851	-	-	55023337	150	5088	-
		2.2	0.75	12		55222000	311	CKC20	55050720	1645	-	-	55023323	150	3882	-
								DCU+20	54224028	2952	-	-	55023338	150	5189	-
		2.97	0.64	14		55222000	311	CKC30	55050730	1678	55050774	2123	55023324	150	3915	4360
								DCU+30	54224029	3259	54224035	3327	55023339	150	5496	5564
CC 600 60	55222006	2.2	0.76	10	1920	55222000	311	CKC20	55050720	1645	-	-	55023323	150	4026	-
								DCU+20	54224028	2952	-	-	55023338	150	5333	-
		3.05	0.70	12		55222000	311	CKC30	55050730	1678	55050774	2123	55023324	150	6182	4504
								DCU+30	54224029	3259	54224035	3327	55023339	150	5640	5708
4.52	0.61	14	55222000	311	CKC50	55050722	2096	55050776	2492	55023327	150	4477	6793			
					DCU+50	54224031	3729	54224037	3858	55023326	150	6110	6239			

Duties based on the unit "Installer adjusted to fan speed range three" for maximum cooling capacities.

For selections at "ranges one and two" and alternative conditions please refer to the relevant technical manual

Electric Heating Available - See Accessories

Note : For system combinations and duties at 'ultra low' sound operation, reference should be made to the relevant technical manual

Cooling duties based on 32°C exterior ambient

Accessories

Description		CC 600 E/M'	Part No	Price (€)
Electric Heater/ Electric Boost Heater (Heat Pump Systems)	1.0kW	ALL	55200317	295
	2.0kW	ALL	55200313	355
Motorised Vanes for heating mode		ALL	97100312	270
Remote Room Temperature Sensor		ALL	97200212	110
Fresh Air Inlet Spigot 100mm dia		ALL	55200305	140
Branch Duct Spigot 100mm dia		ALL	55200306	105
Programmable Timer		ALL	52500151	160
Discharge Blanking Kit (for 3 way discharge)		ALL	55500316	40
Master Slave Box		ALL	55600414	300

NB: All accessories are field fit kits

For factory fitted accessories please contact Marstair on **01484 405666**

Low Temperature Cassette

875 x 875mm Cassette



INDOOR UNIT					FASCIA		OUTDOOR UNIT				SYSTEM (INC FASCIA)					
Model No	Part No	System Cooling Total kW	SHR	Based at Deg C	Price (€)	Part No	Price (€)	Model No	Single Phase (1ph) Part No.	Price(€)	Three Phase (3ph) Part No.	Price (€)	Expansion Assembly Part NO.	Price (€)	1ph Price (€)	3ph Price (€)
CC 875 80	55522135	3.05	0.83	10	2489	55522000	404	CKC 30	55050730	1678	55050774	2123	55023324	150	4721	5166
		DCU+30	54224029	3259				54224035	3327	55023339	150	6706	6370			
		3.78	0.8	12				CKC 40	55050741	1942	55050775	2327	55023325	150	4985	5370
		DCU+40	54224030	3338				54224036	3477	55023340	150	6785	6520			
		5.41	0.66	14				CKC 60	55050740	2162	55050777	2602	55023328	150	5205	5645
		DCU+60	54224032	4411				54224038	4545	55023327	150	4965	7588			
CC 875 110	55522136	4.77	0.74	10	2680	55522000	404	CKC 50	55050722	2096	55050776	2492	55023327	150	5330	5726
		DCU+50	54224031	3729				54224037	3858	55023326	150	7367	7092			
		5.48	0.73	12				CKC 60	55050740	2162	55050777	2602	55023328	150	5396	5836
		DCU+60	54224032	4411				54224038	4545	55023327	150	7645	7779			
		6.47	0.65	14				CKC 80	55050723	2409	55050724	2475	55023329	150	5643	5709
		DCU+80	54224033	4590				54224039	4724	55023341	150	8228	7958			
CC 875 140	55522137	6.21	0.71	12	2839	55522000	404	CKC 80	55050723	2409	55050724	2475	55023329	150	5802	5868
		DCU+80	54224033	4590				54224039	4724	55023341	150	8387	8117			
		7.45	0.63	14				CKC 90	55050771	3317	55050778	3465	55023330	150	6710	6858
		8.67	0.59	16				CKC 100	-	-	55050779	3911	55023331	150	-	7304

Duties based on the unit "Installer adjusted to fan speed range two" for maximum cooling capacities.
For selections at "range one" and alternative conditions please refer to the relevant technical manual
Electric Heating Available - See Accessories

Note : For system combinations and duties at 'ultra low' sound operation, reference should be made to the relevant technical manual

Cooling duties based on 32°C exterior ambient

Accessories

Description	CC 875	Part No	Price (€)	
Electric Heater/ Electric Boost Heater (Heat Pump System)	1.0kW	ALL	55500311	355
	2.0kW	ALL	55500312	440
	3.0kW	ALL	55500313	495
	4.0kW 3ph	ALL	55500314	585
Return Air Sensor Kit	ALL	97200212	110	
Branch Duct Spigot 150mm dia	ALL	55500304	210	
Fresh Air Inlet Spigot 100mm dia	ALL	55200305	140	
Programmable Timer	ALL	52500151	160	
Discharge Blanking Kit (for 3 way discharge)	ALL	55500316	40	
Master Slave Box	ALL	55600414	300	

NB: All accessories are field fit kits

For factory fitted accessories please contact Marstair on **01484 405666**

REFRIGERATION

Wine Cellar Coolers WM (Wall Mounted)



LOW TEMPERATURE WALL MOUNTED UNIT (ELECTROMECHANICAL)

WM COOLING SYSTEMS - WIRED CONTROL INDOOR UNIT												
INDOOR UNIT 10°C INDOOR / 27°C EXTERNAL SYSTEM MATCHES				OUTDOOR UNIT					SYSTEM			
Model No	Part No	System Cooling Total kW	Price (€)	Model No	Single Phase (1ph) Part No.	Price(€)	Three Phase (3ph) Part No.	Price(€)	Expansion Assembly Part No.	Price(€)	1ph Price (€)	3ph Price (€)
60	55600001	1.7	1446	CKC+ 15	55050769	1529	-	-	55023323	150	3125	
				DCU+ 15	54224027	2851	-	-	55023337	150	4447	
80	55600002	2.3	1642	CKC+ 20	55050720	1645	-	-	55023323	150	3437	
				DCU+ 20	54224028	2952	-	-	55023338	150	4744	
100	55600003	3.0	1884	CKC+ 30	55050730	1678	55050774	2123	55023324	150	3712	4157
				DCU+ 30	54224029	3259	54224035	3327	55023339	150	5293	5361

WM COOLING SYSTEMS - WIRED CONTROL INDOOR UNIT												
INDOOR UNIT 12.7°C INDOOR / 27°C EXTERNAL SYSTEM MATCHES				OUTDOOR UNIT					SYSTEM			
Model No	Part No	System Cooling Total kW	Price (€)	Model No	Single Phase (1ph) Part No.	Price(€)	Three Phase (3ph) Part No.	Price(€)	Expansion Assembly Part No.	Price (€)	1ph Price (€)	3ph Price (€)
60	55600001	2.3	1446	CKC+ 20	55050720	1645	-	-	55023323	150	3241	
				DCU+ 20	54224028	2952	-	-	55023338	150	4548	
80	55600002	3.5	1642	CKC+ 40	55050741	1942	55050775	2327	55023325	150	3734	4119
				DCU+ 40	54224030	3338	54224036	3477	55023340	150	5130	5269
100	55600003	3.6	1884	CKC+ 40	55050741	1942	55050775	2327	55023325	150	3976	4361
				DCU+ 40	54224030	3338	54224036	3477	55023340	150	5372	5511

WM COOLING SYSTEMS - WIRED CONTROL INDOOR UNIT												
INDOOR UNIT 15°C INDOOR / 27°C EXTERNAL SYSTEM MATCHES				OUTDOOR UNIT					SYSTEM			
Model No	Part No	System Cooling Total kW	Price (€)	Model No	Single Phase (1ph) Part No.	Price(€)	Three Phase (3ph) Part No.	Price (€)	Expansion Assembly Part No.	Price (€)	1ph Price (€)	3ph Price (€)
60	55600001	3.0	1446	CKC+ 30	55050730	1678	55050774	1935	55023324	150	3274	3531
				DCU+ 30	54224029	3259	54224035	3327	55023339	150	4855	4923
80	55600002	4.6	1642	CKC+ 50	55050722	2096	55050776	2265	55023327	150	3888	4057
				DCU+ 50	54224031	3729	54224037	3858	55023326	150	5521	5650
100	55600003	5.0	1884	CKC+ 60	55050740	2162	55050777	2370	55023328	150	4196	4404
				DCU+ 60	54224032	4411	54224038	4545	55023327	150	6445	6579

* Electric Heating Available - See Accessorie

Accessories

Description	WM	Part No	Price (€)	
Electric Heater	1.3kW	60	55600401	275
	1.8kW	80	55600402	295
	2.3kW	100	55600403	320
Pipe Exit Kit	60	55600425	70	
	80-100	55600426	75	
Condensate Pump (5m head - with overflow protection)		55600420	225	
De-Ice Thermostat		53700411	70	
Programmable Timer		52500151	160	
Return Air Sensor Kit		97200212	110	
Master Slave Box	ALL	55600414	300	

NB: All accessories are field fit kits

For factory fitted accessories please contact Marstair on **01484 405666**

REFRIGERATION

Wine Cellar Coolers DXD (Concealed Ducted)

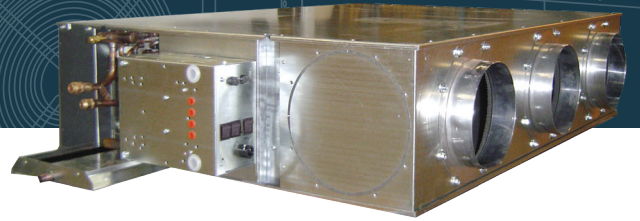

LOW TEMPERATURE DUCTED (ELECTROMECHANICAL)

3690DXD COOLING SYSTEMS - WIRED CONTROL INDOOR UNIT												
INDOOR UNIT 10°C INDOOR / 27°C EXTERNAL SYSTEM MATCHES				OUTDOOR UNIT					SYSTEM			
Model No	Part No	System Cooling Total kW	Price (£)	Model No	Single Phase (1ph) Part No.	Price (£)	Three Phase (3ph) Part No.	Price (£)	Expansion Assembly Part No.	Price (£)	1ph Price (£)	3ph Price (£)
50	56600021	1.9	2273	CKC+ 15	55050769	1529	-	-	55023323	150	3952	-
				DCU+ 15	54224027	2851	-	-	55023337	150	3001	-
60	56600022	2.4	2495	CKC+ 20	55050720	1645	-	-	55023323	150	4290	-
				DCU+ 20	54224028	2952	-	-	55023338	150	5597	-
90	56600024	3.8	2948	CKC+ 40	55050741	1942	55050775	2327	55023325	150	5040	5425
				DCU+ 40	54224030	3338	54224036	3477	55023340	150	6436	6575
130	56600026	3.9	3855	CKC+ 40	55050741	1942	55050775	2327	55023325	150	5947	6332
				DCU+ 40	54224030	3338	54224036	3477	55023340	150	7343	7482
150	56600027	5.1	4082	CKC+ 50	55050722	2096	55050776	2492	55023327	150	6328	6724
				DCU+ 50	54224031	3729	54224037	3858	55023326	150	7961	8090

DXD COOLING SYSTEMS - WIRED CONTROL INDOOR UNIT												
INDOOR UNIT 12.7°C INDOOR / 27°C EXTERNAL SYSTEM MATCHES				OUTDOOR UNIT					SYSTEM			
Model No	Part No	System Cooling Total kW	Price (£)	Model No	Single Phase (1ph) Part No.	Price (£)	Three Phase (3ph) Part No.	Price (£)	Expansion Assembly Part No.	Price (£)	1ph Price (£)	3ph Price (£)
50	56600021	2.5	2273	CKC+ 20	55050720	1645	-	-	55023323	150	4068	-
				DCU+ 20	54224028	2952	-	-	55023338	150	5375	-
60	56600022	3.2	2495	CKC+ 30	55050730	1678	55050774	2123	55023324	150	4323	4768
				DCU+ 30	54224029	3259	54224035	3327	55023339	150	5904	5972
90	56600024	5.5	2948	CKC+ 60	55050740	2162	55050777	2602	55023328	150	5260	5700
				DCU+ 60	54224032	4411	54224038	4545	55023327	150	7509	7643
130	56600026	5.6	3855	CKC+ 60	55050740	2162	55050777	2602	55023328	150	6167	6607
				DCU+ 60	54224032	4411	54224038	4545	55023327	150	8416	8550
150	56600027	6.6	4082	CKC+ 80	55050008	2525	55050724	2475	55023329	150	6757	6707
				DCU+ 80	55050723	2409	54224039	4724	55023341	150	6641	8956

DXD COOLING SYSTEMS - WIRED CONTROL INDOOR UNIT												
INDOOR UNIT 15°C INDOOR / 27°C EXTERNAL SYSTEM MATCHES				OUTDOOR UNIT					SYSTEM			
Model No	Part No	System Cooling Total kW	Price (£)	Model No	Single Phase (1ph) Part No.	Price (£)	Three Phase (3ph) Part No.	Price (£)	Expansion Assembly Part No.	Price (£)	1ph Price (£)	3ph Price (£)
50	56600021	3.3	2273	CKC+ 30	55050730	1678	55050774	2123	55023324	150	4101	4546
				DCU+ 30	54224029	3259	54224035	3327	55023339	150	5682	5750
60	56600022	3.9	2495	CKC+ 40	55050741	1942	55050775	2327	55023325	150	4587	4972
				DCU+ 40	54224030	3338	54224036	3477	55023340	150	5983	6122
90	56600024	6.6	2948	CKC+ 80	55050723	2409	55050724	2475	55023329	150	5507	5573
				DCU+ 80	54224033	4590	54224039	4724	55023341	150	7688	7822
130	56600026	7.5	3855	CKC+ 90	55050771	3317	55050778	3465	55023330	150	7322	7470
150	56600027	8.4	4082	CKC+ 100	-	-	55050779	3911	55023331	150	-	8143

* Electric Heating Available - See Accessorie

REFRIGERATION

Wine Cellar Coolers DXD (Concealed Ducted)

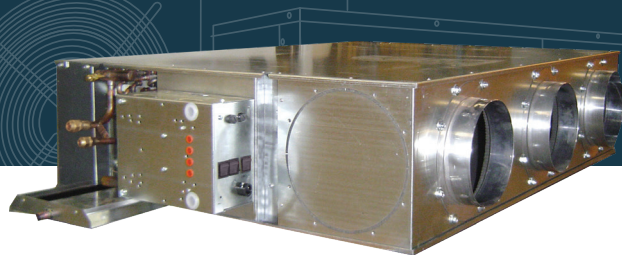

Accessories

Description		DXD	Part No	Price (€)
FFO Electric Heater	2.0kW	50-60	56600406	335
	2.0kW	90	56600407	430
	3.0kW	130	56600408	505
	4.0kW	150	56600409	595
FFO Return Air Plenum 50		50	56600401	300
FFO Return Air Plenum 60		60	56600402	320
FFO Return Air Plenum 90		90	56600403	370
FFO Return Air Plenum 130		130	56600404	410
FFO Return Air Plenum 150		150	56600405	445
Discharge/Inlet Spigot	200mm Dia	ALL	48002094	60
	250mm Dia	ALL	48001985	40
FFO LPHW Coil		50 RH	48023048	270
FFO LPHW Coil		60 RH	48023050	300
FFO LPHW Coil		90 RH	48023052	410
FFO LPHW Coil		130 RH	48023054	465
FFO LPHW Coil		150 RH	48023056	525
Return Air Sensor Kit		ALL	97200212	110
FFO Condensate Pump		ALL	56600423	305
Programmable Timer Kit		ALL	52500151	160
Master Slave Box		ALL	55600414	300

NB: All accessories are field fit kits

For factory fitted accessories please contact Marstair on **01484 405666**



Low Temperature Air Conditioning

DXT Wall Mounted Unit (Ceiling Mounted Option) - Cased Units

LOW TEMPERATURE WALL MOUNTED (ELECTROMECHANICAL)

DXT COOLING SYSTEMS - WIRED CONTROL INDOOR UNIT												
INDOOR UNIT 10°C INDOOR / 27°C EXTERNAL SYSTEM MATCHES				OUTDOOR UNIT					SYSTEM			
Model No	Part No	System Cooling Total kW	Price (€)	Model No	Single Phase (1ph) Part No.	Price(€)	Three Phase (3ph) Part No.	Price(€)	Expansion Assembly Part No.	Price(€)	1ph Price(€)	3ph Price(€)
9*	5670009*	2.3	2053	CKC 20	55050720	1645	-	-	55023323	150	3848	-
				DCU+ 20	54224028	2952	-	-	55023338	150	5155	-
10*	5670010*	2.8	2930	CKC 30	55050730	1678	55050774	2123	55023324	150	4758	5203
				DCU+ 30	54224029	3259	54224035	3327	55023339	150	6339	6407
10*	56700106*	2.8	4263	CKC 30	55050730	1678	55050774	2123	55023324	150	6091	6536
				DCU+ 40	54224029	3259	54224035	3327	55023339	150	7672	7740
12*	5670012*	3.4	3313	CKC 40	55050741	1942	55050775	2327	55023325	150	5405	5790
				DCU+ 40	54224030	3338	54224036	3477	55023340	150	6801	6940
12*	56700126	3.4	3313	CKC 40	55050741	1942	55050775	2327	55023325	150	5405	5790
				DCU+ 40	54224030	3338	54224036	3477	55023340	150	6801	6940

DXT COOLING SYSTEMS - WIRED CONTROL INDOOR UNIT												
INDOOR UNIT 12.7°C INDOOR / 27°C EXTERNAL SYSTEM MATCHES				OUTDOOR UNIT					SYSTEM			
Model No	Part No	System Cooling Total kW	Price (€)	Model No	Single Phase (1ph) Part No.	Price (€)	Three Phase (3ph) Part No.	Price (€)	Expansion Assembly Part No.	Price (€)	1ph Price (€)	3ph Price(€)
7*	5670007*	1.9	1901	CKC 15	55050769	1529	-	-	55023323	150	3580	-
				DCU+ 15	54224027	2851	-	-	55023337	150	4902	-
9*	5670009*	3.0	2053	CKC 30	55050730	1678	55050774	2123	55023324	150	3881	4326
				DCU+ 30	54224029	3259	54224035	3327	55023339	150	5462	5530
10*	5670010*	3.4	2930	CKC 40	55050741	1942	55050775	2327	55023325	150	5022	5407
				DCU+ 40	54224030	3338	54224036	3477	55023340	150	6418	6557
10*	56700106*	3.4	4263	CKC 40	55050741	1942	55050775	2327	55023325	150	6355	6740
				DCU+ 40	54224030	3338	54224036	3477	55023340	150	7751	7890
12*	5670012*	4.5	3313	CKC 50	55050722	2096	55050776	2492	55023327	150	5559	5955
				DCU+ 50	54224031	3729	54224037	3858	55023326	150	7192	7321
12*	5670012*	4.5	3313	CKC 50	55050722	2096	55050776	2492	55023327	150	5559	5955
				DCU+ 50	54224031	3729	54224037	3858	55023326	150	7192	7321

DXT COOLING SYSTEMS - WIRED CONTROL INDOOR UNIT												
INDOOR UNIT 15°C INDOOR / 27°C EXTERNAL SYSTEM MATCHES				OUTDOOR UNIT					SYSTEM			
Model No	Part No	System Cooling Total kW	Price (€)	Model No	Single Phase (1ph) Part No.	Price (€)	Three Phase (3ph) Part No.	Price (€)	Expansion Assembly Part No.	Price (€)	1ph Price(€)	3ph Price(€)
7*	5670007*	2.2	1901	CKC 20	55050720	1645	-	-	55023323	150	3696	-
				DCU+ 20	54224028	2952	-	-	55023338	150	5003	-
9*	5670009*	3.5	2053	CKC 40	55050741	1942	55050775	2327	55023325	150	4145	4530
				DCU+ 40	54224030	3338	54224036	3477	55023340	150	5541	5680
10*	5670010*	4.4	2930	CKC 50	55050722	2096	55050776	2492	55023327	150	5176	5572
				DCU+ 50	54224031	3729	54224037	3858	55023326	150	6809	6938
10*	56700106*	4.4	4263	CKC 50	55050722	2096	55050776	2492	55023327	150	6509	6905
				DCU+ 50	54224031	3729	54224037	3858	55023326	150	8142	8271
12*	5670012*	5.7	3313	CKC 80	55050723	2409	55050724	2475	55023329	150	5872	5938
				DCU+ 80	54224033	4590	54224039	4724	55023341	150	8053	8187
12*	56700126	5.7	3313	CKC 80	55050723	2409	55050724	2475	55023329	150	5872	5938
				DCU+ 80	54224033	4590	54224039	4724	55023341	150	8053	8187



Low Temperature Air Conditioning

DXT Wall Mounted Unit (Ceiling Mounted Option) - **Cased Units**

Accessories

DESCRIPTION		DXT	PART NO.	PRICE (€)
Electric Heater Case 0-5-8	0.6 kW	10	40906086	365
	1.0 kW	20	40906087	365
	1.0 kW	40	40906088	390
	2.0 kW	60	40906090	415
	2.0 kW	70	40906091	415
	3.0 kW	90	40906092	430
	3.0 kW	100	40906093	820
	4.5 kW	120	40906096	840
Electric Heater Case 1-4-9	0.6 kW	10	40906097	365
	1.0 kW	20	40906098	365
	1.0 kW	40	40906099	390
	2.0 kW	60	40906100	415
	2.0 kW	70	40906101	415
	3.0 kW	90	40906102	430
	3.0 kW	100	40906103	820
	4.5 kW	120	40906106	840
Condensate Pump	Horizontal	10 - 60	40905016	935
	Horizontal	70 - 120	40905017	935
	Vertical	10 - 60	40905018	935
	Vertical	70 - 120	40905019	935
Fitted TEV			N/A	POA
Thermostat with Dial (RCC 30)		ALL	97200211	155
Thermostat with Digital Display (RDG 100)		ALL	485233	160
Thermostat with Timer (RDG 100T)		ALL	485229	255
Return Air Sensor Kit		ALL	97200212	110
Volt Free Relay	240V	ALL	48000410	125
Volt Free Relay	24V	ALL	48000411	125
Master Slave Box		ALL	55600414	300

Vertical Cased Units

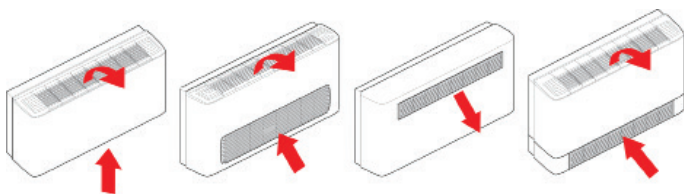

Version 0

Version 5

Version 6

Version 8

Horizontal Cased Units

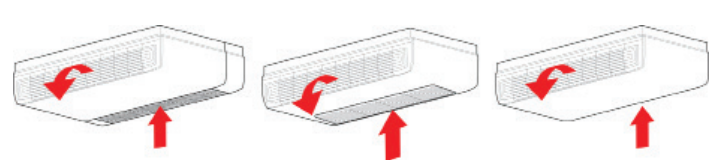

Version 1

Version 4

Version 9



Low Temperature Air Conditioning

DXT Wall Mounted Unit (Ceiling Mounted Option) - Chassis Units

LOW TEMPERATURE WALL MOUNTED (ELECTROMECHANICAL)

DXT COOLING SYSTEMS - WIRED CONTROL INDOOR UNIT												
INDOOR UNIT 10°C INDOOR / 27°C EXTERNAL SYSTEM MATCHES				OUTDOOR UNIT					SYSTEM			
Model No	Part No	System Cooling Total kW	Price (£)	Model No	Single Phase (1ph) Part No.	Price (£)	Three Phase (3ph) Part No.	Price (£)	Expansion Assembly Part No.	Price (£)	1ph Price (£)	3ph Price (£)
9*	5670009*	2.3	1665	CKC 20	55050720	1645	-	-	55023323	150	3460	-
				DCU+ 20	54224028	2952	-	-	55023338	150	4767	-
10*	5670010*	2.8	2270	CKC 30	55050730	1678	55050774	2123	55023324	150	4098	4543
				DCU+ 30	54224029	3259	54224035	3327	55023339	150	5679	5747
12*	5670012*	3.4	2540	CKC 40	55050741	1942	55050775	2327	55023325	150	4632	5017
				DCU+ 40	54224030	3338	54224036	3477	55023340	150	6028	6167

DXT COOLING SYSTEMS - WIRED CONTROL INDOOR UNIT												
INDOOR UNIT 12.7°C INDOOR / 27°C EXTERNAL SYSTEM MATCHES				OUTDOOR UNIT					SYSTEM			
Model No	Part No	System Cooling Total kW	Price (£)	Model No	Single Phase (1ph) Part No.	Price (£)	Three Phase (3ph) Part No.	Price (£)	Expansion Assembly Part No.	Price (£)	1ph Price (£)	3ph Price (£)
7*	5670007*	1.9	1475	CKC 15	55050769	1529	-	-	55023323	150	3154	-
				DCU+ 15	54224027	2851	-	-	55023337	150	4476	-
9*	5670009*	3.0	1665	CKC 30	55050730	1678	55050774	2123	55023324	150	3493	3938
				DCU+ 30	54224029	3259	54224035	3327	55023339	150	5074	5142
10*	5670010*	3.4	2270	CKC40	55050741	1942	55050775	2327	55023325	150	4362	4747
				DCU+ 40	54224030	3338	54224036	3477	55023340	150	5758	5897
12*	5670012*	4.5	2540	CKC 50	55050722	2096	55050776	2492	55023327	150	4786	5182
				DCU+ 50	54224031	3729	54224037	3858	55023326	150	6419	6548

DXT COOLING SYSTEMS - WIRED CONTROL INDOOR UNIT												
INDOOR UNIT 15°C INDOOR / 27°C EXTERNAL SYSTEM MATCHES				OUTDOOR UNIT					SYSTEM			
Model No	Part No	System Cooling Total kW	Price (£)	Model No	Single Phase (1ph) Part No.	Price (£)	Three Phase (3ph) Part No.	Price (£)	Expansion Assembly Part No.	Price (£)	1ph Price (£)	3ph Price (£)
7*	5670007*	2.2	1475	CKC 20	55050720	1645	-	-	55023323	150	3270	-
				DCU+ 20	54224028	2952	-	-	55023338	150	4577	-
9*	5670009*	3.5	1665	CKC 40	55050741	1942	55050775	2327	55023325	150	3757	4142
				DCU+ 40	54224030	3338	54224036	3477	55023340	150	5153	5292
10*	5670010*	4.4	2270	CKC 50	55050722	2096	55050776	2492	55023327	150	4516	4912
				DCU+ 50	54224031	3729	54224037	3858	55023326	150	6149	6278
12*	5670012*	5.7	2540	CKC 80	55050723	2409	55050724	2475	55023329	150	5099	5165
				DCU+ 80	54224033	4590	54224039	4724	55023341	150	7280	7414

* See diagram for cased unit number ending in 2, 3, & 7.

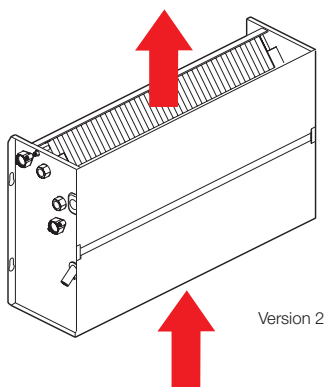

Vertical Chassis Units

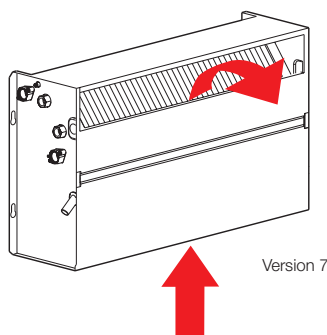

Version 7

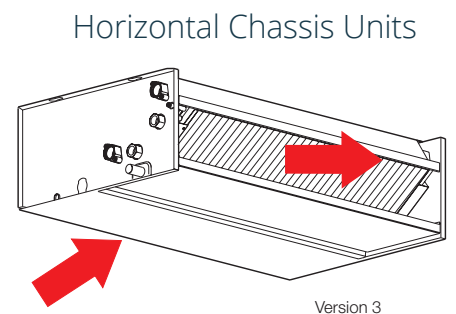

Version 3



Low Temperature Air Conditioning

DXT Wall Mounted Unit (Ceiling Mounted Option) - **Chassis Units**

Accessories

DESCRIPTION		DXT	PART NO.	PRICE (€)
Electric Heater	0.6 kW	10	40906107	365
	1.0 kW	20	40906108	365
	1.0 kW	40	40906109	390
	2.0 kW	60	40906110	415
	2.0 kW	70	40906111	415
	3.0 kW	90	40906112	430
	3.0 kW	100	40906113	820
Condensate Pump	4.5 kW	120	40906116	840
	Horizontal	10 - 60	40905016	935
	Horizontal	70 - 120	40905017	935
	Vertical	10 - 60	40905018	935
Vertical	70 - 120	40905019	935	
	Fitted TEV		N/A	POA
Thermostat with Dial (RCC 30)		ALL	97200211	155
Thermostat with Digital Display (RDG 100)		ALL	485233	160
Thermostat with Timer (RDFG 100T)		ALL	485229	255
Return Air Sensor Kit		ALL	97200212	110
Volt Free Relay	240V	ALL	48000410	125
Volt Free Relay	24V	ALL	48000411	125
Master Slave Box		ALL	55600414	300

REFRIGERATION

MRC(+) Condensing Units

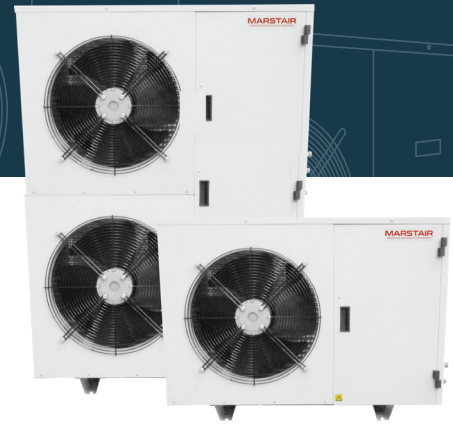

MRC+ MEDIUM TEMPERATURE CONDENSING UNIT

OUTDOOR UNIT								
Model No	Nominal Cooling Duty kW	Single Phase (1 ph) Part No.	Compressor Type	Price (€)	Three Phase (3 ph) Part No.	Compressor Type	Price (€)	
MRC+	15	1.1	55050979	reciprocating	2588	-	-	-
	20	1.4	55050980	reciprocating	2604	-	-	-
	30	2.0	55050981	reciprocating	2626	55050987	reciprocating	2702
	40	2.9	55050982	reciprocating	2778	55050988	reciprocating	2854
	45	2.9	55050920	scroll	2892	-	-	-
	50	3.9	55050983	scroll	2979	55050989	scroll	3093
	60	4.6	55050984	scroll	3038	55050990	scroll	3190
	80	5.5	55050985	scroll	3261	55050991	scroll	3407
	90	6.4	55050986	scroll	3869	55050992	scroll	3944
	100	7.1	55050998	scroll	4438	55050993	scroll	4438
	130	8.1	-	-	-	55050994	scroll	5019
	150	8.8	55050928	scroll	5773	55050995	scroll	5214
	165	10.5	-	-	-	55050996	scroll	5659
180	11.6	-	-	-	55050997	scroll	6098	

Nominal capacities @ -10°C Evaporating, 32°C Condensing. R404A

MRC+ LT - LOW TEMPERATURE CONDENSING UNIT

OUTDOOR UNIT							
Model No	Nominal Cooling Duty kW	Single Phase (1ph) Part No.	Compressor Type	Price (£)	Three Phase (3ph) Part No.	Compressor Type	Price (€)
MRC+ LT 40	1.1	55050909	reciprocating	3776	-	-	-
MRC+ LT 50	1.5	55050910	reciprocating	4075	55050912	reciprocating	4096
MRC+ LT 60	2.1	55050911	reciprocating	4123	55050913	reciprocating	4151
MRC+ LT 80	3.2	-	-	-	55050914	scroll	4373
MRC+ LT 90	4.1	-	-	-	55050915	scroll	4709
MRC+ LT 100	4.6	-	-	-	55050916	scroll	5230

Nominal capacities @ -30°C Evaporating, 32°C Condensing. R404A

Accessories

Description	MRC	Part No	Price (€)
Wall Mounting Brackets	15-80	55021100	90
Wall Mounting Brackets	90-180	55021101	125

NB: All accessories are field fit kits

For factory fitted accessories please contact Marstair on **01484 405666**



Authorised User No. 00716

REFRIGERATION

MRC Condensing Units

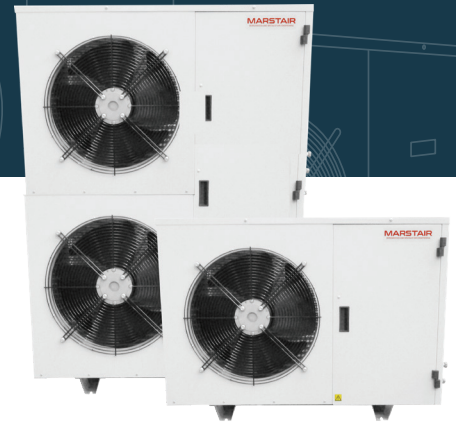

MRC MEDIUM TEMPERATURE CONDENSING UNIT

OUTDOOR UNIT								
Model No	Nominal Cooling Duty kW	Single Phase (1 ph) Part No.	Compressor Type	Price (£)	Three Phase (3 ph) Part No.	Compressor Type	Price (£)	
MRC	15	1.1	55050958	reciprocating	2225	-	-	-
	20	1.4	55050959	reciprocating	2236	-	-	-
	30	2.0	55050960	reciprocating	2246	55050966	reciprocating	2398
	40	2.9	55050961	reciprocating	2398	55050967	reciprocating	2545
	45	2.9	55050925	scroll	2529	-	-	-
	50	3.9	55050962	scroll	2615	55050968	scroll	2713
	60	4.6	55050963	scroll	2637	55050969	scroll	2789
	80	5.5	55050964	scroll	2897	55050970	scroll	3087
	90	6.4	55050965	scroll	3505	55050971	scroll	3657
	100	7.1	55050977	scroll	4080	55050972	scroll	4075
	130	8.1	-	-	-	55050973	scroll	4530
	150	8.8	55050927	scroll	5485	55050974	scroll	4905
	165	10.5	-	-	-	55050975	scroll	5252
	180	11.6	-	-	-	55050976	scroll	5659

Nominal capacities @ -10°C Evaporating, 32°C Condensing, R404A

Accessories

Description	MRC	Part No	Price (€)
Wall Mounting Brackets	15-80	55021100	90
Wall Mounting Brackets	90-180	55021101	125
Kit Panel Insulation	15-40	55021800	90
Kit Panel Insulation	45-80	55021801	100
Kit Panel Insulation	90-100	55021802	110
Kit Panel Insulation	130-165	55021803	125
Kit Panel Insulation	180	55021804	180

NB: All accessories are field fit kits

For factory fitted accessories please contact Marstair on **01484 405666**

A2L SYSTEM MATCH

Box & Wedge Evaporator Medium Temperature



Model No.	Part No.	Duty in kW at 0°C air on evaporating at -10°C Evaporating Temperature using R454C	Duty SC2 in kW at 0°C air on evaporating at -8°C Evaporating Temperature using R454C	Price (€)
MWMT125B	56800039	1.9	1.8	737
MWMT125E	56800040	2.5	2.4	777
MWMT130B	56800041	3.0	2.5	862
MBMT130B	56800003	2.9	2.4	862
MBMT130E	56800004	3.9	3.3	894
MBMT230B	56800005	5.9	4.9	1070
MBMT230C	56800006	6.9	5.8	1183
MBMT230E	56800007	7.6	6.4	1306
MBMT230BE	56800008	8.7	7.3	1424
MBMT430AE	56800009	17.0	14.3	2342

Accessories

Description	Part No.	Price (£)
KIT SMARTCELLA CONTROLLER	56800109	372

COLD ROOM CONDENSING UNITS

A2L SYSTEMMATCH

SMC+ Condensing Units Medium Temperature

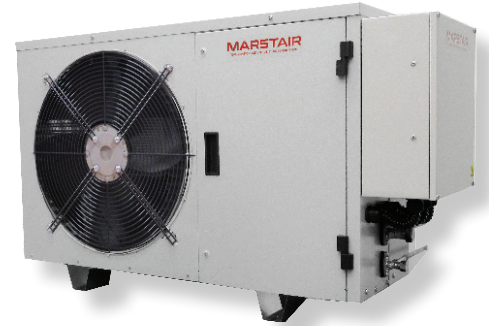

Model No	Nominal Cooling		Single Phase (1 ph)	Compressor Type	Price (€)	Three Phase (3 ph)	Compressor Type	Price (€)	
	Duty kW -10°C Evaporating / 32°C Ambient / 10°C Superheat R454C	Duty kW -8°C Evaporating / 32°C Ambient / 10°C Superheat R454C	Part No.			Part No.			
SMC+	15	1.2	1.3	55030003	Recipricating	4560	-	-	-
	20	1.5	1.6	55030004	Recipricating	4620	-	-	-
	30	1.8	1.9	55030005	Recipricating	4740	-	-	-
	40	2.2	2.4	55030006	Recipricating	4800	55030021	Recipricating	4800
	45	3	3.2	-	-	-	55030022	Scroll	5520
	50	4.2	4.5	-	-	-	55030023	Scroll	5760
	80	5.3	5.7	-	-	-	55030025	Scroll	6000
	90	6	6.5	-	-	-	55030027	Scroll	6240

REFRIGERATION

DRC+ Ducted Condensing Units



DRC+ DUCTED MEDIUM TEMPERATURE CONDENSING UNIT

OUTDOOR UNIT								
Model No	Nominal Cooling Duty kW	Single Phase (1 ph) Part No.	Compressor Type	Price (€)	Three Phase (3 ph) Part No.	Compressor Type	Price (€)	
DRC+	15	1.1	54224059	reciprocating	3643	-	-	
	20	1.4	54224072	reciprocating	3643	-	-	
	30	2.0	54224073	reciprocating	3944	54224078	reciprocating	4095
	40	2.9	54224074	reciprocating	4073	54224079	reciprocating	4186
	50	3.3	54224075	reciprocating	4428	54224080	reciprocating	4627
	60	3.9	54224076	reciprocating	5300	54224081	reciprocating	5434
	80	4.7	54224077	reciprocating	5461	54224082	reciprocating	5569

Nominal cooling capacities @ -10°C Evaporating, 32°C Condensing.

Accessories

Description	DRC(+)	Part No.	Price (£)
Wall Mounting Kit	ALL	53200407	115
Volt Free Relay (including HP switch with alarm output)	ALL	55000395	225
CSR - (hard start 1 phase only)	50	54000405	150
	60-80	54000406	200
Overload for 1 Phase (standard on 3 phase)	20	55023316	140
	30-40	55023317	140
	50-80	55023318	150

NB: All accessories are field fit kits
All units require 2 Duct Transition Pieces and 2 Grilles

For factory fitted accessories please contact Marstair on **01484 405666**

COLD ROOM EVAPORATORS

Box & Wedge Medium Temperature



Medium temperature type evaporators							
Model No.	Type.	Part No.	Duty in kW at 0°C air on evaporating at -8°C (SC2) using R404a	Duty in kW at 0°C air on evaporating at -8°C (SC2) using R449a	Duty in kW at 0°C air on evaporating at -8°C (SC2) using R407a/f	Duty in kW at 0°C air on evaporating at -8°C (SC2) using R452a	Price €
MWMT125B	Wedge	56800039	1.4	1.8	1.8	1.6	737
MWMT125E	Wedge	56800040	1.9	2.4	2.4	2.2	777
MWMT130B	Wedge	56800041	1.9	2.5	2.5	2.3	862
MBMT130B	Box	56800003	1.8	2.4	2.5	2.3	862
MBMT130E	Box	56800004	2.5	3.3	3.4	3	894
MBMT230B	Box	56800005	3.7	4.9	5	4.5	1070
MBMT230C	Box	56800006	4.4	5.8	5.9	5.3	1183
MBMT230E	Box	56800007	4.8	6.4	6.5	5.9	1306
MBMT230BE	Box	56800008	5.5	7.3	7.4	6.7	1424
MBMT430AE	Box	56800009	10.9	14.3	14.7	13.2	2250

COLD ROOM EVAPORATORS

Box & Wedge Low Temperature



Low temperature type evaporators							
Model No.	Type.	Part No.	Duty in kW at -18°C air on evaporating at -25°C (SC3) using R404a	Duty in kW at -18°C air on evaporating at -25°C (SC3) using R449a	Duty in kW at -18°C air on evaporating at -25°C (SC3) using R407a/ff	Duty in kW at -18°C air on evaporating at -25°C (SC3) using R452a	Price €
MWLT130B	Wedge	56800061	1.2	1.7	1.8	1.5	894
MWLT130C	Wedge	56800062	1.5	2.1	2.1	1.9	931
MBLT130E	Box	56800023	1.9	2.6	2.7	2.3	926
MBLT130BE	Box	56800024	2.3	3.1	3.2	2.8	980
MBLT230C	Box	56800025	3.1	4.3	4.5	3.9	1215
MBLT230E	Box	56800026	3.9	5.3	5.5	4.8	1327
MBLT330C	Box	56800027	5	6.9	7.1	6.2	1916
MBLT330E	Box	56800028	6.2	8.4	8.7	7.6	1905

Accessories

Description	Valves Size	Part No.	Price (€)	
Controls and Valves Packages	1 -2.2 kW	3/8"	56800101	530
	2.3 - 4 kW	3/8"	56800102	568
	4 - 6.2 kW	3/8"	56800103	568
	4 - 6.2 kW	1/2"	56800104	555
	6.2 -10 kW	1/2"	56800105	594
	6.2 -10 kW	5/8"	56800106	600

*Control and valve kit includes: Digital Controller, TEV, Solenoid valve and Coil & Room sensors.

CO₂ EVAPORATORS

C02 Concealed Ducted

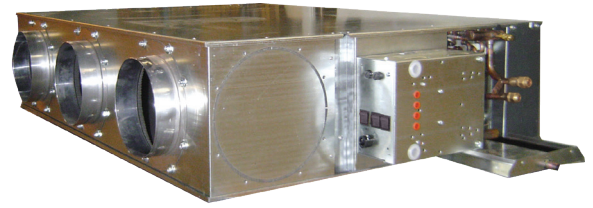

Model				Price (€)	Heating Duty at Air 20°C (kW)				Cooling Duty at Air 23°C (kW)	
					Water Temperatures °C				Evaporating temperature °C	
DXD	Part Number	CO2	LPHW		60 - 30	60-40	65 - 40	50 - 30	7.00	5.00
50	56600039	Y	-	3617	-	-	-	-	4.60	5.50
60	56600040	Y	-	3805	-	-	-	-	5.40	6.40
90	56600041	Y	-	4187	-	-	-	-	9.20	10.80
130	56600042	Y	-	4845	-	-	-	-	10.80	12.50
150	56600043	Y	-	4950	-	-	-	-	12.00	14.80
50	56600044	Y	Y	3805	1.31	2.19	2.30	1.21	4.60	5.50
60	56600045	Y	Y	3999	1.84	2.80	3.33	1.63	5.40	6.40
90	56600046	Y	Y	4469	2.70	4.70	5.64	2.56	9.20	10.80
130	56600047	Y	Y	5226	3.70	5.79	6.94	3.35	10.80	12.50
150	56600048	Y	Y	5414	4.94	6.78	7.50	4.30	12.00	14.80

LPHW Concealed Ducted

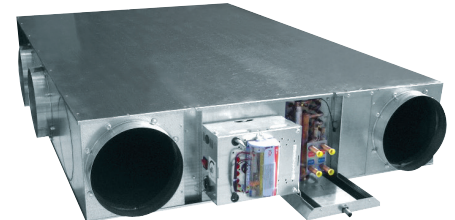

Model				Price (€)	Heating Duty at Air 20°C (kW)				Cooling Duty at Air 23°C (kW)	
					Water Temperatures °C				Evaporating temperature °C	
SAPPHIRE	Part Number	CO2	LPHW		60 - 30	60-40	65 - 40	50 - 30	7.00	5.00
1-1	56625001	-	Y	1261	3.40	5.99	6.25	3.18	-	-
2-2	56625002	-	Y	1483	4.29	7.35	7.69	4.07	-	-
4-3	56625004	-	Y	1870	7.28	12.75	13.34	7.00	-	-
5-4	56625005	-	Y	2074	7.59	13.07	13.68	7.25	-	-
6-4	56625006	-	Y	2279	9.49	15.84	16.59	8.96	-	-
8-5	56625008	-	Y	2738	11.95	19.49	20.40	11.14	-	-

CO₂ EVAPORATORS

DXD Accessories

Description	Unit	Part No	Price (€)	
FFO Electric Heater	2.0 kW	50-60	56600406	335
	2.0 kW	90	56600407	430
	3.0 kW	130	56600408	505
	4.0 kW	150	56600409	595
FFO Return Air Plenum 50	50	56600401	300	
FFO Return Air Plenum 60	60	56600402	320	
FFO Return Air Plenum 90	90	56600403	370	
FFO Return Air Plenum 130	130	56600404	410	
FFO Return Air Plenum 150	150	56600405	445	
Discharge/Inlet Spigot	200mm Diameter	ALL	48002094S	40
	250mm Diameter	ALL	48001985S	60
Return Air Sensor Kit	ALL	97200212	110	
Condensate Pump	ALL	56600423	305	
Programmable Timer	ALL	52500151	160	
Master Slave Control Box	ALL	55600414	300	
Thermostat with dial (RCC30)	ALL	97200211	155	
Thermostat with digital display (RDG100)	ALL	485233	160	
Fitted Carel E2V Valve, Evolution Driver, Transducer and sensor	ALL	N/A	1000	

CO₂ EVAPORATORS

CO₂ Cassette



Model						Price (€)	Heating Duty at Air 20°C (kW)				Cooling Duty at Air 23°C (kW)		CO ₂ Heating Duty
							Water Temperatures °C				Evaporating temperature °C		
CASSETTE	3 Speeds Part Number	0-10V Part Number	CO ₂ Cool	CO ₂ Heat	LPHW		60 - 30	60-40	65 - 40	50 - 30	7.00	5.00	
600 - 20	55233008	55233018	Y	-	Y	2262	1.20	3.00	3.50	1.00	2.40	2.90	-
600 - 20	55233007	55233017	Y	Y	-	2950	-	-	-	-	2.40	2.90	2.70
600 Fascia	55222000		-	-	-	311	-	-	-	-	-	-	-
875- 40	55533007	55533023	Y	Y	-	4441	-	-	-	-	3.30	4.00	4.00
875 - 80	55533018	55533020	Y	-	Y	4335	7.50	12.00	13.00	6.00	5.50	7.00	-
875 - 80	55533014	55533021	Y	Y	-	4759	-	-	-	-	5.50	7.00	10.00
875 - 110	55533015	55533022	-	Y	-	4759	-	-	-	-	-	-	13.00
875 - 140	55533017	55533033	Y	-	-	4202	-	-	-	-	6.80	8.20	-
875 Fascia	55522000		-	-	-	404	-	-	-	-	-	-	-

LPHW Cassette

Model				Price (€)	Heating Duty at Air 20°C (kW)				Cooling Duty at Air 23°C (kW)	
					Water Temperatures °C				Evaporating temperature °C	
CWC	Part Number	CO ₂	LPHW		60 - 30	60-40	65 - 40	50 - 30	7.00	5.00
25	55233010	-	Y	1346	1.20	3.00	3.50	1.00	-	-
45	55233011	-	Y	1750	2.30	5.00	5.50	2.00	-	-
65	55233012	-	Y	2091	3.00	6.50	7.00	2.80	-	-
75	55233013	-	Y	2303	4.00	8.00	8.50	3.50	-	-
600 Fascia	55222000		-	-	311					
95	55533010	-	Y	2626	7.50	11.00	13.00	6.50	-	-
135	55533011	-	Y	3061	10.50	14.00	17.00	9.00	-	-
155	55533012	-	Y	3221	13.00	17.00	20.00	11.00	-	-
875 Fascia	55522000		-	-	404	-	-	-	-	-

CO₂ EVAPORATORS

Accessories

600 Cassette Accessories



Description	Unit	Part No	Price (€)	
Electric Heater	1.0 kW	ALL	55200317	295
	2.0 kW	ALL	55200313	355
Motorised Vanes for heating mode	ALL	97100312	270	
Fresh Air Inlet Spigot 100mm dia	ALL	55200305	140	
Branch Duct Spigot 100mm dia	ALL	55200306	105	
Programmable Timer	ALL	52500151	160	
Discharge Blanking Kit (for 3 way discharge)	ALL	55500316	40	
Return Air Sensor Kit	ALL	97200212	110	
Master Slave Control Box	ALL	55600414	300	
Thermostat with dial (RCC30)	ALL	97200211	155	
Thermostat with digital display (RDG100)	ALL	485233	160	
Fitted Carel E2V Valve, Evolution Driver, Transducer and sensor	ALL	N/A	1000	

875 Cassette Accessories

Description	Unit	Part No	Price (€)	
Electric Heater	1.0 kW	ALL	55500311	355
	2.0 kW	ALL	55500312	440
	3.0 kW	ALL	55500313	495
	4.0 kW 3 ph	ALL	55500314	585
Fresh Air Inlet Spigot 100mm dia	ALL	55200305	140	
Branch Duct Spigot 150mm dia	ALL	55500304	210	
Programmable Timer	ALL	52500151	160	
Discharge Blanking Kit (for 3 way discharge)	ALL	55500316	40	
Return Air Sensor Kit	ALL	97200212	110	
Master Slave Control Box	ALL	55600414	300	
Thermostat with dial (RCC30)	ALL	97200211	155	
Thermostat with digital display (RDG100)	ALL	485233	160	
Fitted Carel E2V Valve, Evolution Driver, Transducer and sensor	ALL	N/A	1000	

CO₂ EVAPORATORS

C02 Wall Mounted WM



Model		Price (€)	CO2 Cooling Duty at Air 23°C (kW)	
			Evaporating temperature °C	
WM	Part Number		7.50	5.00
60	55600069	2676	4.00	5.00

LPHW Wall Mount

Model		Price (€)	Heating Duty at Air 20°C (kW)			
			Water Temperatures °C			
CWM	Part Number		60 - 30	60-40	65 - 40	50 - 30
55	55600072	1343	3.10	5.60	5.80	2.60
75	55600073	1565	4.10	8.00	8.10	3.40
105	55600074	1765	4.90	10.00	10.40	4.10

Accessories

WM Accessories

Description	CWM	Part No.	Price (€)	Heating Duty at Air 20°C (kW)				
				Water Temperatures °C				
				60 - 30	60-40	65 - 40	50 - 30	82-71
LHPW Coil FFO	CO2 60	97300523	165	0.21	0.33	0.34	0.19	1.46
Electric Heater Kit	1.3kW	CO2 60	55600401	275				
Condensate Pump (5m head - with flow protection) Kit		CO2 60	97300446	225				
Programmable Timer Kit		ALL	52500151	160				
Return Air Sensor Kit		ALL	97200212	110				
Thermostat with dial (RCC30)		All	97200211	155				
Thermostat with digital display (RDG100)		All	485233	160				

(FFO = Factory Fitted Option)

Prices for special options - All new special part numbers created at the time of order. For any further information please feel free to contact us.

Marine Condensing Units

Copper / Copper Coil	
MCU+ / MRC+ / CKC	List Price (£)
15	1010
20	1010
30	1010
40	1340
45	1340
50	1340
60	1340
80	1340
90	1585
100	1585
130	2655
150	2655
165	2655
180	3410
200	3410

Stainless Steel Casing FFO	
MCU+ / MRC+ / CKC	List Price (£)
15-40	915
50-80	1165
90-100	1260
130-165	1800
180-200	2330

Accessories

Description	MCU+ / MRC+ / CKC	List Price (£)
60 Hz electrics	ALL	160
3 phase no neutral Transformer	ALL	540
IP65 fan (each)	ALL	950
IP65 electrics	ALL	855
Crankcase Heater	50 - 200	180
Hot Gas Bypass	All	950

Evaporators Accessories

Description	Unit	List Price (£)
Twin Drain	WM	205
60 Hz electrics	ALL	160



Coil Coating Evaporators

Coil Coating	
WM	List Price (£)
60-100	On Application

Coil Coating	
CX(E)	List Price (£)
30-70	On Application

Coil Coating	
Cassette	List Price (£)
CC 600 20 (1 coil)	On Application
CC 600 40 (2 coil)	On Application
CC 600 60 (3 coil)	On Application
CC 875 80 (2 coil)	On Application
CC 875 110 (3 coils)	On Application
CC 875 140 (4 coils)	On Application

Coil Coating Condensing Units Bronz glow

Coil Coating	
MCU+ / MRC+ / CKC	List Price (£)
15-165	510
180-200	885

*Add £75 NETT per order

MARINE/BESPOKE EVAPORATORS, CONDENSERS AND SPLIT AIR CONDITIONING SYSTEMS

SUITABLE FOR A MULTITUDE OF APPLICATIONS SUCH AS COASTAL, EXTREME HIGH AND LOW AMBIENTS, HARSH DUSTY ENVIRONMENTS AND SMALL & LARGE VESSELS.



EVAPORATOR OPTIONS

- Cassette, concealed ducted and wall mounted unit options.
- Copper tubes and fins on coil
- Blygold or electro tinned protective coil coating options
- 50/60Hz
- Twin drain stub condensate tray option



CONDENSING UNIT OPTIONS

- 316 Stainless steel casing
- Copper tubes and fins on coil
- Blygold or electro tinned protective coil coating options
- 3 phase no neutral electrics
- 50/60Hz
- Voltage selection transformer
- IP65 rating fans and electrical enclosures
- Hotgas bypass valve option for extreme low ambient conditions -40°C
- R134A option for extreme high ambient conditions +55°C
- Coil guards
- Compressor crankcase heater
- High wind support brackets

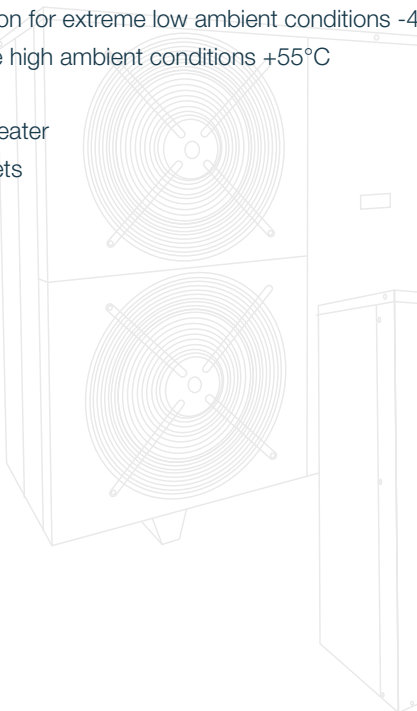

ATEX AND OFFSHORE

MARSTAIR OFFER A WIDE RANGE OF ATEX AIR CONDITIONING AND REFRIGERATION SYSTEMS SPECIFICALLY DESIGNED FOR HAZARDOUS (ZONE 1 & ZONE 2) ENVIRONMENTS.



MCUA ZONE 1 CONDENSERS & MMC SAFE AREA COMPRESSOR UNITS

The Compact MCUA condenser is designed to operate in a 3 way split system with the Marstair MMC safe area compressor units and the wide range of Marstair air conditioning and refrigeration evaporator options.

- 50/60Hz
- Wide voltage range options
- Wide range of refrigerant options including new low GWP R448 and R449
- Large ambient range -40°C to +55°C
- Compact design

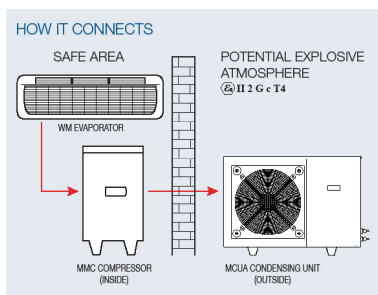

- Robust Emerson Compressors
- Wide range of refrigerant options including new low GWP R448 and R449
- Hotgas bypass valve option for extreme low ambient conditions -40°C
- R134A option for extreme high ambient conditions +55°C
- 3 phase no neutral electrics
- 50/60Hz
- Voltage selection transformer



MCU+ ZONE 2 CONDENSING UNITS

The MCU+ Zone 2 condensing units offer all the options of the Marstair Marine range of condensing units but are also suitable for hazardous environments.

- 316 Stainless steel casing
- Copper tubes and fins on coil
- Blygold or electro tinned protective coil coating options
- 3 phase no neutral electrics
- 50/60Hz
- Voltage selection transformer
- IP65 rating fans and electrical enclosures
- Hotgas bypass valve option for extreme low ambient conditions -40°C
- R134A option for extreme high ambient conditions +55°C
- Coil guards
- Compressor crankcase heater
- High wind support brackets

ZONE 2 WM WALL MOUNTED EVAPORATORS

The Zone 2 WM Wall mounted evaporators designed for hazardous environment air conditioning applications such as flammable liquid storage facilities.

- Blygold or electro tinned protective coil coating options
- 50/60Hz
- Twin drain stub condensate tray option

ALL MARINE REFRIGERATION SYSTEMS ARE PRICED ON APPLICATION PLEASE CONTACT MARSTAIR ON **01484 405666**

MARSTAIR

REFRIGERATION AND SPECIALIST AIR CONDITIONING

PROCESS/MATERIAL COOLING • CLOSE CONTROL • REFRIGERATION

TEV Ltd, Marstair Division,
Armytage Road, Brighouse,
West Yorkshire, HD6 1QF.

T: +44 (0) 1484 405666
F: +44 (0) 870 606 4850
E: sales@marstair.com

WWW.MARSTAIR.COM

A division of TEV Limited

To view our Terms and Conditions visit

www.tevlimited.com/terms.html

In partnership with

QUARTZ
FAN COILS AND HVAC

