

## TECHNICAL MANUAL

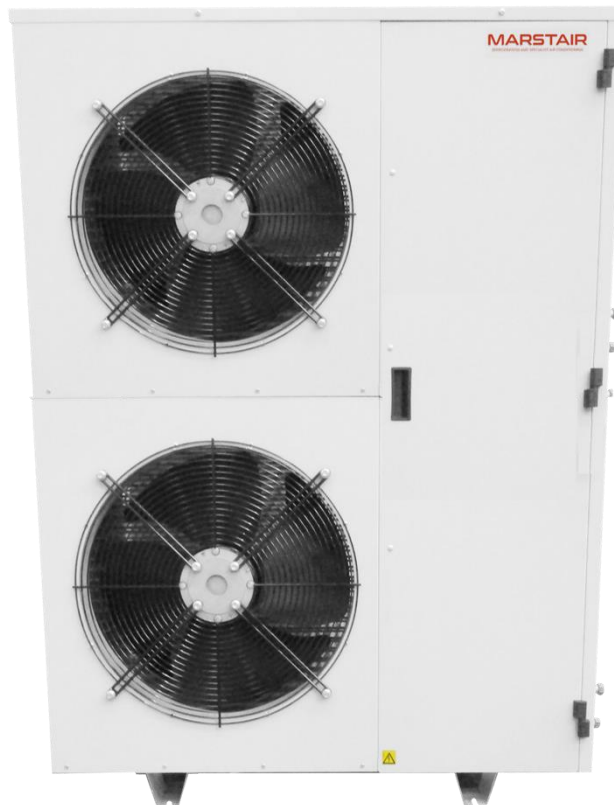

## CKC CONDENSING UNITS

## INDEX

<b><u>CONTENTS</u></b>	<b><u>PAGE</u></b>
UNIT PART NUMBERS, FEATURES & OPTIONS	3
KITS	4
DIMENSIONS & WEIGHTS (packed & unpacked)	4
SPECIFICATION	5
PERFORMANCE DATA	6
MOUNTING CKC, DIMENSIONS & WEIGHTS CKC	7
PIPEWORK	9
PIPE SIZES, CONNECTING THE UNITS & EVACUATING	10
ELECTRICAL	12
WIRING DIAGRAMS	13
REFRIGERANT	17
COMPONENT IDENTIFICATION CKC	20
COMMISSIONING CHECK LIST	21

## GENERAL

1. TEV Ltd recommend that personnel working on this equipment be skilled and fully conversant with the appropriate Air Conditioning, Refrigeration and Electrical practices and have sound knowledge of current Industrial Safe Working practices.
2. These units are supplied with a holding charge of **Oxygen free Nitrogen** and polyolester oil. Do not mix oils or refrigerants.
3. These units contain live electrical components, moving parts and refrigerant under pressure. Always site out of reach of children and protect from vandalism.
4. The data plate only gives information for the outdoor unit. For system details add input power and current of indoor and outdoor unit, including any heater load.
5. FUSES – for recommended fuse size see indoor unit instructions

NOTE: These units are not fitted with an expansion device.

## PART NUMBERS

MODEL	SINGLE (1ph) PHASE	THREE PHASE (3ph) PART NUMBER
CKC 15 1/50	55050769	-
CKC 20 1/50	55050720	-
CKC 30 1/50	55050730	55050774
CKC 40 1/50	55050741	55050775
CKC 50 1/50	55050722	55050776
CKC 60 1/50	55050740	55050777
CKC 80 1/50	55050723	55050724
CKC 90 1/50	55050771	55050778
CKC 100 3/50	-	55050779
CKC 130 3/50	-	55050780
CKC 150 3/50	-	55050781
CKC 165 3/50	-	55050782
CKC 180 3/50	-	55050783
CKC 200 3/50	-	55050784

### Expansion Device Part Numbers

MODEL	(1ph) PART NUMBER
CKC 15 1/50	55023323
CKC 20 1/50	55023323
CKC 30 1/50	55023324
CKC 40 1/50	55023325
CKC 50 1/50	55023327
CKC 60 1/50	55023328
CKC 80 1/50	55023329
CKC 90 1/50	55023330
CKC 100 3/50	55023331
CKC 130 3/50	55023332
CKC 150 3/50	55023333
CKC 165 3/50	55023334
CKC 180 3/50	55023335
CKC 200 3/50	-

## FEATURES AND OPTIONS

DESCRIPTION	CKC
Easy access for installation and service	✓
Suction and liquid services valves	✓
Expansion device (orifice type)	•
Capacitor start relay 1ph	•
PTC resistor 1ph	•
Head pressure control	✓
LP cut-out auto	✓
HP cut-out auto	✓
Isolator	•
3 minute start time delay	✓
Wall mount brackets	•
Contactora	✓
Over load (standard on 3ph)	✓
Low ambient start	✓
✓ = Standard   • = Option	

## KITS

<b>CKC</b>		
<b>DESCRIPTION</b>	<b>MODEL</b>	<b>PART NUMBER</b>
Pressure switch (HP manual)	All	55000398
Volt free relay	All	55000395
Wall mount brackets	15-80	55021100
	90-200	55021101
Overload (standard on 3ph)	15	55000409
	20-30	55000410
	40-60	55000446
	80-90	55000449
PTC (hard start 1ph)	15-40	55000412
CSR (hard start 1ph)	15,20,40	55000414
	30	55000415
Isolator for remote mounting	1ph 15-60	55000419
	1ph 80-90	55000418
	3ph All	55000419
Compressor jacket	Reciprocating 15-40	55000454
	Scroll 50-80	55000455
	Scroll 90-180	55000456
	Scroll 200	55000457

## DIMENSIONS & WEIGHTS CKC

### UNPACKED

#### CKC CONDENSING UNITS

<b>MODEL</b>	<b>15</b>	<b>20</b>	<b>30</b>	<b>40</b>	<b>50</b>	<b>60</b>	<b>80</b>	<b>90</b>	<b>100</b>	<b>130</b>	<b>150</b>	<b>165</b>	<b>180</b>	<b>200</b>
<b>HEIGHT</b>	620	620	620	620	720	720	720	820	820	1080	1080	1080	1275	1275
<b>WIDTH mm</b>	900	900	900	900	1000	1000	1000	1000	1000	1000	1000	1000	1100	1100
<b>DEPTH mm</b>	300	300	300	300	350	350	350	350	350	425	425	425	425	425
<b>1 Ph kg</b>	45	46	48	53	64	65	66	76	-	-	-	-	-	-
<b>3 Ph kg</b>	-	-	48	53	62	63	64	73	81	101	103	103	118	173

### PACKED

#### CKC CONDENSING UNITS

<b>MODEL</b>	<b>15</b>	<b>20</b>	<b>30</b>	<b>40</b>	<b>50</b>	<b>60</b>	<b>80</b>	<b>90</b>	<b>100</b>	<b>130</b>	<b>150</b>	<b>165</b>	<b>180</b>	<b>200</b>
<b>HEIGHT mm</b>	620	620	620	620	720	720	720	820	820	1080	1080	1080	1280	1280
<b>WIDTH mm</b>	980	980	980	980	1080	1080	1080	1090	1090	1090	1090	1090	1215	1215
<b>DEPTH mm</b>	340	340	340	340	390	390	390	390	390	465	465	465	465	465
<b>1 Ph kg</b>	47	48	50	55	66	67	68	78	-	-	-	-	-	-
<b>3 Ph kg</b>	-	-	50	55	64	65	66	75	83	105	107	107	123	178

## SPECIFICATION DETAILS

<b>CKC</b>		<b>15</b>	<b>20</b>	<b>30</b>	<b>40</b>	<b>50</b>	<b>60</b>	<b>80</b>	<b>90</b>	<b>100</b>	<b>130</b>	<b>150</b>	<b>165</b>	<b>180</b>	<b>200</b>
Nominal cooling capacity	kW	2.5	2.8	3.7	4.2	5.8	7.0	7.4	8.2	10.9	12.4	13.9	14.7	17.1	19.9
Operating weight kg	1Ph	45	46	48	53	64	65	66	76	-	-	-	-	-	-
	3Ph	-	-	48	53	62	63	64	73	81	101	103	103	118	173

### 1 Ph (230V 50Hz)

Power (nominal)	kW	1.1	1.6	1.6	2.1	2.0	2.4	3.0	4.2	-	-	-	-	-	-
Starting current LRA	A	23	28	36	50	58	61	76	114	-	-	-	-	-	-
Nominal current FLA	A	5.9	6.9	8.1	10.2	8.9	9.8	11.5	16.9	-	-	-	-	-	-

### 3Ph (400v 50Hz)

Power (nominal)	kW	-	-	1.6	2.0	1.9	2.4	3.0	4.1	4.3	4.4	5.3	6.0	7.0	9.4
Starting current LRA	A	-	-	18	22	26	32	40	48	51	62	68	71	71	98
Nominal current FLA	A	-	-	3.6	4.8	4.2	4.2	4.9	7.1	7.2	7.7	8.7	9.5	11.9	16.9

### Sound Pressure Levels (SPL) at 10m distance in free field conditions.

Fan speed max	dBA	39.2	39.2	39.3	39.2	38.9	39.3	38.7	42.2	43.0	41.9	42.2	42.2	42.9	43.2
---------------	-----	------	------	------	------	------	------	------	------	------	------	------	------	------	------

### Condenser fan (1Ph 230V 50Hz)

Airflow (max speed)	m <sup>3</sup> /s	0.97	0.97	0.97	0.97	0.97	0.97	0.97	0.97	0.97	1.85	1.85	1.85	1.85	1.85
Fan motor rating	kW	0.13	0.13	0.13	0.13	0.13	0.13	0.13	0.24	0.24	2x0.13	2x0.13	2x0.13	2x0.24	2x0.24
Nominal current FLA	A	0.6	0.6	0.6	0.6	0.6	0.6	0.6	1.0	1.0	2x0.60	2x0.60	2x0.60	2x1.00	2x1.00
Fans: No. x diameter	#x mm	1x457	1x457	1x457	1x457	1x457	1x457	1x457	1x508	2x457	2x457	2x457	2x457	2x508	2x508
Fans max speed	r.p.m	760	760	760	760	910	910	910	950	950	910	910	910	950	950

**CKC 15 – 200 CAPACITIES**

MODEL	AIR ON TO CONDENSER °C	SATURATED SUCTION TEMPERATURE °C											
		-2.5		0		2.5		5		7.5		10	
		COOLING CAPACITY AND POWER INPUT KW											
		CAP.	POWER	CAP.	POWER	CAP.	POWER	CAP.	POWER	CAP.	POWER	CAP.	POWER
CKC 15	25	1.93	0.69	2.14	0.70	2.35	0.70	2.55	0.71	2.76	0.72	2.96	0.72
	30	1.81	0.74	2.01	0.75	2.21	0.76	2.41	0.77	2.61	0.78	2.81	0.79
	35	1.69	0.79	1.89	0.80	2.08	0.81	2.27	0.83	2.46	0.84	2.65	0.86
	40	1.58	0.84	1.76	0.86	1.95	0.88	2.13	0.90	2.32	0.91	2.50	0.93
	45	1.46	0.90	1.64	0.92	1.82	0.94	2.00	0.97	2.18	0.99	2.36	1.01
CKC 20	25	2.25	0.80	2.49	0.81	2.71	0.81	2.96	0.82	3.22	0.84	3.49	0.85
	30	2.08	0.84	2.31	0.86	2.54	0.87	2.78	0.89	3.01	0.90	3.26	0.92
	35	1.94	0.90	2.16	0.92	2.38	0.93	2.61	0.95	2.84	0.97	3.05	0.98
	40	1.83	0.98	2.04	0.99	2.25	1.01	2.46	1.03	2.66	1.05	2.86	1.06
	45	1.73	1.07	1.92	1.08	2.11	1.09	2.30	1.11	2.49	1.13	2.68	1.15
CKC 30	25	2.87	1.02	3.22	1.05	3.53	1.06	3.74	1.04	4.12	1.07	4.49	1.10
	30	2.71	1.10	3.06	1.13	3.27	1.12	3.51	1.12	3.84	1.15	4.19	1.18
	35	2.59	1.20	2.82	1.20	3.03	1.19	3.36	1.23	3.68	1.26	3.79	1.22
	40	2.38	1.27	2.17	1.32	2.80	1.26	3.12	1.31	3.32	1.31	3.62	1.35
	45	2.11	1.30	2.43	1.36	2.53	1.31	2.84	1.37				
CKC 40	25	3.38	1.13	3.70	1.15	4.02	1.16	4.35	1.18	4.67	1.19	5.00	1.21
	30	3.19	1.22	3.50	1.24	3.81	1.26	4.11	1.28	4.42	1.30	4.73	1.32
	35	3.01	1.31	3.30	1.33	3.59	1.36	3.88	1.38	4.17	1.41	4.46	1.43
	40	2.84	1.40	3.11	1.43	3.37	1.47	3.63	1.50	3.89	1.53	4.15	1.56
	45	2.68	1.51	2.91	1.55	3.15	1.58	3.38	1.62	3.61	1.66	3.85	1.70
CKC 50	25	4.57	1.87	5.09	2.03	5.51	2.14	5.97	2.25	6.41	2.38	6.79	2.51
	30	4.34	1.95	4.75	2.09	5.25	2.19	5.63	2.32	6.04	2.45	6.49	2.58
	35	3.94	2.00	4.42	2.13	4.91	2.24	5.29	2.36	5.75	2.49	6.09	2.65
	40	3.76	2.05	4.22	2.18	4.58	2.29	5.04	2.41	5.39	2.58	5.69	2.74
	45	3.50	2.12	3.93	2.22	4.37	2.35	4.69	2.48				
CKC 60	25	5.43	2.22	6.02	2.27	6.61	2.31	7.21	2.37	7.80	2.42	8.39	2.47
	30	5.06	2.46	5.64	2.51	6.22	2.56	6.80	2.62	7.39	2.67	7.97	2.73
	35	4.77	2.72	5.33	2.78	5.89	2.83	6.45	2.89	7.01	2.95	7.57	3.01
	40	4.39	3.01	4.91	3.07	5.43	3.13	5.95	3.19	6.47	3.26	6.99	3.32
	45	4.02	3.32	4.49	3.40	4.97	3.46	5.45	3.53	5.93	3.60		
CKC 80	25	6.07	2.26	6.64	2.31	7.21	2.37	7.79	2.42	8.36	2.47	8.93	2.53
	30	5.68	2.49	6.23	2.54	6.77	2.60	7.32	2.66	7.87	2.71	8.42	2.77
	35	5.28	2.72	5.81	2.78	6.33	2.83	6.86	2.89	7.38	2.95	7.91	3.01
	40	4.90	3.03	5.39	3.10	5.88	3.16	6.37	3.23	6.86	3.29	7.35	3.36
	45	4.52	3.35	4.97	3.42	5.43	3.49	5.88	3.56	6.33	3.63		
CKC 90	25	7.16	2.89	7.71	2.95	8.26	3.01	8.81	3.06	9.36	3.12	9.91	3.18
	30	6.69	3.17	7.21	3.24	7.74	3.30	8.27	3.36	8.79	3.42	9.32	3.48
	35	6.22	3.46	6.72	3.52	7.22	3.59	7.72	3.65	8.23	3.72	8.73	3.78
	40	5.80	3.79	6.27	3.86	6.74	3.93	7.22	4.00	7.69	4.07	8.17	4.14
	45	5.38	4.12	5.82	4.20	6.27	4.27	6.71	4.34	7.16	4.42	7.60	4.49
CKC 100	25	7.87	3.18	9.10	3.42	10.40	3.66	11.52	3.87	12.61	3.87	13.83	3.86
	30	7.60	3.23	8.73	3.88	9.68	3.81	10.71	4.05	11.66	4.18	12.71	4.29
	35	7.00	3.24	8.06	3.56	9.03	3.87	9.92	4.13	10.91	4.31	11.89	4.52
	40	6.17	3.16	7.12	3.54	8.14	3.86	8.91	4.17	9.86	4.47	10.80	4.75
	45	5.12	2.95	6.18	3.47	7.07	3.89	7.89	4.25				
CKC 130	25	9.69	3.14	10.71	3.46	11.72	3.73	12.76	4.01	13.71	4.28	14.56	4.54
	30	9.09	3.16	10.07	3.46	11.11	3.74	12.12	4.08	13.05	4.36	13.93	4.68
	35	8.27	3.27	9.32	3.61	10.27	3.91	11.34	4.25	12.41	4.56	13.29	4.91
	40	7.61	3.29	8.58	3.65	9.54	4.01	10.44	4.31	11.46	4.68		
	45	6.89	3.34	7.63	3.68	8.68	4.09						
CKC 150	25	11.06	3.73	12.26	4.13	13.26	4.46	14.30	4.82	15.24	5.15	16.19	5.47
	30	10.42	3.75	11.52	4.14	12.56	4.48	13.57	4.88	14.56	5.24	15.48	5.63
	35	9.46	3.89	10.59	4.32	11.61	4.68	12.69	5.08	13.77	5.47	14.77	5.90
	40	8.70	3.90	9.79	4.35	10.76	4.78	11.67	5.15				
	45	7.90	3.98	8.89	4.40								
CKC 165	25	11.97	4.13	13.30	4.57	14.29	4.95	15.32	5.36	16.26	5.73	17.28	6.09
	30	11.31	4.15	12.49	4.59	13.52	4.98	14.54	5.42	15.57	5.82	16.51	6.26
	35	10.26	4.30	11.44	4.79	12.51	5.19	13.59	5.64	14.67	6.08	15.75	6.56
	40	9.43	4.31	10.60	4.81	11.58	5.29	12.49	5.17				
	45	8.57	4.41										
CKC 180	25	13.42	4.71	14.97	5.12	16.28	5.45	17.63	5.79	18.86	6.13	20.27	6.47
	30	12.74	4.75	14.13	5.16	15.39	5.51	16.76	5.90	18.08	6.26	19.34	6.64
	35	11.52	4.94	12.94	5.38	14.34	5.76	15.67	6.16	17.12	6.56	18.51	6.98
	40	10.63	4.96	11.97	5.44	13.28	5.89	14.43	6.26	15.95	6.74	17.31	7.18
	45	9.72	5.10	10.95	5.61	12.17	6.09	13.31	6.49	14.63	6.98		
CKC 200	25	15.28	5.37	16.96	5.90	18.96	6.47	21.12	6.87	22.34	7.28	23.48	7.65
	30	14.42	5.41	16.01	5.92	17.73	6.41	19.75	6.96	21.18	7.40	22.52	7.88
	35	13.13	5.51	14.68	6.17	16.49	6.68	18.30	7.23	19.88	7.74	21.48	8.27
	40	12.03	5.62	13.59	6.24	15.13	6.82	16.58	7.31	18.33	7.92		
	45	10.99	5.78	12.36	6.42	13.80	7.03						

**NOTE: OPERATION IN THE SHADED AREAS OF THE TABLE WILL RESULT IN UNACCEPTABLY HIGH CONDENSING TEMPERATURE AND SHOULD BE AVOIDED.**

## MOUNTING CKC

These units are designed to stand on a flat surface. If the unit is to be wall mounted the following kits are available.

KIT	CKC 15-80	CKC 90-200
<b>Mounting Bracket</b>	55021100	55021101

Whether floor or wall mounted, it is essential that the mounting surface is capable of supporting the unit weight. Leave space around the unit for air circulation and access for installation and maintenance.

### CKC 15-100

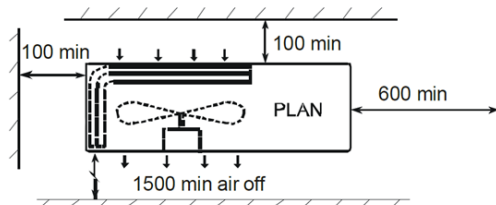

### CKC 130-200

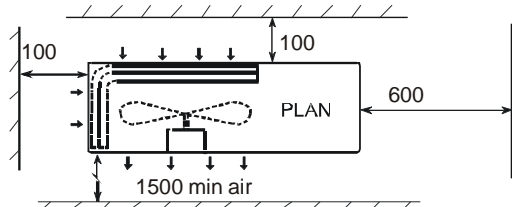

Dimensions in mm.

## DIMENSIONS & WEIGHTS CKC

CKC 15-100 (Dimensions in mm.)

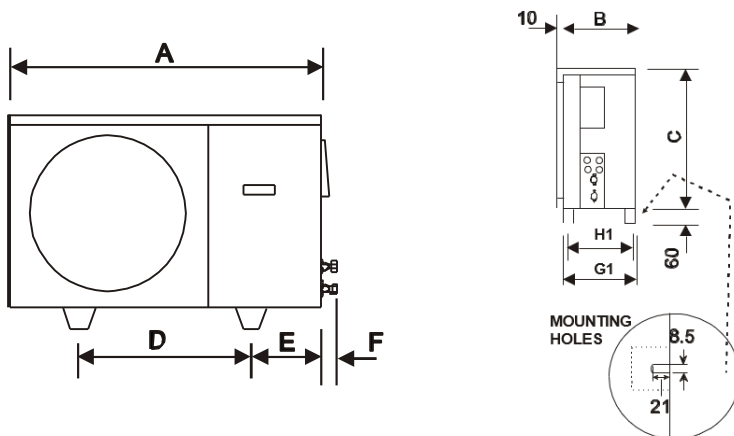

MODEL	A	B	C	D	E	F	G1	H1	Weight (kg)	
									1 Ph	3 Ph
CKC 15	900	300	560	525	185	60	295	275	45	--
CKC 20	900	300	560	525	185	60	295	275	46	--
CKC 30	900	300	560	525	185	60	295	275	48	48
CKC 40	900	300	560	525	185	60	295	275	53	53
CKC 50	1000	350	660	570	213	60	345	325	64	62
CKC 60	1000	350	660	570	213	60	345	325	65	63
CKC 80	1000	350	660	570	213	60	345	325	66	64
CKC 90	1000	350	760	495	250	70	345	325	76	73
CKC 100	1000	350	760	495	250	70	345	325	--	81

**CKC 130 – 200** (Dimensions in mm.)

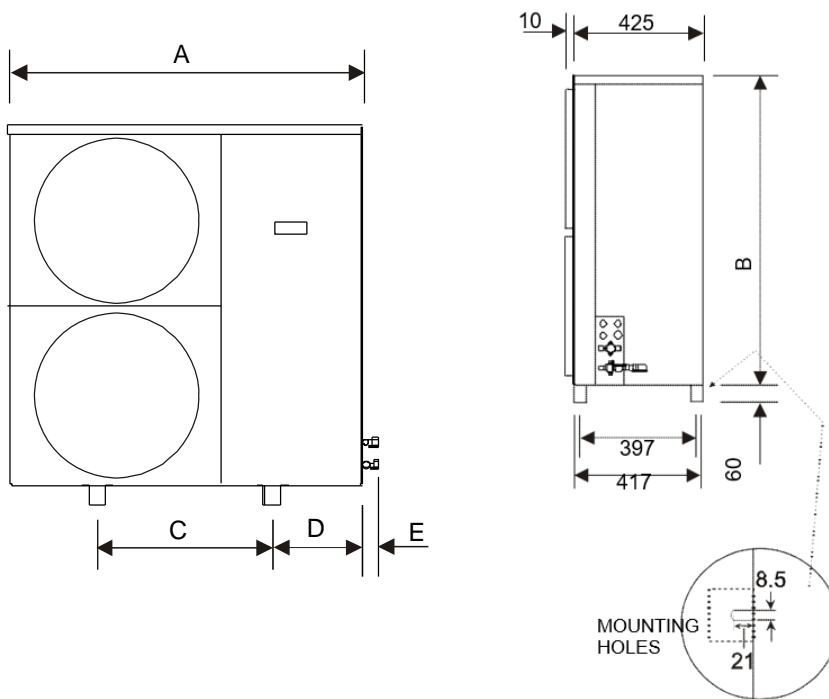

MODEL	A	B	C	D	E	Weight (kg)
CKC 130	1000	1020	495	251	100	101
CKC 150	1000	1020	495	251	100	103
CKC 165	1000	1020	495	251	100	103
CKC 180	1100	1215	675	211	95	118
CKC 200	1100	1215	675	211	95	173

## PIPEWORK

Supplied male flare connections (sizes in inches)

Model	CKC													
Size	15	20	30	40	50	60	80	90	100	130	150	165	180	200
Expansion	3/8	3/8	3/8	3/8	3/8	3/8	1/2	1/2	1/2	1/2	1/2	1/2	1/2	1/2
Suction	3/8	3/8	1/2	1/2	1/2	5/8	5/8	5/8	3/4	3/4	3/4	3/4	7/8*	7/8*

\* Brazed connections

### MAXIMUM PIPE RUNS

Liquid lines (CD3 on cellar coolers)  
45m maximum (CKC 15-20 = 20M) including 20m lift.

Expansion line with expansion device fitted on CKC liquid service valve.  
80m maximum (CKC 15-20 = 50M) including 20m lift.

There will be no significant loss of capacity for extended pipe runs provided pipes are correctly sized and the correct restrictor is fitted.

### CALCULATING EQUIVALENT LENGTHS

The effects of bends and fittings must be taken into account. The table on top of page 5 covers the fittings most likely to be encountered in installation.

**ACTUAL PIPE LENGTH + TOTAL EQUIVALENT FITTING LENGTHS = TOTAL EQUIVALENT LENGTH**

**FITTING LOSSES** in equivalent straight lengths of pipes (m)

FITTING	PIPE SIZE (outside diameter in inches)						INSTALLERS TABLE	
	3/8	1/2	5/8	3/4	7/8	1 1/8	Nº OF FITTINGS	EFFECTIVE LENGTH
45° Bend	0.12	0.15	0.18	0.21	0.24	0.30		
90° Bend R/d = 1	0.37	0.43	0.49	0.55	0.61	0.79		
90° Bend R/d = 2	0.24	0.27	0.30	0.37	0.43	0.52		
180° Bend C/d = 1	0.73	0.91	1.10	1.28	1.46	1.83		
180° Bend C/d = 2	0.46	0.55	0.64	0.76	0.85	1.07		
90° Elbow	0.67	0.85	1.04	1.25	1.46	1.89		
<b>R = Radius of bend</b>	<b>d = Diameter of tube</b>		<b>C = Centres of bend</b>			<b>TOTAL =</b>		

Pipe sizes are based on:

Minimum of 2.5 m/s (500 fpm) suction gas velocity for horizontal or downflow.

Minimum of 5.0 m/s (1000 fpm) suction gas velocity for upflow.

Maximum of 20.0 m/s (4000 fpm) suction gas.

Where vertical risers exceed 3m, oil traps must be formed in the pipe. This will help ensure that oil returns to the compressor. Typically fit an oil trap every 3m with a trap at the bottom of the riser.

### GOOD PRACTICE

- Keep pipe runs as short as possible.
- Avoid sharp bends
- Fully insulate both suction and expansion including mechanical connections
- Try to avoid running pipes through hot areas.

**PIPE SIZES – Liquid Line**

UNIT SIZE	MAXIMUM LENGTH OF EQUIVALENT SUCTION LINE PIPE SIZES (m)							LIQUID LINE		
	$\frac{3}{8}$	$\frac{1}{2}$	$\frac{5}{8}$	$\frac{3}{4}$	$\frac{7}{8}$	$1\frac{1}{8}$	$1\frac{3}{8}$	$\frac{3}{8}$	$\frac{1}{2}$	$\frac{5}{8}$
15	7.5	20						20		
20	7.5	20						20		
30		15	45					45		
40		10	36	45				7.5	45	
50		7.5	18	45				7.5	45	
60			14	36	45			7.5	45	
80			11	30	45				45	
90			10	25	45				20	45
100			7.5	22	45				15	45
130				15	30	45			12	45
150				12	27	45			8	45
165				8	18	45			7.5	45
180				7.5	16	45			7.5	45
200					15	45			7.5	45

**PIPE SIZES – Expansion Line**

UNIT SIZE	MAXIMUM LENGTH OF EQUIVALENT SUCTION LINE PIPE SIZES (m)							EXPANSION LINES			
	$\frac{3}{8}$	$\frac{1}{2}$	$\frac{5}{8}$	$\frac{3}{4}$	$\frac{7}{8}$	$1\frac{1}{8}$	$1\frac{3}{8}$	$\frac{3}{8}$	$\frac{1}{2}$	$\frac{5}{8}$	$\frac{3}{4}$
15	7.5	30	50					50			
20	7.5	23	50					50			
30		15	50	80				50	80		
40		10	36	80				7.5	80		
50		7.5	18	50	80			7.5	50	80	
60			14	36	80			7.5	50	80	
80			11	30	80				50	80	
90			10	25	55	80			20	80	
100			7.5	22	45	80			15	80	
130				15	30	80			12	60	80
150				12	27	80			8	50	80
165				8	18	60	80		7.5	40	80
180				7.5	16	55	80		7.5	35	80
200					15	50	80		7.5	30	80

## RESTRICTORS

Outdoor units (cool only) have optional kit expansion assemblies with cooling restrictors fitted.

CKC	15	20	30	40	45	50	60	80	90	100	130	150	165	180	200
Restrictor	0.033	0.033	0.040	0.044	0.046	0.050	0.052	0.057	0.063	0.068	0.071	0.080	0.082	N/A	N/A

## CONNECTING THE UNITS

1. Ensure both service valves on the unit are closed (clockwise) before commencing installation.
2. If a expansion assembly requires cleaning:
  - a. Remove the entire expansion assembly from the outdoor unit.
  - b. Split the expansion assembly in the middle and remove the existing restrictor.
  - c. Drop the new restrictor vertically into the field connector.
  - d. Reassemble in the vertical plane (field connector lowest) when reassembled the restrictor can be heard to be free to move if the assembly is shaken.
  - e. Refit the expansion assembly.
3. Connecting the pipework:
  - a. Remove the flare nuts from the suction service valve and the expansion device as appropriate.
  - b. Ensure that both the suction and expansion lines are fully insulated.
  - c. Place the flare nuts over the incoming pipework and flare the pipe ends.
  - d. Connect the pipework between the units. Do not leave pipes ends, valves etc open to the atmosphere. Always use 2 spanners when tightening the flare nuts to avoid twisting the pipes. Use a small amount of refrigerant oil on the mating surfaces.
  - e. Sight glasses and filters driers are not necessary, but if required should be fitted between the outdoor unit liquid shut off valve and the expansion device on the CKC units.
  - f. CKC 180 & 200 have a 7/8" suction pipe with brazed connections. Use a protective shield to avoid scorching the side panel.

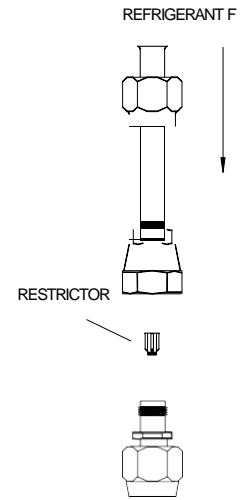

## EVACUATING

With the valves closed, connect a vacuum pump to the service ports on the outdoor unit valves. Evacuate the interconnecting pipework and indoor unit to 1000 microns (1 Torr) or better. Allow this to be held for a minimum of 15 minutes.

## ELECTRICAL

The installer supplies mains, control and interconnecting cables: equipment must be earthed. Wiring must be carried out in accordance with local and national codes.

**Interconnecting wiring diagrams are in the indoor unit installation instructions.**

Mains supply cables must be size compatible with the recommended fuse (see indoor unit instructions).

An all pole isolator switch should be positioned within easy reach of the indoor unit.

Cable clamps for use with stranded cables are supplied in units 15 - 90 and should be used to secure incoming/outgoing cables. Installers must supply a method of securing solid sheathed cables.

**THREE PHASE UNITS WITH SCROLL COMPRESSORS:**

On 3 Ph units sizes 50 - 200 it is possible for the scroll compressor to run backwards.

This becomes obvious on start up - the compressor will not develop a normal running pressure differential and the top will not become warm: it may be excessively noisy. If this happens, switch off the mains power and exchange the two supply phases **not** connected to the indoor unit. This will correct the rotation.

**ISOLATOR SWITCHES:**

On 3 phase systems ensure that the neutral contact of the isolator switch is an early make, late break type.

This applies to all switches in the supply line. **Failure to observe this could result in damage to the electronic board. If in doubt, do not switch the neutral but connect it solidly.**

**WIRING**

1. Cable entry for the outdoor unit electrics is through the cabinet to a terminal block.
2. Ensure that all connections are secure and that both units are earthed.
3. CKC fan motors have a single speed and are ready for use at all outdoor temperatures.

**NOTE:** The CKC wiring diagram can be found on the inside of the front panel.

1PH FUSE SIZE														
CKC	15	20	30	40	50	60	80	90	100	130	150	165	180	200
FUSE	16	16	16	20	16	20	25	32	-	-	-	-	-	-

3PH FUSE SIZE												
CKC	30	40	50	60	80	90	100	130	150	165	180	200
FUSE	10	10	10	10	10	16	16	16	20	20	25	32

**WHEN INSTALLATION IS COMPLETE CHECK THE FOLLOWING:**

1. All pipework and joints for leakage.
2. Pipework and fittings are suitably insulated.
3. All fasteners are secure and the fan rotates freely.

# WIRING DIAGRAMS

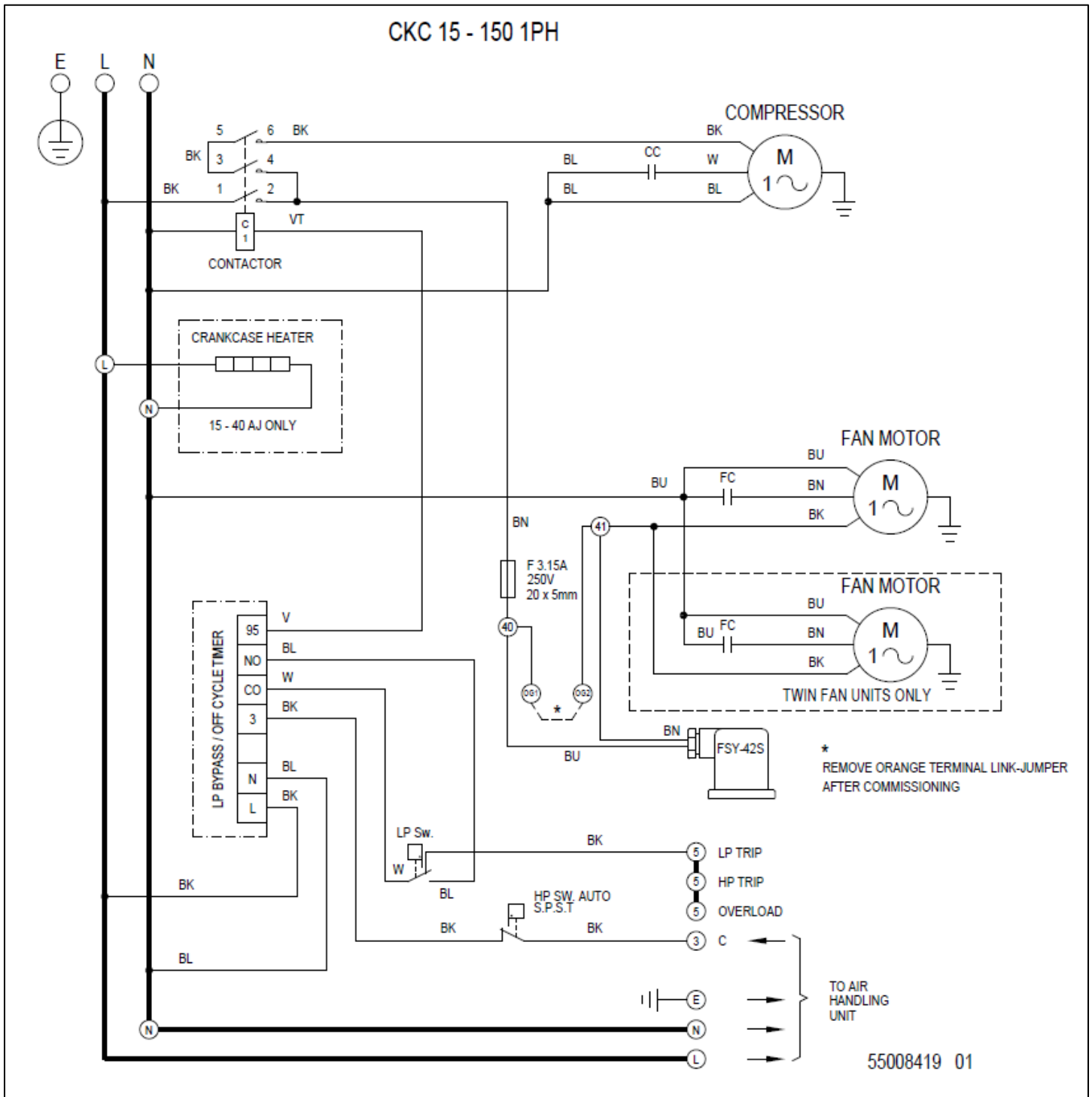

CKC 30 - 100 3PH

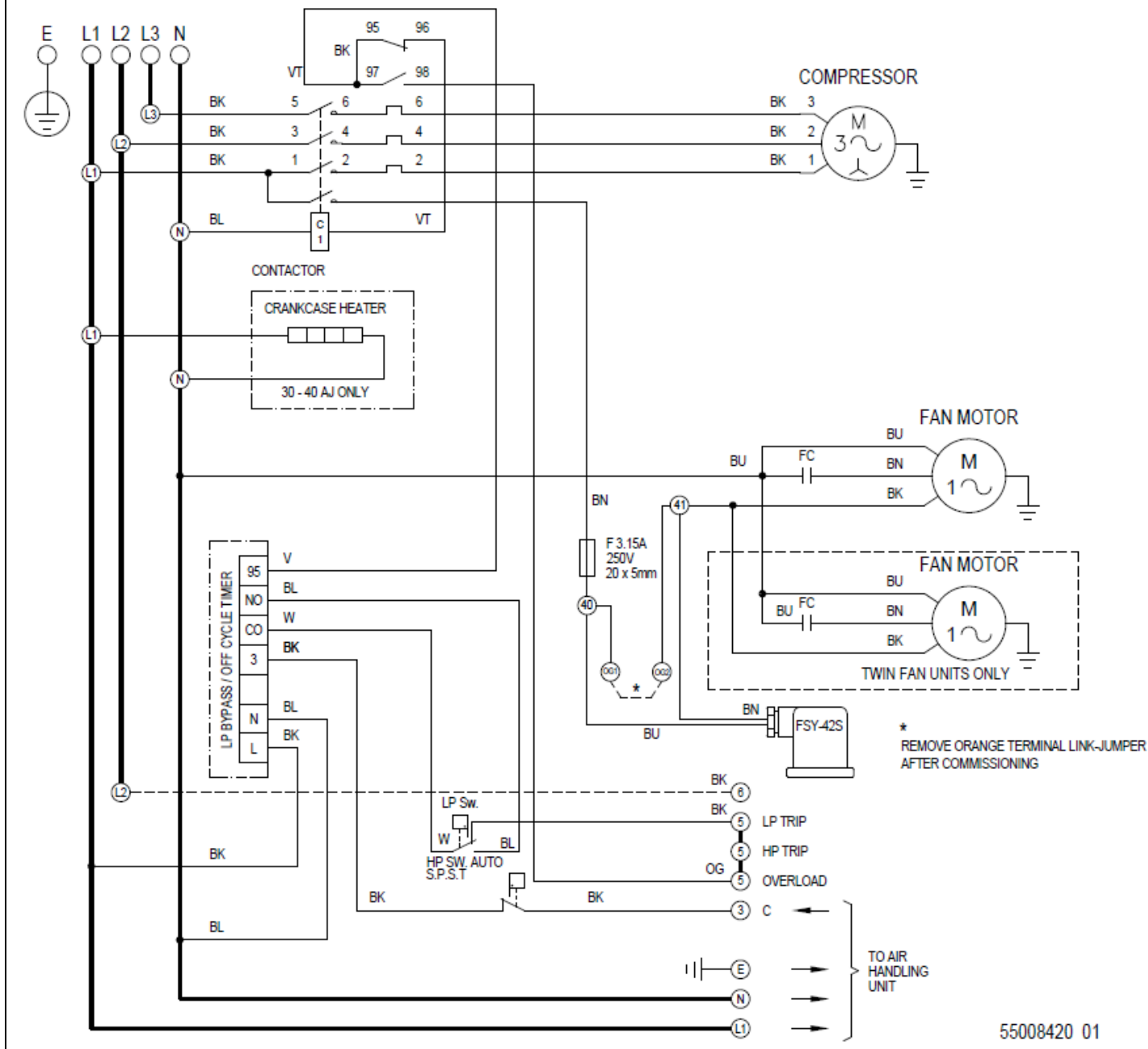

55008420 01

CKC 130 - 180 3PH

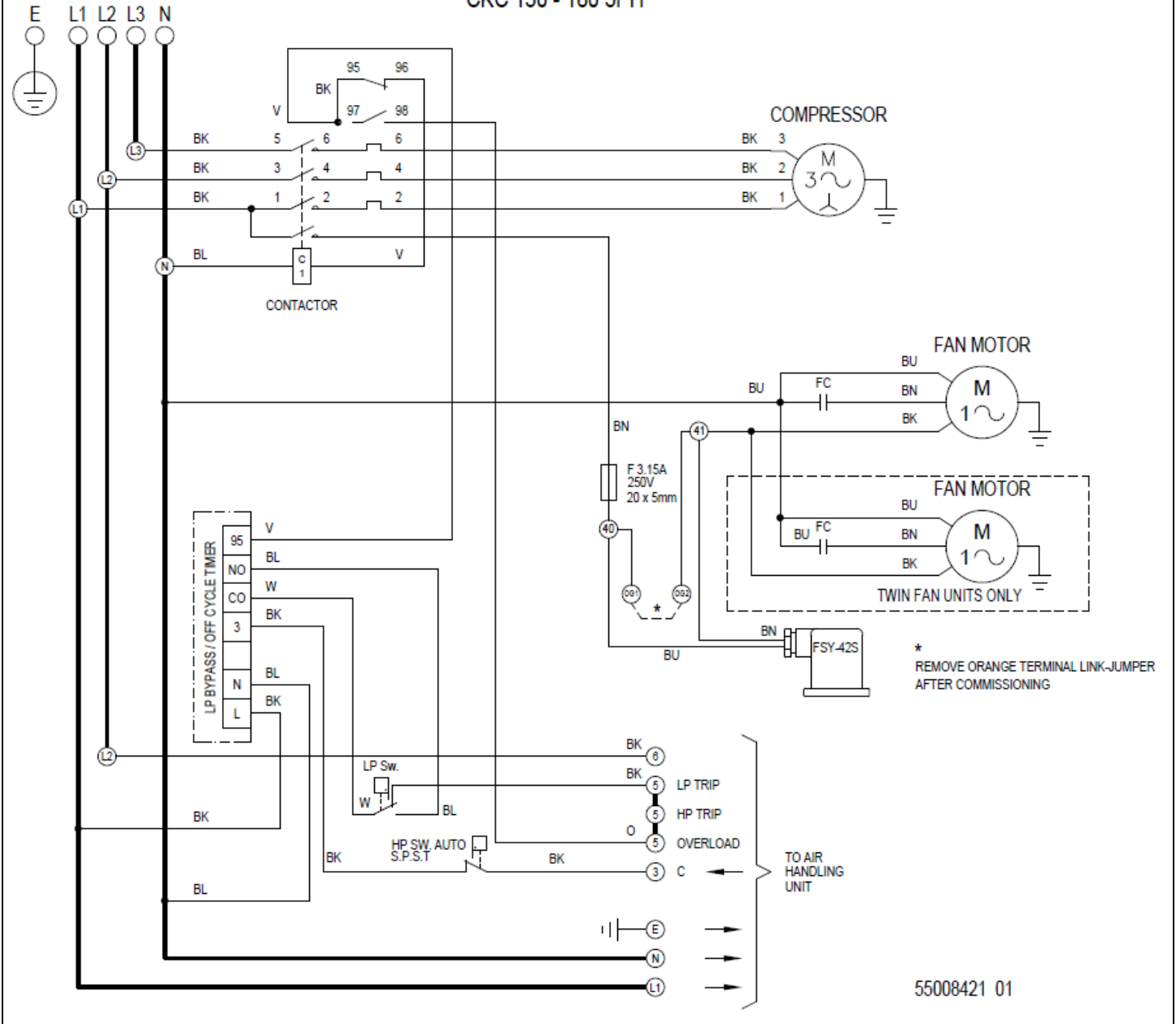

\* REMOVE ORANGE TERMINAL LINK-JUMPER AFTER COMMISSIONING

55008421 01

# CKC 200 3PH

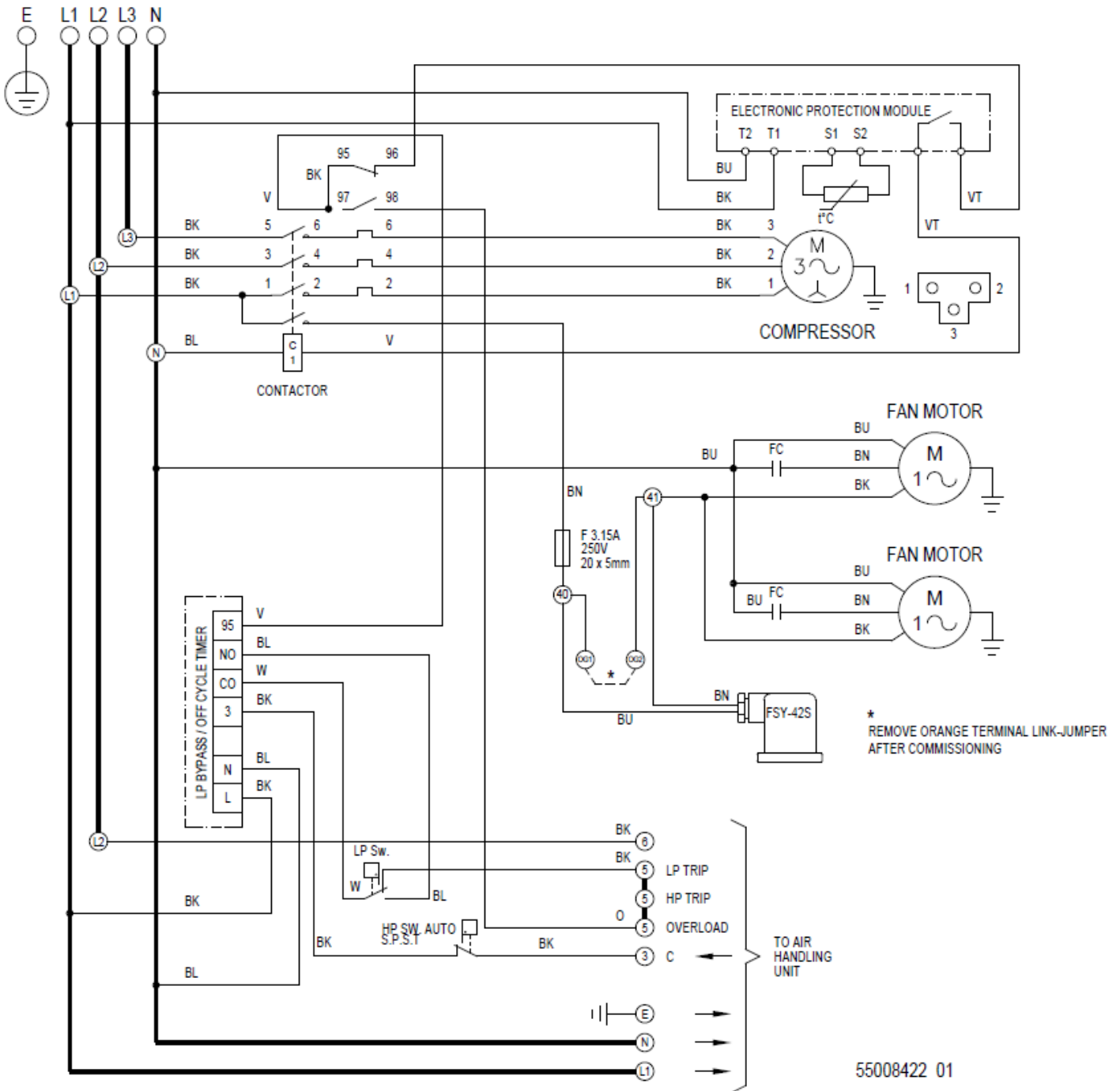

## R407C REFRIGERANT

### Charging the System:

1. Evacuate the system and interconnecting pipework ensuring the service valves are fully open.
2. Allow the evacuated system to draw in the majority of the refrigerant charge.
3. The final charge should be adjusted with the system running.
4. All units are fitted with head pressure control. The link wire across the orange terminals allows the fan to operate at full speed. **THIS SHOULD BE REMOVED AFTER CHARGING**
5. A random start delay of up to 1 minute occurs when mains is first applied. A 3 minute delay occurs between successive compressor operations on all systems.
6. Refrigerant and polyolester oil should be introduced through the Schrader valve in the service port on the suction service valve on the outdoor unit. **Ensure the refrigerant is the correct type, as shown on the rating plate.** R407C must always be added in the liquid state. **See indoor installation instruction for refrigerant charge weight.**
7. Run the system for a few minutes to allow it to stabilize. Where possible, charge to a sweat line on the evaporator. Typical suction pressures on short lines at UK conditions, with high speed evaporator fan, high speed condenser fan, should be; low temperature system approx 4.4 bar (65 psig).
8. **Systems should not be overcharged, to avoid liquid return to the compressor**
9. **HEAD PRESSURE CONTROL ALCO (FSY-42S)**  
The head pressure controller is factory set to suit the refrigerant. It may be necessary to adjust this to suit site conditions, to raise or lower the nominal head pressure.

#### ALCO (FSY-42S)

- a. With the system switched off, connect a high pressure gauge to the liquid line service valve.
- b. Switch on the system, and run for a few minutes to stabilise.
- c. The head pressure should be approximately:

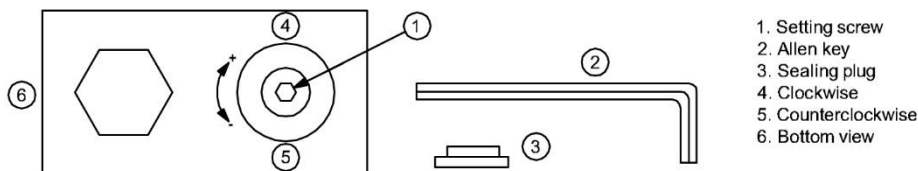

Min fan speed (0 rpm) and fan cut in pressure 200 psig (13.8 barg) are factory set and not adjustable.

**NOTE:** The condenser fan may stop if the operating pressure drops below 200 psig (13.8 barg)

**R407C: 270-280 psig (18.9-19.6barg)** to achieve this remove sealing plug and insert 2mm or 5/64" allen key into setting screw. Turn allen key clockwise (+) or counter clockwise (-) to readjust the setting. Do not turn setting screw **more than 3 turns clockwise (+3)**. Use following table as a quick guideline for setting:

#### Pressure changes per turn of adjusting screw:

Pressure change: 9.2 ... 21.2 bar:

Clockwise ~ +2,5 bar, counter clockwise ~ -2,5 bar

After adjustment, re-insert sealing plug and make sure that it is properly fitted. IP65 protection requires firmly sealed plug

#### NOTES:

Tolerances for condensing temperatures setpoint:  $\pm 2K$

## END OF LIFE REQUIREMENTS

Refrigerant must be recovered by a certificated technician before the plant is dismantled. Modern refrigerant recovery machines should be able to remove well over 95% of the refrigerant in an old system.

All recovered HFC refrigerants can either be:

- a) Sent for destruction by incineration at a licenced waste facility
- b) Sent to a specialist plant that can re-process the old refrigerant into a gas with properties identical to virgin refrigerant, to create "reclaimed refrigerant"
- c) Given a basic cleaning process, to create "recycled refrigerant"

Given the HFC supply shortage that will be created by the phase down process, it is worth trying to send the old refrigerant for reclamation as it may have a good residual value. If the old refrigerant is too contaminated it cannot be reclaimed and must be sent for destruction. It is important not to mix different gases in the same recovery cylinder – as this would render them unsuitable for reclamation.

Reclaimed refrigerant can be used in any refrigeration equipment. Recycled refrigerant must always be used with care as it may be contaminated or of unknown composition. The use of recycled refrigerant with a GWP above 2,500 is restricted to either (a) the organisation owning the plant from which the gas was recovered or (b) the organisation that carried out the recovery.

# COMPONENT IDENTIFICATION

CKC 15 - 100

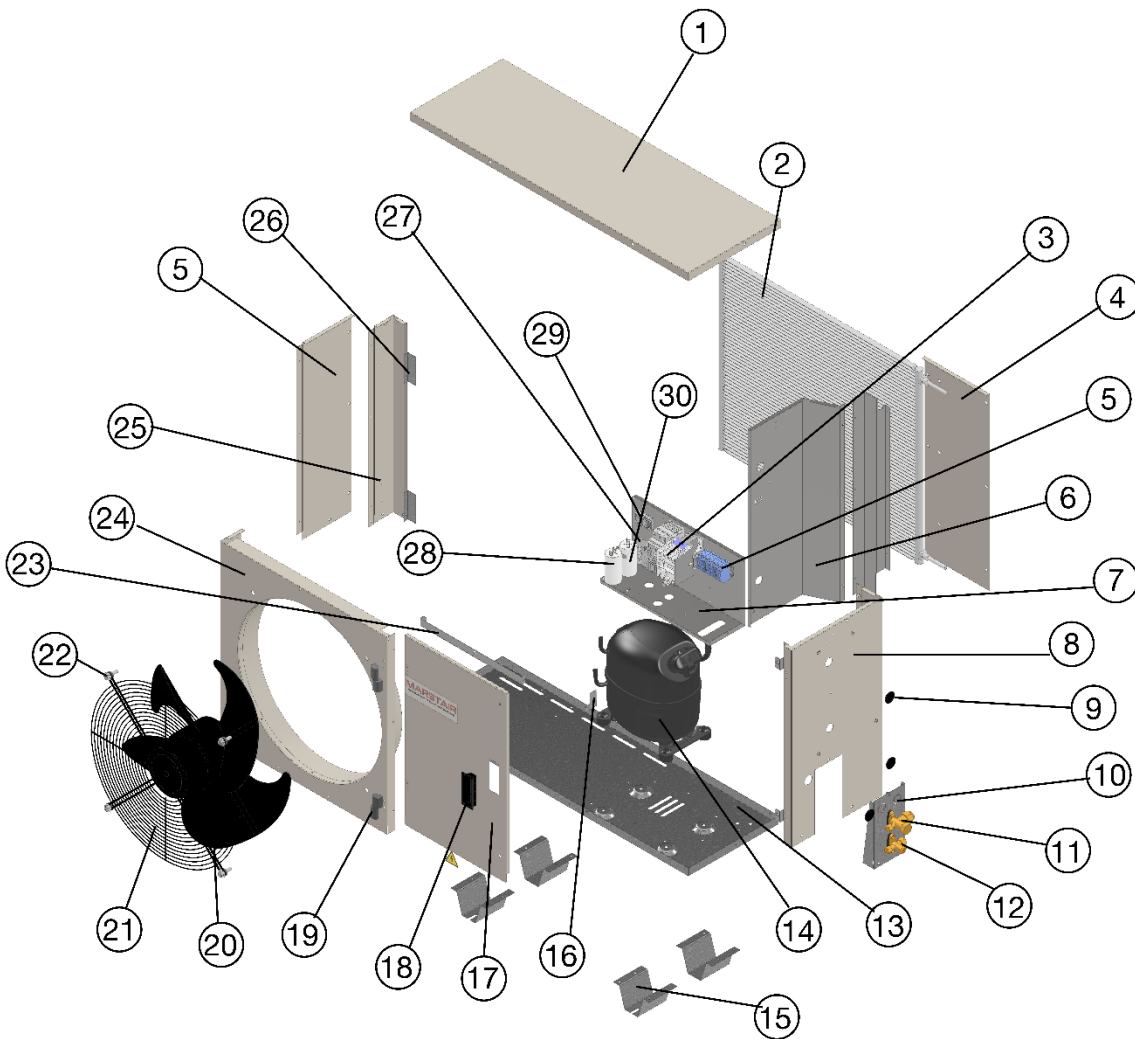

1	LID	12	SERVICE VALVE (LIQUID)	22	DAMPING WASHER
2	MICROCHANNEL COIL	13	BASE	23	DOOR BRACKET
3	CONTACTOR & OVERLOAD	14	COMPRESSOR	24	FASCIA PANEL
4	REAR ACCESS PANEL	15	MOUNTING FOOT	25	CORNER PANEL
5	TERMINALS	16	DOOR STOPPER	26	COIL BRACKET
6	BULKHEAD PANEL	17	HINGED DOOR	27	FAN SPEED CONTROLLER
7	ELECTRICS BOX	18	HANDLE	28	FAN CAPACITOR
8	SIDE PANEL	19	HINGE	29	TIMER
9	BLANKING PLUGS	20	FAN / MOTOR ASSEMBLY	30	COMPRESSOR CAPACITOR
10	VALVE PANEL	21	FAN GUARD		
11	SERVICE VALVE (SUCTION)				

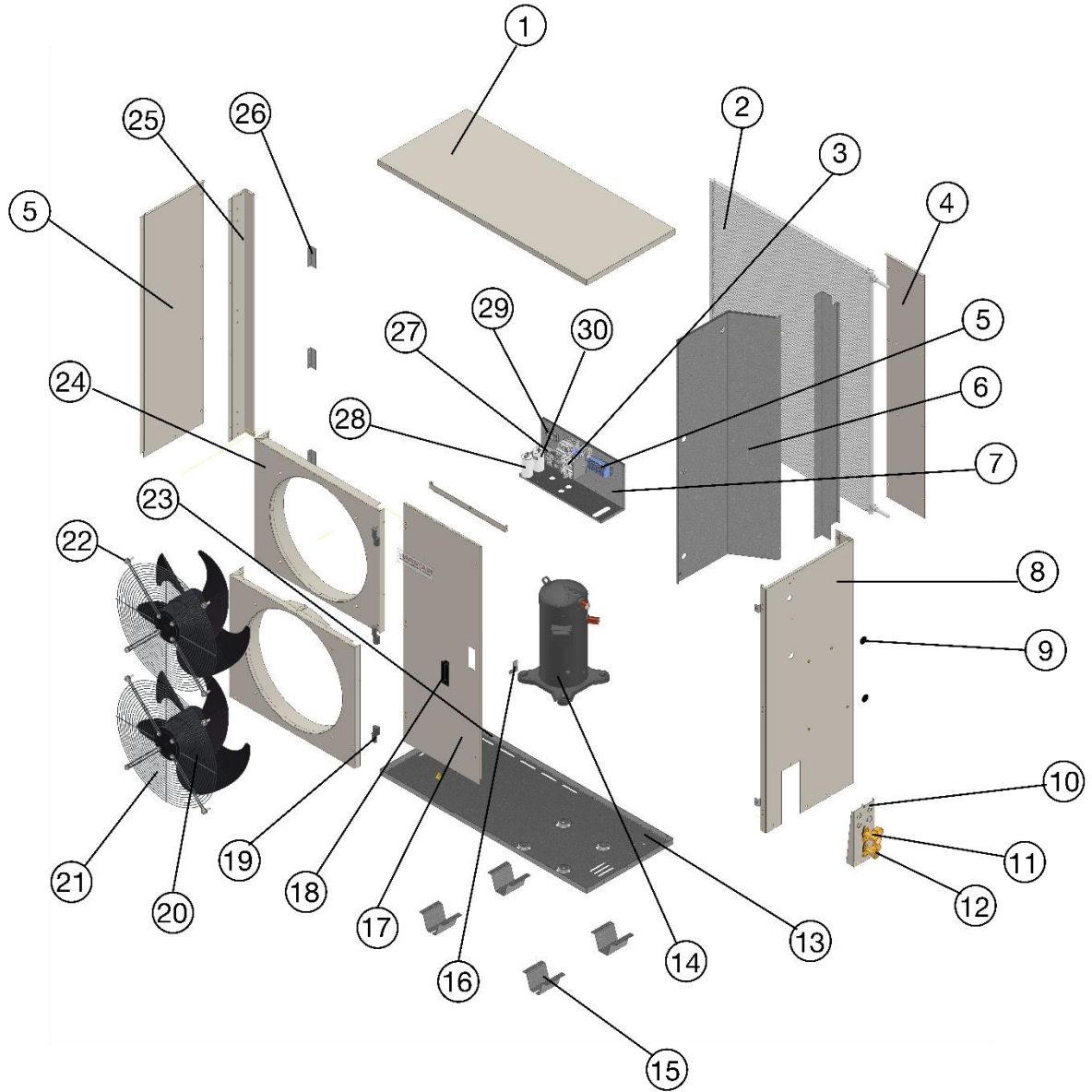

1	LID	12	SERVICE VALVE (LIQUID)	22	DAMPING WASHER
2	MICROCHANNEL COIL	13	BASE	23	DOOR BRACKET
3	CONTACTOR & OVERLOAD	14	COMPRESSOR	24	FASCIA PANEL
4	REAR ACCESS PANEL	15	MOUNTING FOOT	25	CORNER PANEL
5	TERMINALS	16	DOOR STOPPER	26	COIL BRACKET
6	BULKHEAD PANEL	17	HINGED DOOR	27	FAN SPEED CONTROLLER
7	ELECTRICS BOX	18	HANDLE	28	FAN CAPACITOR
8	SIDE PANEL	19	HINGE	29	TIMER
9	BLANKING PLUGS	20	FAN / MOTOR ASSEMBLY	30	COMPRESSOR CAPACITOR
10	VALVE PANEL	21	FAN GUARD		
11	SERVICE VALVE (SUCTION)				

## Commissioning Check List

The following information will be required to validate your 5yr parts warranty

Check and record	Value	Time Held For
Leak (tightness) test pressure	(bar)	(min)
Strength (pressure) test pressure	(bar)	(min)
Evacuation level	(microns)	(min)

	Value
Low pressure (gauge)	(barg)
Suction line temperature	(°C)
Evaporator superheat	(K)
Evaporator air ON / OFF	(°C)
High pressure (gauge)	(barg)
Liquid line temperature	(°C)
Condenser sub cooling	(K)
Condenser air ON / OFF	(°C)
Compressor current	(A)
Head pressure control set	(Y/N)
Refrigerant type	
Charged weight	(Kg)
Additional POE oil added	(g)
Pipe run length	(m)
Suction pipe size	(")
Liquid / Expansion pipe size	(")