



INDEX

<u>CONTENTS</u>	<u>PAGE</u>
GENERAL INFORMATION	3
PART NUMBERS	4-5
FEATURES & OPTIONS and KITS	6
DIMENSIONS & WEIGHTS	7
SPECIFICATION DETAILS	7-8
PERFORMANCE DATA	9
INSTALLATION	10-12
MOUNTING	12
DIMENSION DIAGRAMS	12-15
PIPEWORK	15
PIPE CONNECTIONS	16
REFRIGERANT	17
FANS	18
SERVICING	19
ELECTRICAL – WIRING DIAGRAM	20-21

GENERAL INFORMATION

NOTE

The instructions included in this document must be followed at all times to guarantee the correct installation, operation and maintenance of the system. The personnel in charge of installing, operating or servicing must take the instructions into account at all times. The guarantee will be void if these system instructions are not followed.

WARNING

MCUA units are specially designed for use in dangerous areas and comply with official regulations related to the risks of explosion. The equipment might not operate correctly if the operation instructions are not followed, the equipment is not correctly connected or is modified with no prior authorization, even in the case of minor modifications.

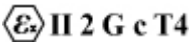
The MCUA units are marked  II 2 G c T4

Only qualified personnel who understand the regulations related to the risk of explosion can handle this type of system.

Matched MMC units and evaporators are to be installed in safe areas.

All of Marstair's equipment, including the complete line of accessories, have been manufactured with the most rigorous manufacturing processes, quality systems and quality assurance procedures.

The equipment, testing, manufacturing and control activities comply with CEE regulations, in particular, with current safety regulations. In addition, the materials and standardised components used to manufacture the equipment comply with the relevant standards and are covered by the corresponding quality certificates.

The design and manufacturing processes of the different Marstair equipment have taken into account the appropriate regulations and Risk Elimination instructions, in order to comply with the Essential Safety and Health Requirements.

Whenever allowed by the configuration and manufacturing process, Marstair incorporates the most appropriate Safety devices directly. If this is not possible at the factory, due to specific assembly or application conditions, all additional Safety accessories are available and can be installed before starting the equipment.

These accessories will cover the concept of residual risks described in the regulations.

TEV Limited recommends the installation of MAINTENANCE SWITCHES as a high safety accessory (appropriate for use in potentially explosive environments, in accordance with Directive ATEX 94/4/CE), with manual disconnection, allowing safe maintenance activities.

1. Marstair Ltd recommend that personnel working on this equipment be skilled and fully conversant with the appropriate Air Conditioning, Refrigeration and Electrical practices and have sound knowledge of current Industrial Safe Working practices.
2. These units are supplied with a dry nitrogen charge and polyolester oil.
Do not open the valves until the system is fully installed.
Do not mix oils or refrigerants.
3. These units contain live electrical components, moving parts and refrigerant under pressure. Always site out of reach of children and protect from vandalism.
4. The data plates only give information for individual units. For system details add input power and current of all units, including any heater load.
5. FUSES- for recommended fuse size see indoor unit instructions.

PART NUMBERS

MCUA

Part Number	Description	Case material	Frequency - Hz	Heat Exchanger Material
55051007	MCUA 15-30 3/60/460 SS	Stainless Steel 316	60	Copper Aluminium
55051008	MCUA 40 3/60/460 SS	Stainless Steel 316	60	Copper Aluminium
55051009	MCUA 50-80 3/60/460 SS	Stainless Steel 316	60	Copper Aluminium
55051010	MCUA 90-100 3/60/460 SS	Stainless Steel 316	60	Copper Aluminium
55051011	MCUA 130-165 3/60/460 SS	Stainless Steel 316	60	Copper Aluminium
55051012	MCUA 180-200 3/60/460 SS	Stainless Steel 316	60	Copper Aluminium
55051013	MCUA15-30 3/60/460 SS PROCOIL	Stainless Steel 316	60	Copper Aluminium Coated
55051014	MCUA40 3/60/460 SS PROCOIL	Stainless Steel 316	60	Copper Aluminium Coated
55051015	MCUA50-80 3/60/460 SS PROCOIL	Stainless Steel 316	60	Copper Aluminium Coated
55051016	MCUA90-100 3/60/460 SS PROCOIL	Stainless Steel 316	60	Copper Aluminium Coated
55051017	MCUA130-165 3/60/460 SS PROCOIL	Stainless Steel 316	60	Copper Aluminium Coated
55051018	MCUA180-200 3/60/460 SS PROCOIL	Stainless Steel 316	60	Copper Aluminium Coated
55051019	MCUA15-30 3/60/460 SS COP/COP	Stainless Steel 316	60	Copper/Copper
55051020	MCUA40 3/60/460 SS COP/COP	Stainless Steel 316	60	Copper/Copper
55051021	MCUA50-80 3/60/460 SS COP/COP	Stainless Steel 316	60	Copper/Copper
55051022	MCUA90-100 3/60/460 SS COP/COP	Stainless Steel 316	60	Copper/Copper
55051023	MCUA130-165 3/60/460 SS COP/COP	Stainless Steel 316	60	Copper/Copper
55051024	MCUA180-200 3/60/460 SS COP/COP	Stainless Steel 316	60	Copper/Copper
55051043	MCUA 15-30 3/50/460 SS	Stainless Steel 316	50	Copper Aluminium
55051044	MCUA 40 3/50/460 SS	Stainless Steel 316	50	Copper Aluminium
55051045	MCUA 50-80 3/50/460 SS	Stainless Steel 316	50	Copper Aluminium
55051046	MCUA 90-100 3/50/460 SS	Stainless Steel 316	50	Copper Aluminium
55051047	MCUA 130-165 3/50/460 SS	Stainless Steel 316	50	Copper Aluminium
55051048	MCUA 180-200 3/50/460 SS	Stainless Steel 316	50	Copper Aluminium
55051049	MCUA15-30 3/50/460 SS PROCOIL	Stainless Steel 316	50	Copper Aluminium Coated
55051050	MCUA40 3/50/460 SS PROCOIL	Stainless Steel 316	50	Copper Aluminium Coated
55051051	MCUA50-80 3/50/460 SS PROCOIL	Stainless Steel 316	50	Copper Aluminium Coated
55051052	MCUA90-100 3/50/460 SS PROCOIL	Stainless Steel 316	50	Copper Aluminium Coated
55051053	MCUA130-165 3/50/460 SS PROCOIL	Stainless Steel 316	50	Copper Aluminium Coated
55051054	MCUA180-200 3/50/460 SS PROCOIL	Stainless Steel 316	50	Copper Aluminium Coated
55051055	MCUA15-30 3/50/460 SS COP/COP	Stainless Steel 316	50	Copper/Copper
55051056	MCUA40 3/50/460 SS COP/COP	Stainless Steel 316	50	Copper/Copper
55051057	MCUA50-80 3/50/460 SS COP/COP	Stainless Steel 316	50	Copper/Copper
55051058	MCUA90-100 3/50/460 SS COP/COP	Stainless Steel 316	50	Copper/Copper
55051059	MCUA130-165 3/50/460 SS COP/COP	Stainless Steel 316	50	Copper/Copper
55051060	MCUA180-200 3/50/460 SS COP/COP	Stainless Steel 316	50	Copper/Copper

MMC

Part Number	Description	Frequency - Hz	With Neutral Star	No Neutral Delta
55052001	MMC30 3/50/400	50	Star	
55052002	MMC40 3/50/400	50	Star	
55052003	MMC50 3/50/400	50	Star	
55052004	MMC60 3/50/400	50	Star	
55052005	MMC80 3/50/400	50	Star	
55052006	MMC90 3/50/400	50	Star	
55052007	MMC100 3/50/400	50	Star	
55052008	MMC130 3/50/400	50	Star	
55052009	MMC150 3/50/400	50	Star	
55052010	MMC165 3/50/400	50	Star	
55052011	MMC180 3/50/400	50	Star	
55052012	MMC200 3/50/400	50	Star	
55052013	MMC40 3/60/460	60	Star	
55052014	MMC50 3/60/460	60	Star	
55052015	MMC60 3/60/460	60	Star	
55052016	MMC80 3/60/460	60	Star	
55052017	MMC90 3/60/460	60	Star	
55052018	MMC100 3/60/460	60	Star	
55052019	MMC130 3/60/460	60	Star	
55052020	MMC150 3/60/460	60	Star	
55052021	MMC165 3/60/460	60	Star	
55052022	MMC180 3/60/460	60	Star	
55052023	MMC200 3/60/460	60	Star	
55052024	MMC30 3/50/460 DELTA	50		Delta
55052025	MMC40 3/50/460 DELTA	50		Delta
55052026	MMC50 3/50/460 DELTA	50		Delta
55052027	MMC60 3/50/460 DELTA	50		Delta
55052028	MMC80 3/50/460 DELTA	50		Delta
55052029	MMC90 3/50/460 DELTA	50		Delta
55052030	MMC100 3/50/460 DELTA	50		Delta
55052031	MMC130 3/50/460 DELTA	50		Delta
55052032	MMC150 3/50/460 DELTA	50		Delta
55052033	MMC165 3/50/460 DELTA	50		Delta
55052034	MMC180 3/50/460 DELTA	50		Delta
55052035	MMC200 3/50/460 DELTA	50		Delta
55052036	MMC40 3/60/460 DELTA	60		Delta
55052037	MMC50 3/60/460 DELTA	60		Delta
55052038	MMC60 3/60/460 DELTA	60		Delta
55052039	MMC80 3/60/460 DELTA	60		Delta
55052040	MMC90 3/60/460 DELTA	60		Delta
55052041	MMC100 3/60/460 DELTA	60		Delta
55052042	MMC130 3/60/460 DELTA	60		Delta
55052043	MMC150 3/60/460 DELTA	60		Delta
55052044	MMC165 3/60/460 DELTA	60		Delta
55052045	MMC180 3/60/460 DELTA	60		Delta
55052046	MMC200 3/60/460 DELTA	60		Delta

FEATURES AND OPTIONS

DESCRIPTION	MMC	MCUA
Easy access for installation and service	✓	✓
Suction and liquid services valves	✓	✓
Capacitor start relay 1ph (MMC 30-40)	•	n/a
PTC resistor 1ph	•	n/a
Hot gas bypass valve	✓	n/a
LP cut-out auto	✓	n/a
HP cut-out auto	✓	n/a
Isolator	•	n/a
3 minute start time delay	✓	n/a
Wall mount brackets	•	n/a
Contactora	✓	n/a
Over load (standard on 3ph)	✓	n/a
Low ambient start	✓	n/a
✓ = Standard • = Option n/a = Not applicable		

KITS

MMC		
DESCRIPTION	MODEL	PART NUMBER
Pressure switch (HP manual)	All	55000398
Volt free relay	All	55000395
Wall mount brackets	30-80	55021100
	90-200	55021101
Overload (standard on 3ph)	30	55000410
	40-60	55000446
	80-90	55000449
	30-40	55000412
PTC (hard start 1ph)	40	55000414
CSR (hard start 1ph)	30	55000415
	1ph 30-60	55000419
Isolator for remote mounting	1ph 80-90	55000418
	3ph All	55000419
	Reciprocating 30-40	55000454
Compressor jacket	Scroll 50-80	55000455
	Scroll 90-180	55000456
	Scroll 200	55000457

DIMENSIONS AND WEIGHTS

UNPACKED

MCUA

Model	30	40	50-80	90-100	130-165	180-200
Height mm	620	620	720	820	1080	1275
Width mm	900	900	1000	1000	1000	1100
Depth mm	511	511	511	561	636	636
Weight kg	22	25	33	37	58	68

MMC

Model	30	40	50	60	80	90	100	130	150	165	180	200
Height mm	700	700	700	700	700	700	700	700	700	700	700	700
Width mm	480	480	480	480	480	480	480	480	480	480	480	480
Depth mm	475	475	475	475	475	475	475	475	475	475	475	475
Weight kg	41	43	43	44	45	51	53	56	59	64	65	85

SPECIFICATION DETAILS

MMC & MCUA		30	40	50	60	80	90	100	130	150	165	180	200
Nominal cooling capacity	kW	3.7	4.2	5.8	7.0	7.4	8.2	10.9	12.4	13.9	14.7	17.1	19.9

3Ph (400v 50Hz) MMC

Power (nominal)	kW	-	-	1.6	2.0	1.9	2.4	3.0	4.1	4.3	4.4	5.3	6.0	7.0	9.4
Starting current LRA	A	-	-	18	22	26	32	40	48	51	62	68	71	71	98
Nominal current FLA	A	-	-	3.6	4.8	4.2	4.2	4.9	7.1	7.2	7.7	8.7	9.5	11.9	16.9

Condenser Fan

Model	MCUA					
	30	40	50-80	90-100	130-165	180-200
Airflow (m ³ /s)	0.97	0.97	0.97	0.97	1.85	1.85
Max Current @ 400V (A)	1.05	1.05	1.05	1.05	2.1	2.1
Fans :no x diameter (mm)	1 x 400	1 x 400	1 x 400	1 x 400	2 x 400	2 x 400
Fan max speed (RPM)	1400	1400	1400	1400	1400	1400

Condenser fan sound power

Frequency	125	250	500	1000	2000	4000
dB(A)	45	57	65	70	70	66

MMC Sound power levels

MMC	Frequency Hz						dBA
	125	250	500	1K	2K	4K	
30	66	61	65	59	53	48	65
40	66	61	65	58	53	48	65
50	67	64	66	64	59	52	68
60	67	64	67	67	61	52	70
80	69	67	67	62	56	52	68
90	79	65	65	62	59	54	68
100	75	69	71	64	60	54	70
130	65	67	68	66	63	53	70
165	66	67	67	65	64	54	73
180	66	36	67	61	65	55	73
200	67	66	68	67	66	57	76

PERFORMANCE DATA

MMC & MCUA CAPACITIES

MODEL	AIR ON TO CONDENSER °C	SATURATED SUCTION TEMPERATURE °C											
		-2.5		0		2.5		5		7.5		10	
		COOLING CAPACITY AND POWER INPUT KW											
		CAP.	POWER	CAP.	POWER	CAP.	POWER	CAP.	POWER	CAP.	POWER	CAP.	POWER
MMC & MCUA 30	25	2.87	1.02	3.22	1.05	3.53	1.06	3.74	1.04	4.12	1.07	4.49	1.10
	30	2.71	1.10	3.06	1.13	3.27	1.12	3.51	1.12	3.84	1.15	4.19	1.18
	35	2.59	1.20	2.82	1.20	3.03	1.19	3.36	1.23	3.68	1.26	3.79	1.22
	40	2.38	1.27	2.17	1.32	2.80	1.26	3.12	1.31	3.32	1.31	3.62	1.35
	45	2.11	1.30	2.43	1.36	2.53	1.31	2.84	1.37				
MMC & MCUA 40	25	3.38	1.13	3.70	1.15	4.02	1.16	4.35	1.18	4.67	1.19	5.00	1.21
	30	3.19	1.22	3.50	1.24	3.81	1.26	4.11	1.28	4.42	1.30	4.73	1.32
	35	3.01	1.31	3.30	1.33	3.59	1.36	3.88	1.38	4.17	1.41	4.46	1.43
	40	2.84	1.40	3.11	1.43	3.37	1.47	3.63	1.50	3.89	1.53	4.15	1.56
	45	2.68	1.51	2.91	1.55	3.15	1.58	3.38	1.62	3.61	1.66	3.85	1.70
MMC & MCUA 50	25	4.57	1.87	5.09	2.03	5.51	2.14	5.97	2.25	6.41	2.38	6.79	2.51
	30	4.34	1.95	4.75	2.09	5.25	2.19	5.63	2.32	6.04	2.45	6.49	2.58
	35	3.94	2.00	4.42	2.13	4.91	2.24	5.29	2.36	5.75	2.49	6.09	2.65
	40	3.76	2.05	4.22	2.18	4.58	2.29	5.04	2.41	5.39	2.58	5.69	2.74
	45	3.50	2.12	3.93	2.22	4.37	2.35	4.69	2.48				
MMC & MCUA 60	25	5.43	2.22	6.02	2.27	6.61	2.31	7.21	2.37	7.80	2.42	8.39	2.47
	30	5.06	2.46	5.64	2.51	6.22	2.56	6.80	2.62	7.39	2.67	7.97	2.73
	35	4.77	2.72	5.33	2.78	5.89	2.83	6.45	2.89	7.01	2.95	7.57	3.01
	40	4.39	3.01	4.91	3.07	5.43	3.13	5.95	3.19	6.47	3.26	6.99	3.32
	45	4.02	3.32	4.49	3.40	4.97	3.46	5.45	3.53	5.93	3.60		
MMC & MCUA 80	25	6.07	2.26	6.64	2.31	7.21	2.37	7.79	2.42	8.36	2.47	8.93	2.53
	30	5.68	2.49	6.23	2.54	6.77	2.60	7.32	2.66	7.87	2.71	8.42	2.77
	35	5.28	2.72	5.81	2.78	6.33	2.83	6.86	2.89	7.38	2.95	7.91	3.01
	40	4.90	3.03	5.39	3.10	5.88	3.16	6.37	3.23	6.86	3.29	7.35	3.36
	45	4.52	3.35	4.97	3.42	5.43	3.49	5.88	3.56	6.33	3.63		
MMC & MCUA 90	25	7.16	2.89	7.71	2.95	8.26	3.01	8.81	3.06	9.36	3.12	9.91	3.18
	30	6.69	3.17	7.21	3.24	7.74	3.30	8.27	3.36	8.79	3.42	9.32	3.48
	35	6.22	3.46	6.72	3.52	7.22	3.59	7.72	3.65	8.23	3.72	8.73	3.78
	40	5.80	3.79	6.27	3.86	6.74	3.93	7.22	4.00	7.69	4.07	8.17	4.14
	45	5.38	4.12	5.82	4.20	6.27	4.27	6.71	4.34	7.16	4.42	7.60	4.49
MMC & MCUA 100	25	7.87	3.18	9.10	3.42	10.40	3.66	11.52	3.87	12.61	3.87	13.83	3.86
	30	7.60	3.23	8.73	3.88	9.68	3.81	10.71	4.05	11.66	4.18	12.71	4.29
	35	7.00	3.24	8.06	3.56	9.03	3.87	9.92	4.13	10.91	4.31	11.89	4.52
	40	6.17	3.16	7.12	3.54	8.14	3.86	8.91	4.17	9.86	4.47	10.80	4.75
	45	5.12	2.95	6.18	3.47	7.07	3.89	7.89	4.25				
MMC & MCUA 130	25	9.69	3.14	10.71	3.46	11.72	3.73	12.76	4.01	13.71	4.28	14.56	4.54
	30	9.09	3.16	10.07	3.46	11.11	3.74	12.12	4.08	13.05	4.36	13.93	4.68
	35	8.27	3.27	9.32	3.61	10.27	3.91	11.34	4.25	12.41	4.56	13.29	4.91
	40	7.61	3.29	8.58	3.65	9.54	4.01	10.44	4.31	11.46	4.68		
	45	6.89	3.34	7.63	3.68	8.68	4.09						
MMC & MCUA 150	25	11.06	3.73	12.26	4.13	13.26	4.46	14.30	4.82	15.24	5.15	16.19	5.47
	30	10.42	3.75	11.52	4.14	12.56	4.48	13.57	4.88	14.56	5.24	15.48	5.63
	35	9.46	3.89	10.59	4.32	11.61	4.68	12.69	5.08	13.77	5.47	14.77	5.90
	40	8.70	3.90	9.79	4.35	10.76	4.78	11.67	5.15				
	45	7.90	3.98	8.89	4.40								
MMC & MCUA 165	25	11.97	4.13	13.30	4.57	14.29	4.95	15.32	5.36	16.26	5.73	17.28	6.09
	30	11.31	4.15	12.49	4.59	13.52	4.98	14.54	5.42	15.57	5.82	16.51	6.26
	35	10.26	4.30	11.44	4.79	12.51	5.19	13.59	5.64	14.67	6.08	15.75	6.56
	40	9.43	4.31	10.60	4.81	11.58	5.29	12.49	5.17				
	45	8.57	4.41										
MMC & MCUA 180	25	13.42	4.71	14.97	5.12	16.28	5.45	17.63	5.79	18.86	6.13	20.27	6.47
	30	12.74	4.75	14.13	5.16	15.39	5.51	16.76	5.90	18.08	6.26	19.34	6.64
	35	11.52	4.94	12.94	5.38	14.34	5.76	15.67	6.16	17.12	6.56	18.51	6.98
	40	10.63	4.96	11.97	5.44	13.28	5.89	14.43	6.26	15.95	6.74	17.31	7.18
	45	9.72	5.10	10.95	5.61	12.17	6.09	13.31	6.49	14.63	6.98		
MMC & MCUA 200	25	15.28	5.37	16.96	5.90	18.96	6.47	21.12	6.87	22.34	7.28	23.48	7.65
	30	14.42	5.41	16.01	5.92	17.73	6.41	19.75	6.96	21.18	7.40	22.52	7.88
	35	13.13	5.51	14.68	6.17	16.49	6.68	18.30	7.23	19.88	7.74	21.48	8.27
	40	12.03	5.62	13.59	6.24	15.13	6.82	16.58	7.31	18.33	7.92		
	45	10.99	5.78	12.36	6.42	13.80	7.03						

NOTE: OPERATION IN THE SHADED AREAS OF THE TABLE WILL RESULT IN UNACCEPTABLY HIGH CONDENSING TEMPERATURE AND SHOULD BE AVOIDED.

INSTALLATION

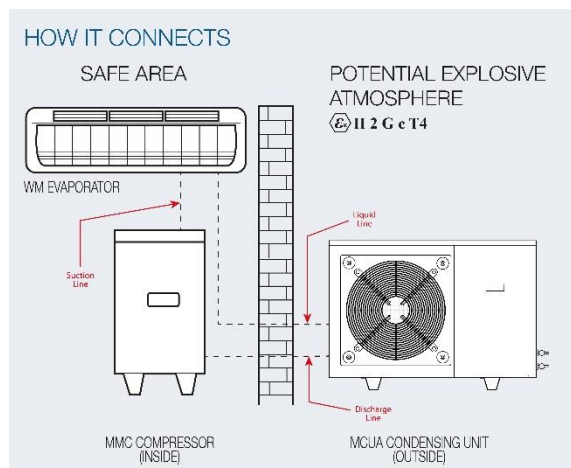

1. Commissioning

1.1 Reception verification

The packaging must not show any signs of incorrect handling at reception. Perform a visual inspection of the equipment to make sure that it has not been damaged during transport and that the damage does not affect the correct operation. If external damage is observed, report it to the carrier and the Commercial Department of TEV Limited.

Turn the propeller or the fan. There should be no unwanted stress or tension.

Check the model to ensure its characteristics correspond to those included in the delivery note.

Check all information in the plate of characteristics of the equipment, including category and type of protection, as well as ensuring the motor plate marks comply with those of the electrical installation, voltage, frequency, etc.

All equipment manufactured by TEV Limited are verified and tested after being assembled. (Check all accessories to ensure they are in good condition, if applicable).

2. Handling

2.1 Transport

The equipment is supplied on a palette or in a crate, to avoid damaging the equipment.

2.2 Conservation and storage

The equipment must be stored inside a warehouse, in dry environments with no vibrations or dust.

2.3 Lifting

The units should be lifted by using fork lifts the unit. Special attention should be paid to avoid the unit tilting on the fork lift.

2.4 Installation

All certification-related values described in the plates of characteristics must be carefully checked, in order to ensure the protection of the equipment, environment and area are compatible with the equipment.

2.5 Fan / Motor assemblies are packed separately to prevent transit damage so must be fitted during installation.

Standards EN 1127-1 (Prevention and protection against explosions) and EN 13463-1 (Non-electrical equipment used in potentially explosive environments) must be observed.

NOTE

The instruction manual of the fan manufacturer is included in each unit. The following indications must be observed:

- Ground connection.
- Connection of the power supply cable and terminals, in compliance with EN 60204-1.
- Use of certified stuffing boxes for increased safety and fireproof motors, with the adequate IP protection.

The units manufactured by Marstair have been specially designed to allow easy assembly on walls and floors.

Ensure the fan heat exchanger is not deformed mechanically during installation.

The location, arrangement and dimensions of fixing drills are standardised and are designed to offer the level of safety and stability required.

The unit must be firmly fixed to the support structure with screws and washers, using the drills in the envelope frame (helicoidal) or support or suction inlets and discharge outlets (centrifugal).

Fixing bolts which have not been properly tightened will produce harmful noises and vibrations.

WARNING

Ensure there are no unwanted particles in the frame and conduits before starting the fan, including any loose elements that could be dragged by the flow of air and cause damage.

The following points must be taken into account for the correct assembly of the equipment:

- a. Follow the general safety instructions during installation.
- b. Observe the correct location measures with no interference.
- c. Distance between fixing holes must match that of the unit.
- d. The screws used will have the correct dimensions, quality and resistance required to support the load of the unit.
- e. Use the appropriate tools and follow the correct assembly instructions to avoid overcharging the unit.

WARNING

Rotating parts of the fan (mainly propellers and turbines) are VERY DANGEROUS elements.

The propeller or turbine must rotate freely with no added tension after the mechanical assembly. The unit can only operate at the voltage described in the motor's plate of characteristics.

All electrical characteristics included on the plate must comply with the power supply network characteristics, voltage (V) and frequency (Hz).

The equipment can be connected after the first test has been carried out, in compliance with the instructions of the low voltage regulations.

- a. The correct cable section (mm²) with the corresponding motor power and consumption (A) will be used.
- b. Disassemble the top cover of the motor terminal box and prepare the arrangement of the said terminals, as required for a correct connection. Layouts and diagrams must be observed at all times when connecting the terminals.
- c. The motor terminal box will always include a diagram of connections.
- d. The motor's power supply will be disconnected during these operations. After connecting the motor with the power supply disconnected, the terminals will be checked to verify they are correctly tightened, with the adequate grounding connection (earth).
- e. The power supply cable must not have any sort of interferences or be in contact with the rotating parts of the fan or mobile connections.
- f. Connect the MCUA to the power supply and start it, verify the correct rotation direction and check the level of consumption (intensity A), which should be correct and equivalent to the nominal intensity of the motor. See instructions to change the rotation direction.

WARNING

Disconnect the MCUA before checking or handling the equipment and wait until the propeller or turbine has stopped.

The risk of an explosive environment at work should be avoided at all times.

NOTE

The following must be verified after the first hour of operation:

- Motor consumption (A),
- fixing and tightening of fixing screws

3. Safety issues

MCUA units are manufactured to work under potentially explosive environments require special attention.

Said units must be installed and used by qualified personnel who understand the national safety regulations and legislation.

The safety equipment required to prevent accidents during installation and operation must be used, in accordance with local regulations.

Important Information

- 3.1 Do not rest or climb on the unit
- 3.2 Ensure that the unit is adequately grounded

MOUNTING MMC & MCUA

Whether floor or wall mounted, it is essential that the mounting surface is capable of supporting the unit weight. Leave space around the unit for air circulation and access for installation and maintenance.

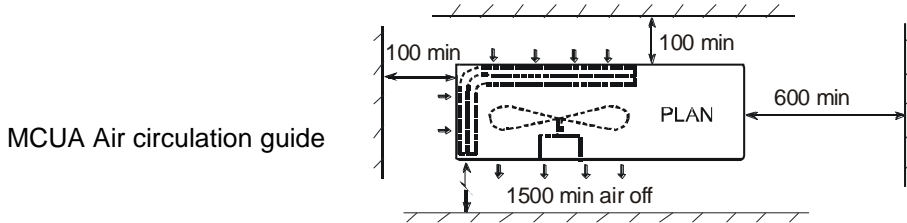

Dimensions in mm.

MMC Units must be installed in a safe area.

DIMENSIONS

MCUA 15-40

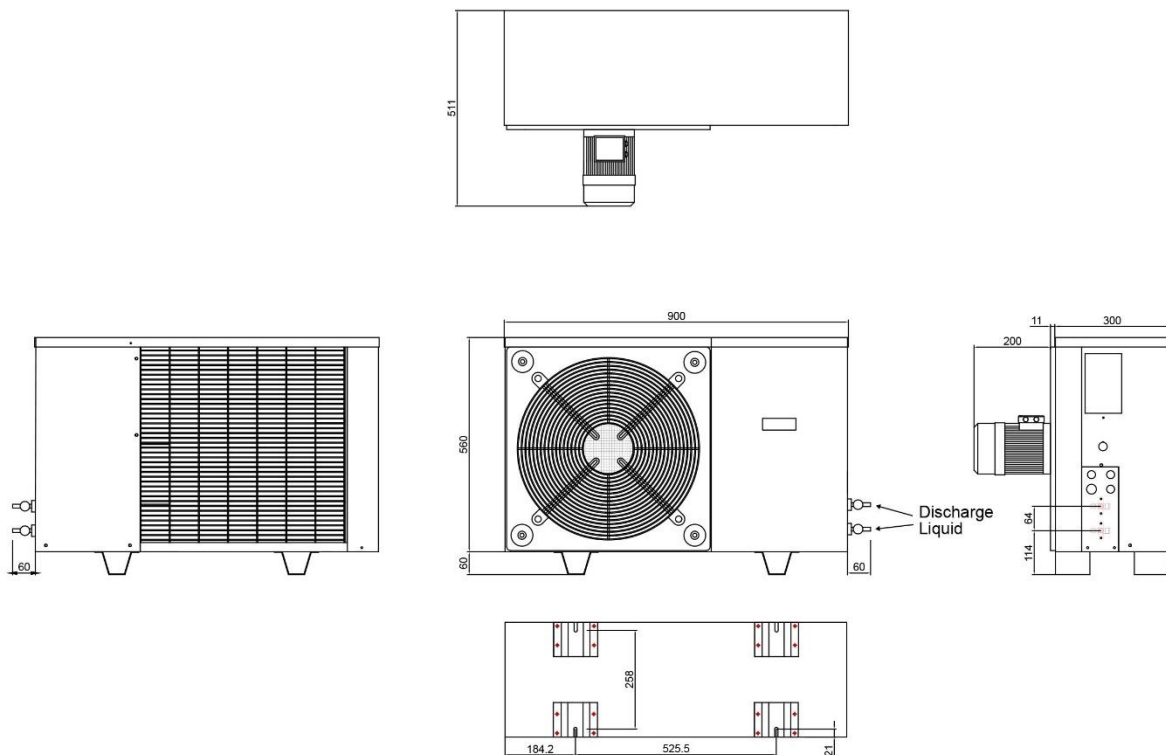

MCUA 50-80

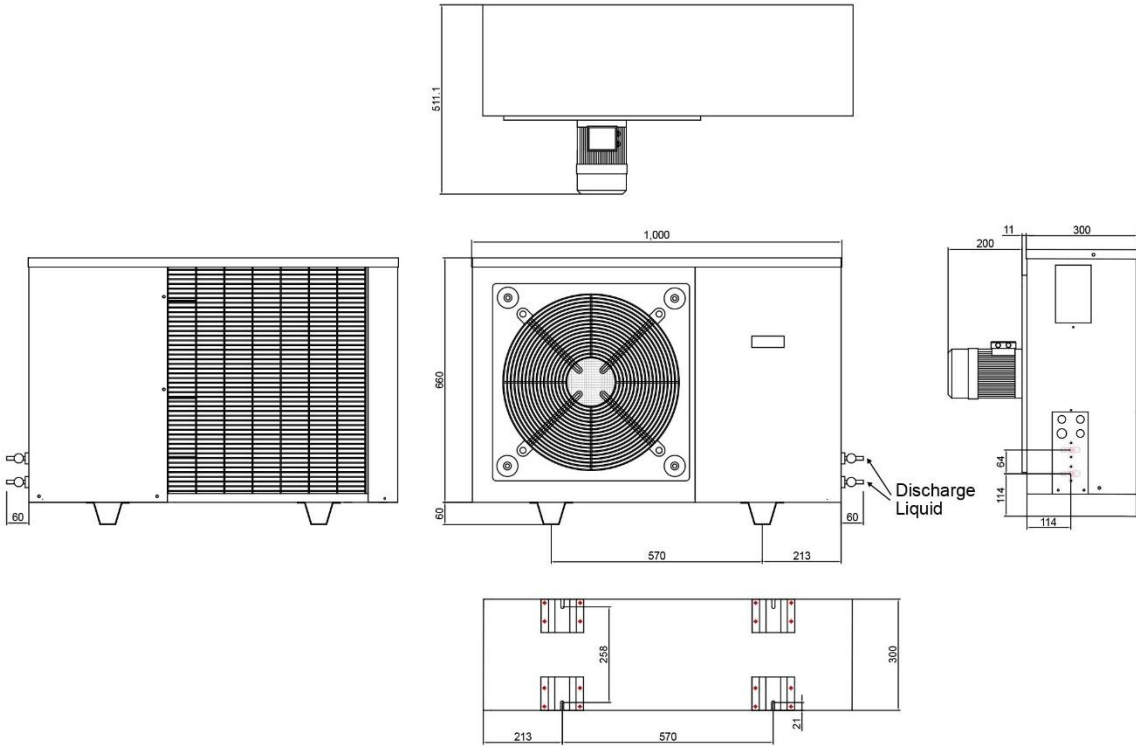

MCUA 90-100

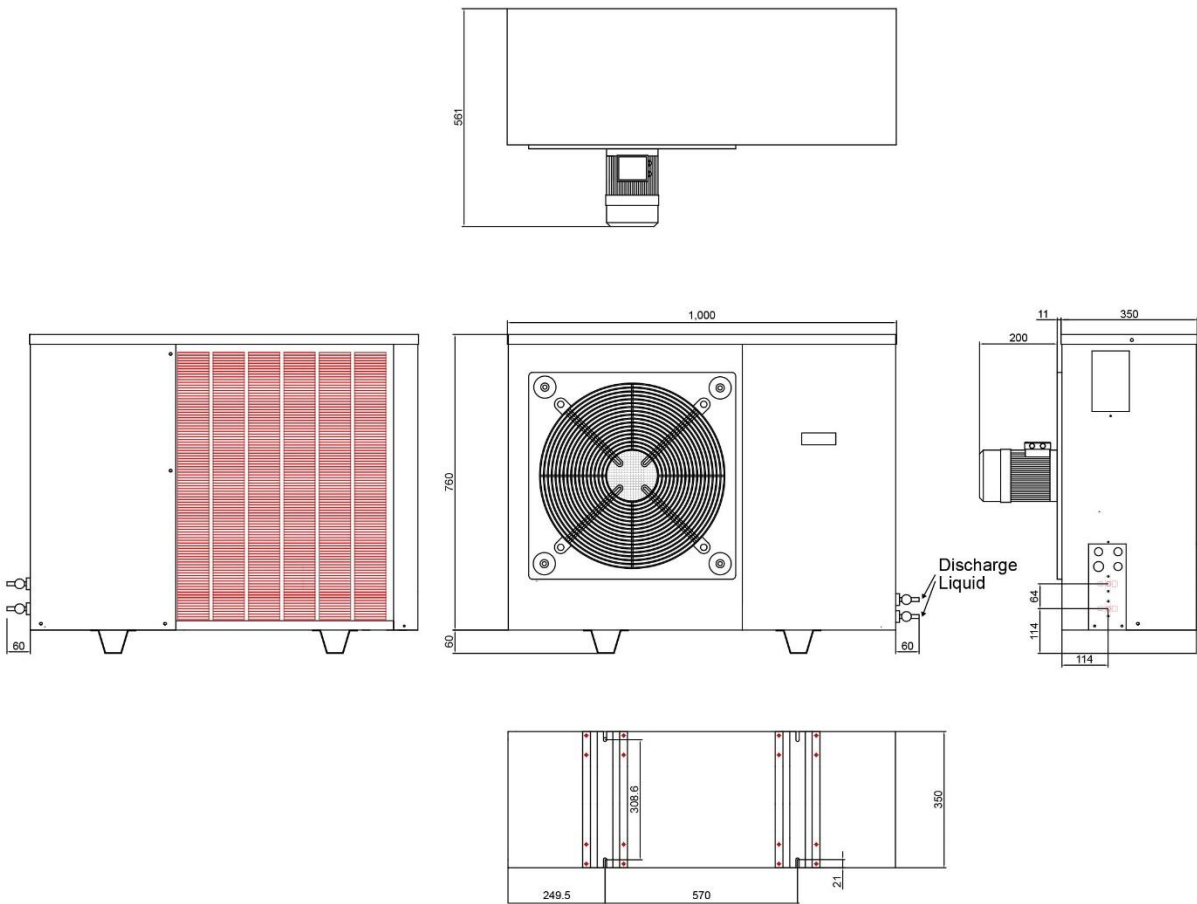

MCUA 130-165

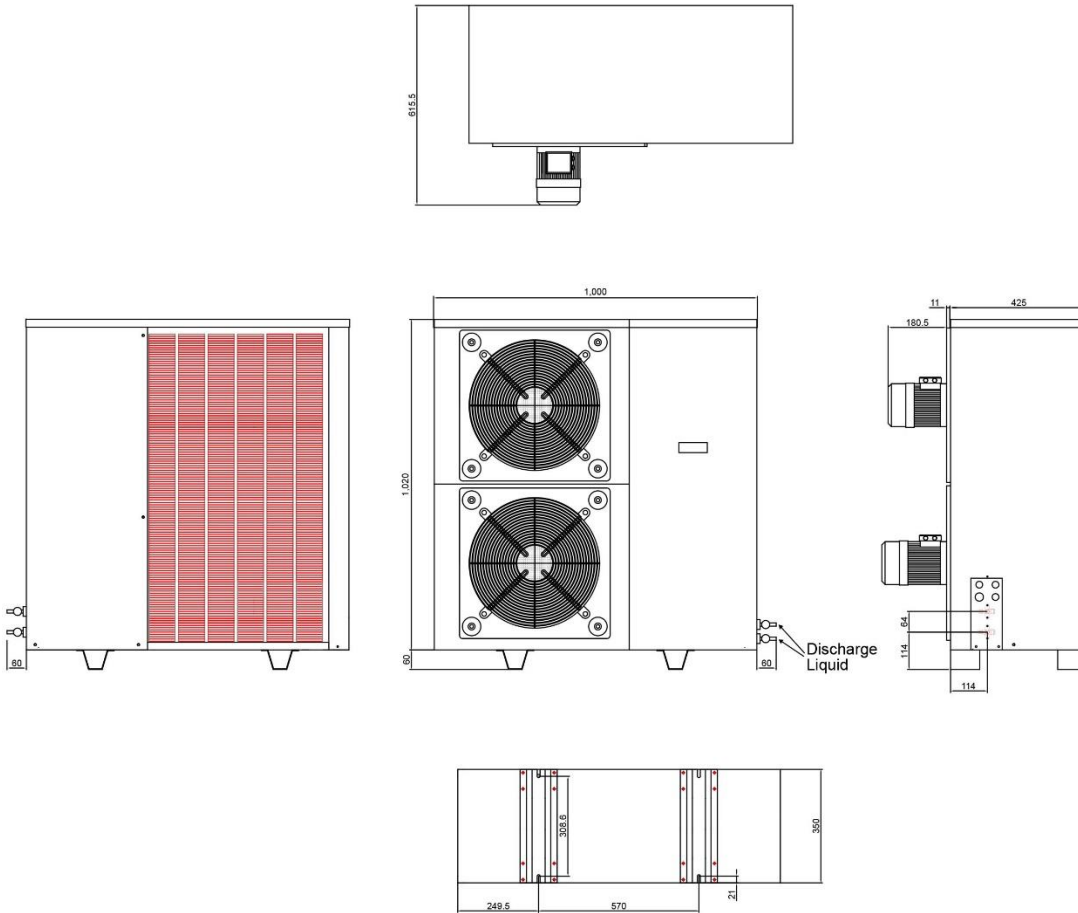

MCUA 180-200

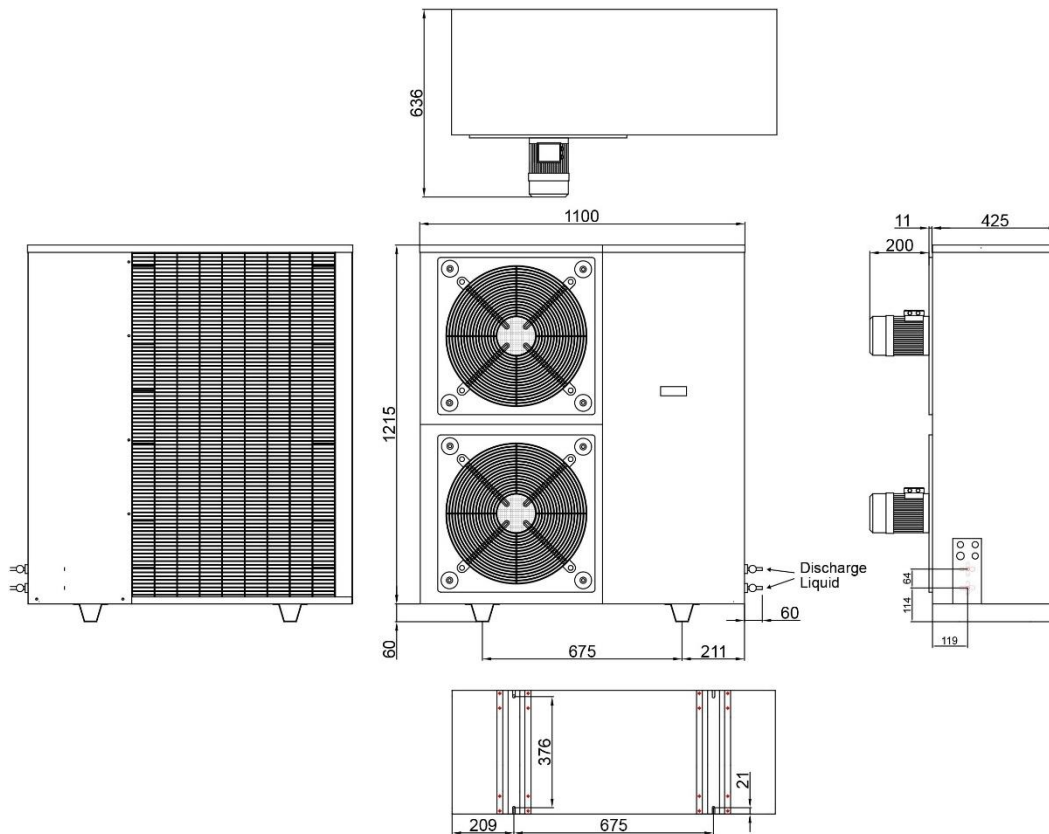

MMC 15-180

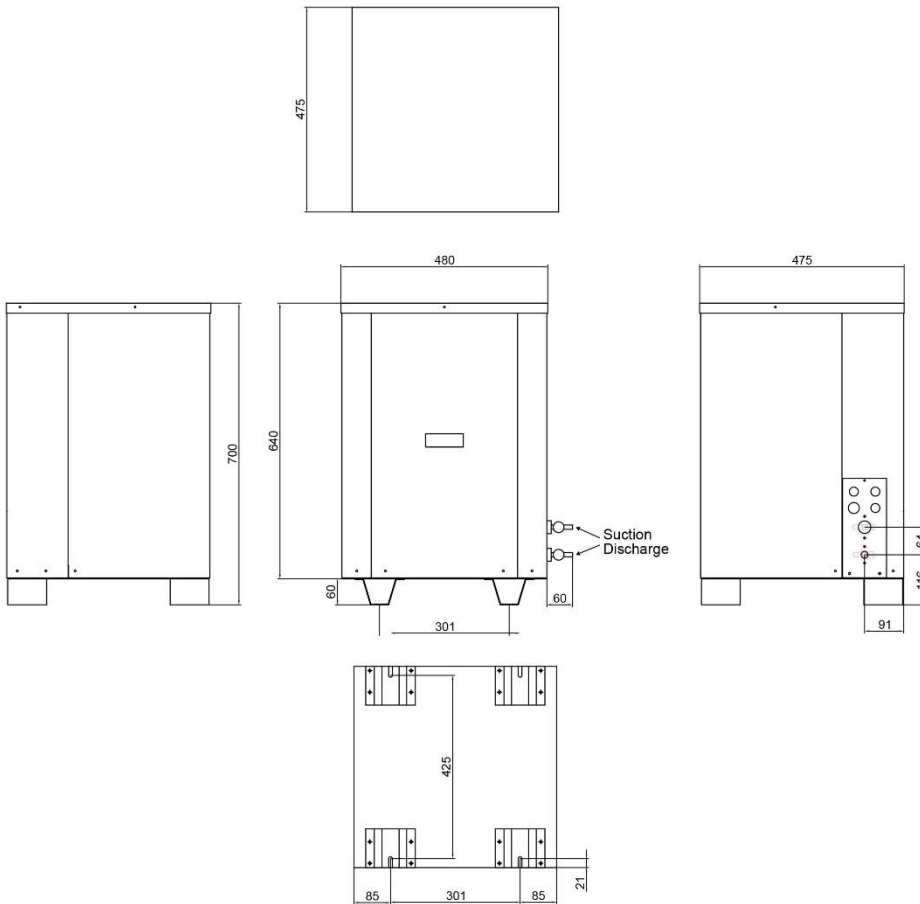

PIPEWORK

CALCULATING EQUIVALENT LENGTHS

The effects of bends and fittings must be taken into account. The table on top of page 5 covers the fittings most likely to be encountered in installation.

ACTUAL PIPE LENGTH + TOTAL EQUIVALENT FITTING LENGTHS = TOTAL EQUIVALENT LENGTH

FITTING LOSSES in equivalent straight lengths of pipes (m)

FITTING	PIPE SIZE (outside diameter in inches)						INSTALLERS TABLE	
	3/8	1/2	5/8	3/4	7/8	1 1/8	Nº OF FITTINGS	EFFECTIVE LENGTH
45° Bend	0.12	0.15	0.18	0.21	0.24	0.30		
90° Bend R/d = 1	0.37	0.43	0.49	0.55	0.61	0.79		
90° Bend R/d = 2	0.24	0.27	0.30	0.37	0.43	0.52		
180° Bend C/d = 1	0.73	0.91	1.10	1.28	1.46	1.83		
180° Bend C/d = 2	0.46	0.55	0.64	0.76	0.85	1.07		
90° Elbow	0.67	0.85	1.04	1.25	1.46	1.89		
R = Radius of bend	d = Diameter of tube		C = Centres of bend			TOTAL = _____		

Pipe sizes are based on:

- Minimum of 2.5 m/s (500 fpm) suction gas velocity for horizontal or downflow.
- Minimum of 5.0 m/s (1000 fpm) suction gas velocity for upflow.
- Maximum of 20.0 m/s (4000 fpm) suction gas.

Where vertical risers exceed 3m, oil traps must be formed in the pipe. This will help ensure that oil returns to the compressor. Typically fit an oil trap every 3m with a trap at the bottom of the riser.

The equivalent pipe run should be 45m maximum, including a maximum lift of 7.5m. Fully insulate the suction line. Ensure the suction pipe is insulated well over the drain tray at the indoor unit. Liquid lines should be routed to avoid hot areas. This prevents flash gas forming, which may result in erratic control of liquid refrigerant to the evaporator.

GOOD PRACTICE

- Keep pipe runs as short as possible.
- Avoid sharp bends
- Fully insulate both suction and expansion including mechanical connections
- Try to avoid running pipes through hot areas.

PIPE SIZES

MMC	MCUA	Suction				Discharge				Liquid	
		0-6m	6-15m	15-21m	21-45m	0-6m	6-15m	15-21m	21-45m	0-21m	21-45m
30	30	1/2	5/8	5/8	5/8	1/2	1/2	5/8	5/8	1/4	3/8
40	40	1/2	5/8	5/8	3/4	1/2	5/8	5/8	3/4	3/8	3/8
50	50-80	1/2	5/8	3/4	3/4	1/2	5/8	3/4	3/4	3/8	1/2
60	50-80	5/8	3/4	3/4	7/8	5/8	5/8	3/4	7/8	3/8	1/2
80	50-80	5/8	3/4	3/4	7/8	5/8	3/4	3/4	7/8	3/8	1/2
90	90-100	5/8	3/4	3/4	7/8	5/8	3/4	3/4	7/8	3/8	1/2
100	90-100	3/4	7/8	7/8	1 1/8	5/8	3/4	3/4	7/8	3/8	5/8
130	130-165	3/4	7/8	7/8	1 1/8	3/4	3/4	7/8	1 1/8	1/2	5/8
150	130-165	3/4	7/8	7/8	1 1/8	3/4	7/8	7/8	1 1/8	1/2	5/8
165	130-165	3/4	7/8	1 1/8	1 1/8	3/4	7/8	1 1/8	1 1/8	1/2	5/8
180	180-200	7/8	1 1/8	1 1/8	1 3/8	3/4	7/8	1 1/8	1 1/8	1/2	5/8
200	180-200	7/8	1 1/8	1 1/8	1 3/8	7/8	1 1/8	1 1/8	1 3/8	1/2	5/8

PIPE CONNECTIONS

MMC

Model	30	40	50	60	80	90	100	130	150	165	180	200
Discharge	1/2	1/2	1/2	5/8	5/8	3/4	3/4	3/4	3/4	3/4	3/4	3/4
Suction	1/2	1/2	1/2	5/8	5/8	3/4	3/4	3/4	3/4	3/4	3/4	3/4

MCUA

Model	30	40	50-80	90-100	130-165	180-200
Discharge	1/2	1/2	5/8	3/4	3/4	3/4
Liquid	3/8	3/8	1/2	1/2	1/2	1/2

INTERCONNECTING PIPEWORK

1. MMC and MCUA units have a low pressure charge of N₂, which may be safely released into the atmosphere before connection. The service valves on the units should remain closed (IN, fully clockwise) until pipework has been fitted, to avoid unnecessary moisture ingress.
2. Connecting the pipework
 - a. Remove the flare nuts from the suction, discharge and liquid service valves.
 - b. Ensure that the suction line is fully insulated: if an expansion line is used this should also be fully insulated.
 - c. Place the flare nuts over the incoming pipework and flare the pipe ends. The use of a little refrigeration oil on the flaring tool will help.
 - d. Connect the pipework between the units. Do not leave pipe ends, valves etc. open to the atmosphere.
R407C is very hygroscopic, and will absorb damaging levels of moisture if left open.

Always use two spanners when tightening the flare nuts to avoid twisting the pipes. Use a small amount of refrigerant oil on the mating surfaces.

- e. Sight glasses and filter driers are not necessary, but if required should be fitted between the outdoor unit liquid shut off valve and the expansion device.

EVACUATING

With the valves closed, connect a vacuum pump to the service ports on the outdoor unit valves. Evacuate the interconnecting pipework and indoor unit to 1000 microns (1 Torr) or better. Allow this to be held for a minimum of 15 minutes.

1. Release the nitrogen holding charge in the indoor and outdoor units to atmosphere. Open the valves (hex drive fully out) using a 5mm Allen key. Connect a vacuum pump to the service ports on the outdoor unit valves and evacuate the system to 1000 microns (1 Torr) or better and allow to be held for a minimum of 15 minutes.
2. Replace the caps on the service ports, (torque to 25NM).

REFRIGERANT

R407C Refrigerant charge for 3mm liquid line MMC

30	1000
40	1240
50	1690
60	2000
80	1880
90	2060
100	2520
130	4170
150	4170
165	4540
180	4640
200	5480

Charge in g per extra meter of liquid line

1/4	20
3/8	50
1/2	80
5/8	110

KVC Suction Pressure Regulators

Turning clockwise gives higher pressure and turning counter clockwise gives lower pressure. Set the suction pressure to between 3.5 and 4 bar.

After the system has been in normal operation for a time, fine adjustment is necessary. Always use a pressure gauge when making fine adjustments.

Remember to always replace the protective cap on the setting screw after final setting

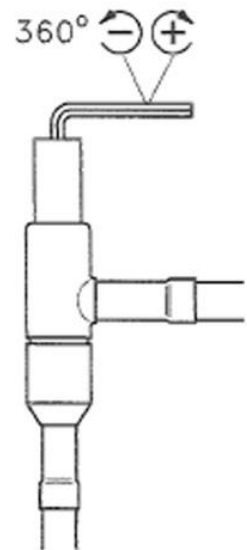

1. FANS

The fans fitted to MCUA units can be used in potentially explosive environments. Said fans have the CE mark in the plate of characteristics and comply with the following:

- ATEX 94/9/CE Directive.
- 98/37/CE Machinery Directive.
- Including the following standards:
 - EN 13463-1; Non-electrical equipment, used in potentially explosive environments.
 - EN 1127-1; Explosive environments. Prevention and protection against explosions.
 - EN ISO 12100-1; Machinery safety. Basic concepts.
 - EN ISO 12100-2; Machinery safety. Basic concepts.
 - EN 294; Machinery safety. Safety distance to avoid touching dangerous areas with the top limbs.
 - ISO 13852; Machinery safety. Safety distance to avoid touching dangerous areas with the top limbs.
 - UNE 100250; (ISO 12499) Industrial fans. Mechanical safety of fans.
 - ISO 3744; Acoustics. Determination of sound power levels.
 - ISO 1940-1; Mechanical vibration. Balancing quality.
 - ISO 10816-1; Mechanical vibration. Evaluation of machine vibrations.

2. Validity

These instructions are valid for the units manufactured by Marstair, with the construction required to operate in potentially explosive environments (Ex II 2 G).

3. Previous Verifications

We advise that you check the requirements related to methods of protection in explosive environments, for example:

- a) Group of gases
- b) Type of temperature

Temperature class	Ignition temperature for gas / steam °C	Maximum temperature allowed in the equipment °C
T4	>135 <200	135

The maximum temperature is calculated with a room temperature of 40°C

The units are not suitable for use below -20°C

SERVICING

WARNING

The servicing activities will only be carried out after it has been turned off.

MCUA and MMC have a functional design and robust construction. Therefore, they do not require much servicing activities for a correct operation.

The fan motor metallic parts are protected against rust with a rustproof paint finish (free from steel rust) and are dried at a temperature of 200°C in a furnace after the degreasing and phosphate coating process.

A series of external agents require the observance of a set of precautions to obtain the best performance of the rotating equipment.

1. Motor

The motor must be clean at all times, since large quantities of dust particles between the cooling fins or air inlets can overheat the motor.

The connections of the terminal box should be checked (in case they can be easily accessed) to verify the correct tension of the bolts and screws.

2. Propellers

The propellers are balanced dynamically in accordance with the following standard: ISO 1940-1 and quality level Q6,3.

A high level of vibration should be avoided at all times. The best method to define the variations encountered in the smooth operation of the equipment is the measurement of the mechanical vibrations in bearings and drive motors. The safest method to define the said vibrations is the comparison of values measured throughout a long period of time. If there is a big variation in the values, the possible causes should be studied, for example: dirt in the propeller or turbine. In this case, the said elements should be cleaned and the unit should be balanced again.

The propellers and turbines should be cleaned periodically, since the dust and residues deposited in its blades or fins decrease the performance and progressively unbalance the equipment, which affects the operation.

Check for any unwanted interference caused by dust or residues between the rotating element (propeller or turbine) and fixed or enveloping parts of the motor.

These operations must be carried out with the correct equipment. A standardised extraction device should be used to disassemble the propeller or turbine. Specific tools should be used to change bearings, ensuring the axis or bearing covers are not damaged.

3. Bearings

To avoid early faults and stops, each bearing should be checked regularly. Avoid the presence of unwanted elements, dirt and humidity.

In delicate machines, control the detection of noise and temperature increases, which might result in serious operation problems.

4. Heat Exchanger

The heat exchanger should be cleaned regularly to maintain system performance

WIRING DIAGRAM

MCUA+MMC 30 - 200 3PH

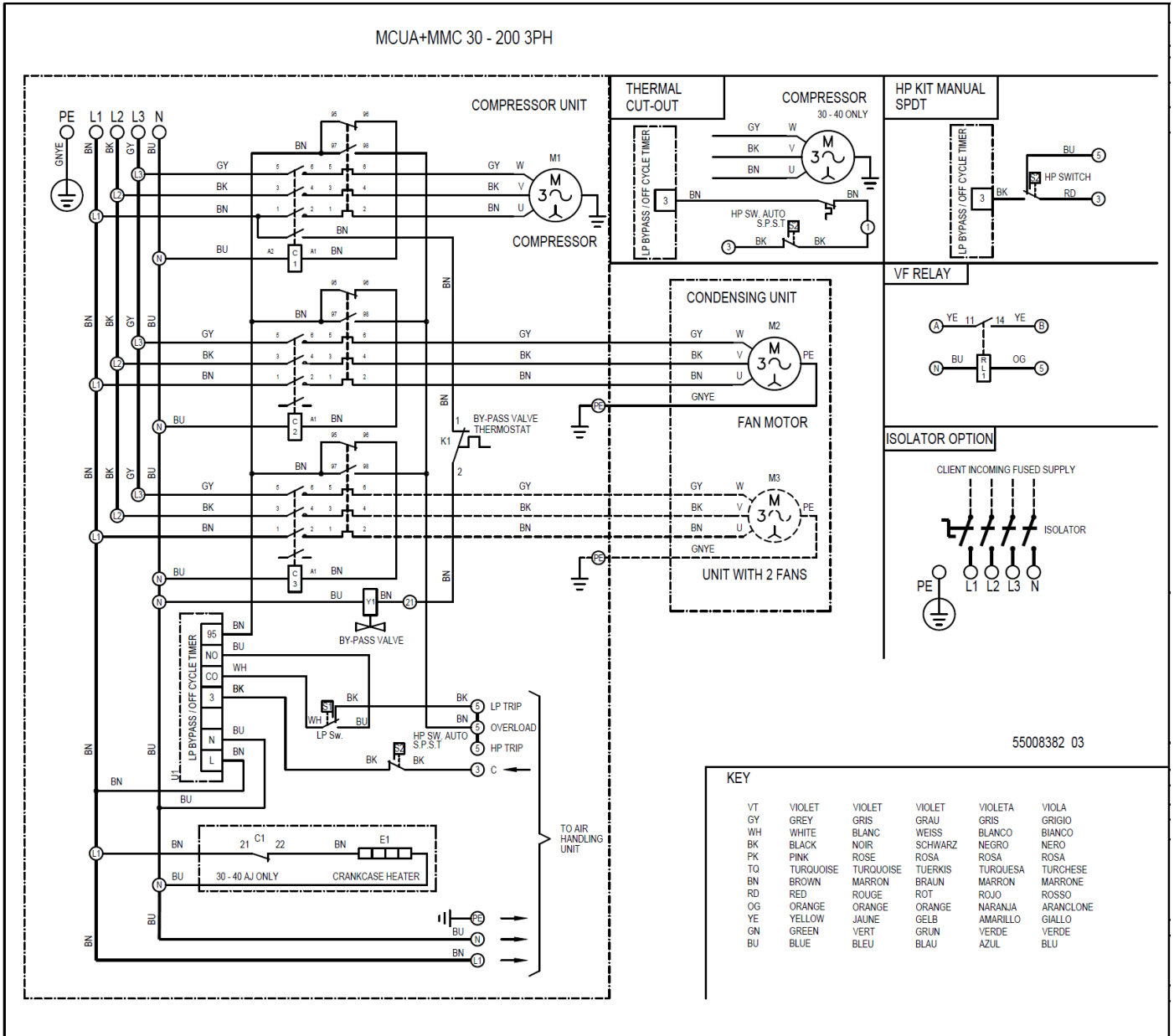

KEY

VT	VIOLET	VIOLET	VIOLET	VIOLETA	VIOLA
GY	GREY	GRIS	GRAU	GRIS	GRIGIO
WH	WHITE	BLANC	WEISS	BIANCO	BIANCO
BK	BLACK	NOIR	SCHWARZ	NEGRO	NERO
PK	PINK	ROSE	ROSA	ROSA	ROSA
TO	TURQUOISE	TURQUOISE	TUERKIS	TUROUESA	TURCHESE
BN	BROWN	MARRON	BRAUN	MARRON	MARRONE
RD	RED	ROUGE	ROT	ROJO	ROSSO
OG	ORANGE	ORANGE	ORANGE	NARANJA	ARANCLONE
YE	YELLOW	JAUNE	GELB	AMARILLO	GIALLO
GN	GREEN	VERT	GRUN	VERDE	VERDE
BU	BLUE	BLEU	BLAU	AZUL	BLU

MCUA+MMC 30 - 200 3PH - N

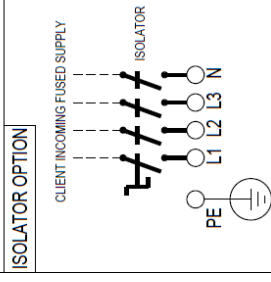
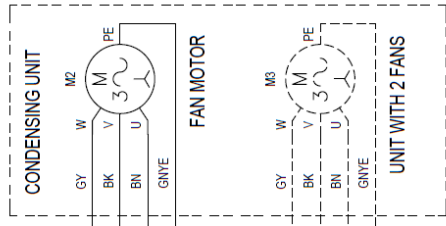
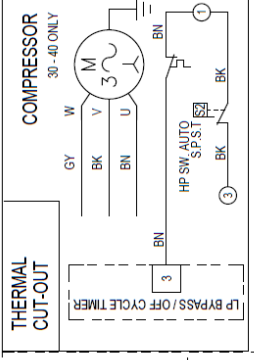
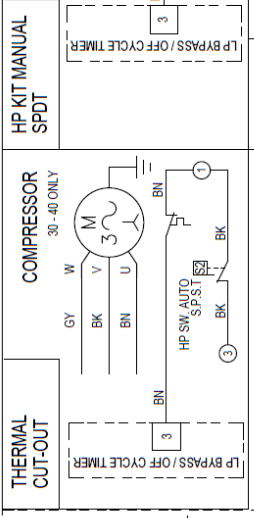
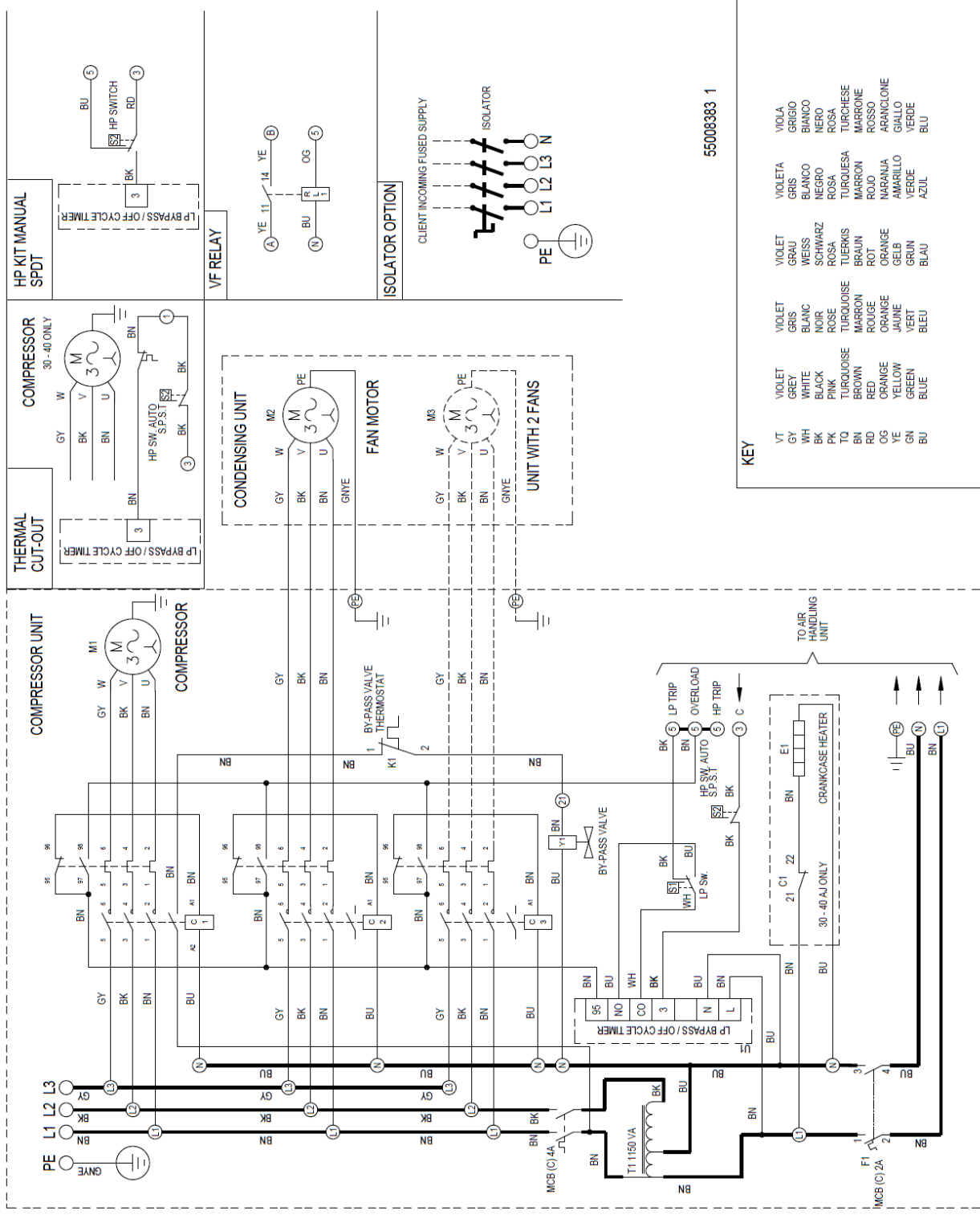

55008383 1

KEY

VT	VIOLET	VIOLET	VIOLET
GY	GREY	GRAU	GRIGIO
WH	WHITE	WEISS	BIANCO
BK	BLACK	SCHWARZ	NERO
PK	PINK	ROSA	ROSA
TO	TURQUOISE	TURKIS	TURCHESE
BN	BROWN	BRAUN	MARRONE
RD	RED	ROUGE	ROSSO
OG	ORANGE	ORANGE	ARANCLONE
YE	YELLOW	JAUNE	GIALLO
GN	GREEN	VERT	VERDE
BU	BLUE	BLEU	AZUL