

CC 600 Ceiling Cassette Evaporators

CC600 CEILING CASSETTE

DESIGNED FOR RAPID INSTALLATION AND EASY MAINTENANCE, THE CC600 IS IDEAL IN PROCESS OR MATERIAL COOLING APPLICATIONS AT LOW TEMPERATURES

Units are available with a range of cooling duties from 2 to 6kW and a range of heating duties. The lightweight, one-piece, removable chassis allows total access to all mechanical and electrical connections. The units deliver long air throws, low sound levels and come with control options; Electromechanical Infrared 'L' and Electronic 'E'.



Specification

- Low sound levels
- Long air throws
- 3 or 4 way air discharge
- De-Ice thermostat
- Removable, lightweight, one piece chassis
- Integral, easy to clean, drain tray
- Easy filter access and long life washable filters
- Modern, slim, square fascia with rounded corners
- All services accessed from one corner
- Coil cleaning from all sides
- Fan guard for safety
- Fresh air inlet provision and branch duct provision
- Motor speed range selection to suit application
- Lift pump or condensate pump
- Electric heating (2kW) option
- Suitable for use with R407C, R404A, R410A and R134A for cooling only applications
- Suitable for heat pump applications with R407C
- Can be matched with Marstair R407C CKC+ cooling only condensers and MHPUL(E) heat pumps
- Cooling down to 10°C at -2.5°C evaporating temperature (Electromechanical Control only)
- The CC 'E' can be networked as either a multi-split or group control system



Technical Information

R407C

Performances with thermal expansion valve set at 5°C superheat

MODEL	AIR ON °C	HUMIDITY % RH	EVAPORATING TEMPERATURE °C												
			-2.5		0		2.5		5		7.5		10		
			TOTAL	SENS	TOTAL	SENS	TOTAL	SENS	TOTAL	SENS	TOTAL	SENS	TOTAL	SENS	
LOW FAN SPEED	20	10	70	1.04	0.77	0.79	0.63	0.54	0.50	0.35	0.35	0.18	0.18	-	-
		12.7	70	1.34	0.90	1.10	0.77	0.84	0.65	0.57	0.51	0.37	0.37	0.19	0.19
		15	70	1.62	1.01	1.38	0.88	1.12	0.76	0.85	0.64	0.55	0.51	0.36	0.36
		18	60	1.83	1.20	1.58	1.08	1.33	0.96	1.06	0.84	0.76	0.71	0.57	0.57
		21	50	2.00	1.40	1.75	1.28	1.50	1.17	1.22	1.05	0.95	0.95	0.78	0.78
	40	10	70	1.53	1.10	1.17	0.89	0.79	0.68	0.48	0.48	0.24	0.24	-	-
		12.7	70	1.98	1.30	1.61	1.10	1.24	0.90	0.84	0.70	0.50	0.50	0.26	0.26
		15	70	2.38	1.46	2.02	1.26	1.64	1.07	1.25	0.88	0.82	0.68	0.48	0.48
		18	60	2.68	1.72	2.32	1.53	1.94	1.34	1.54	1.14	1.12	0.95	0.76	0.76
		21	50	2.92	1.98	2.56	1.79	2.19	1.60	1.79	1.42	1.37	1.22	1.04	1.04
	60	10	70	1.83	1.29	1.40	1.03	0.95	0.78	0.54	0.54	0.27	0.27	-	-
		12.7	70	2.36	1.54	1.92	1.29	1.48	1.05	0.80	0.64	0.57	0.57	0.30	0.30
		15	70	2.83	1.74	2.41	1.50	1.96	1.26	1.49	1.02	0.98	0.78	0.54	0.54
		18	60	3.18	2.05	2.76	1.80	2.32	1.57	1.85	1.33	1.34	1.09	0.86	0.86
		21	50	3.47	2.34	3.05	2.10	2.61	1.86	2.14	1.63	1.64	1.39	1.18	1.18
MEDIUM FAN SPEED	20	10	70	1.18	0.90	0.90	0.74	0.62	0.62	0.42	0.42	0.21	0.21	-	-
		12.7	70	1.54	1.04	1.25	0.90	0.96	0.76	0.65	0.62	0.44	0.44	0.23	0.23
		15	70	1.95	1.20	1.66	1.06	1.38	0.93	1.06	0.79	0.73	0.66	0.49	0.49
		18	60	2.09	1.39	1.81	1.26	1.51	1.14	1.20	1.00	0.88	0.88	0.68	0.68
		21	50	2.29	1.64	2.00	1.51	1.70	1.38	1.39	1.26	1.13	1.13	0.93	0.93
	40	10	70	1.89	1.38	1.44	1.12	0.98	0.87	0.62	0.62	0.31	0.31	-	-
		12.7	70	2.44	1.62	1.98	1.38	1.53	1.14	1.03	0.90	0.64	0.64	0.34	0.34
		15	70	3.10	1.88	2.65	1.64	2.18	1.42	1.70	1.18	1.17	0.94	0.70	0.70
		18	60	3.47	2.21	3.02	1.98	2.56	1.75	2.06	1.53	1.54	1.30	1.07	1.07
		21	50	3.62	2.49	3.17	2.26	2.71	2.04	2.22	1.82	1.69	1.58	1.35	1.35
	60	10	70	2.36	1.69	1.80	1.37	1.22	1.05	0.73	0.73	0.37	0.37	-	-
		12.7	70	3.04	2.01	2.48	1.69	1.90	1.38	1.30	1.07	0.76	0.76	0.40	0.40
		15	70	3.66	2.26	3.10	1.95	2.53	1.65	1.91	1.34	1.26	1.04	0.73	0.73
		18	60	4.11	2.66	3.56	2.35	2.99	2.06	2.38	1.75	1.73	1.46	1.16	1.16
		21	50	4.49	3.06	3.94	2.75	3.37	2.46	2.76	2.17	2.10	1.86	1.58	1.58
HIGH FAN SPEED	20	10	70	1.33	1.03	1.01	0.86	0.72	0.72	0.49	0.49	0.25	0.25	-	-
		12.7	70	1.72	1.19	1.40	1.04	1.07	0.89	0.74	0.74	0.51	0.51	0.27	0.27
		15	70	2.08	1.33	1.76	1.18	1.42	1.04	1.07	0.88	0.74	0.74	0.50	0.50
		18	60	2.34	1.61	2.02	1.46	1.70	1.33	1.34	1.18	1.03	1.03	0.80	0.80
		21	50	2.57	1.90	2.25	1.77	1.91	1.63	1.54	1.54	1.32	1.32	1.10	1.10
	40	10	70	2.29	1.70	1.74	1.40	1.18	1.11	0.78	0.78	0.39	0.39	-	-
		12.7	70	2.96	1.99	2.41	1.71	1.85	1.43	1.25	1.14	0.82	0.82	0.43	0.43
		15	70	3.57	2.23	3.02	1.96	2.46	1.69	1.86	1.41	1.22	1.13	0.79	0.79
		18	60	4.02	2.66	3.47	2.39	2.91	2.13	2.31	1.86	1.66	1.58	1.26	1.26
		21	50	4.40	3.10	3.86	2.85	3.29	2.59	2.69	2.33	2.10	2.10	1.74	1.74
	60	10	70	2.98	2.18	2.26	1.77	1.54	1.38	0.97	0.97	0.49	0.49	-	-
		12.7	70	3.84	2.56	3.13	2.18	2.40	1.79	1.63	1.41	1.02	1.02	0.53	0.53
		15	70	4.62	2.88	3.92	2.50	3.19	2.14	2.42	1.76	1.58	1.38	0.98	0.98
		18	60	5.22	3.40	4.50	3.03	3.78	2.67	3.00	2.30	2.17	1.94	1.56	1.56
		21	50	5.70	3.94	4.98	3.58	4.26	3.22	3.48	2.86	2.66	2.50	2.13	2.13

Technical Information

Airflows

RANGE 3			LOW SPEED	MEDIUM SPEED	HIGH SPEED
RANGE 2		LOW SPEED	MEDIUM SPEED	HIGH SPEED	
RANGE 1	LOW SPEED	MEDIUM SPEED	HIGH SPEED		
600 (ALL)	M ³ /S	M ³ /S	M ³ /S	M ³ /S	M ³ /S
20	0.12	0.146	0.173	0.209	0.256
40	0.12	0.146	0.173	0.209	0.256
60	0.12	0.146	0.173 </tr		

600 Cassette Air Throws

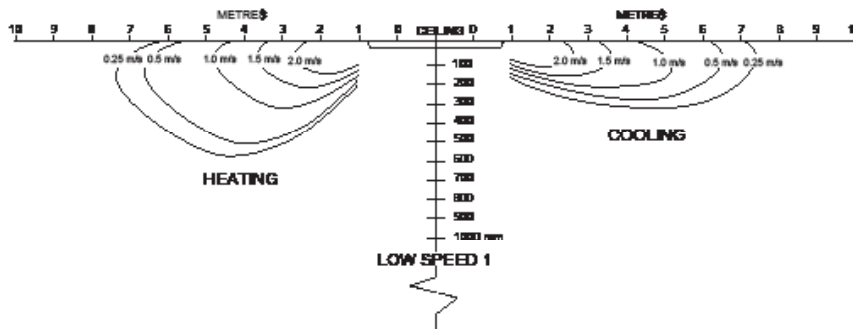
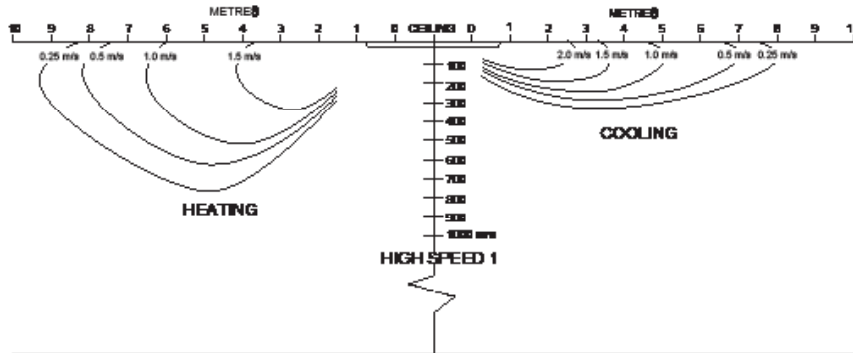

Sound Power & Sound Pressure Speed 1 = Lowest, Speed 5 = Highest

600 (ALL)	SPEED	SOUND POWER LEVELS							SOUND PRESSURE LEVELS	
		FREQUENCY Hz							dBA	NC
		125	250	500	1K	2K	4K	dBA		
20	1	56.3	48.3	45.5	39.0	36.6	35.8	47	26	18
	2	58.8	51.9	50.2	44.9	41.4	37.5	52	31	23
	3	61.6	57.8	55.6	53.8	48.5	44.4	58	37	31
	4	62.9	60.1	57.6	56.3	51.3	46.8	61	40	34
	5	67.0	65.6	62.9	61.3	57.6	53.0	66	45	39
40	1	55.7	49.7	46.4	39.2	37.2	35.7	48	27	19
	2	57.5	53.6	50.9	45.1	42.3	39.8	52	31	24
	3	61.9	59.0	56.2	54.2	48.9	44.2	59	38	32
	4	63.1	62.0	58.3	56.6	51.6	46.7	61	40	34
	5	68.0	67.3	63.5	61.9	57.5	52.8	67	46	40
60	1	55.5	51.1	47.8	41.8	41.1	40.0	50	29	22
	2	58.8	54.8	52.0	47.5	46.2	42.3	54	33	26
	3	62.1	59.2	56.4	53.6	49.9	43.2	59	38	31
	4	64.1	61.2	58.5	55.6	51.7	45.4	60	39	33
	5	69.4	66.5	63.1	60.6	56.5	51.6	66	45	39

Sound Power Levels are obtained in conformance with BS4196:Part 5: 1981. Values are shown in dB with a standard reference of 1pW.
 Sound Pressure Levels are dB relative to 2x10⁻⁵N/m and are calculated from results measured in anechoic conditions.
 Values relate to a position of 3m away from the centre line of the unit, 1m down.

Technical Information

Optional Electrical Heating (for air conditioning and heat pump systems)

MODEL	AT 240V 50Hz (kW)	AT 230V 50Hz (kW)
20	2.0	1.84
40	2.0	1.84
60	2.0	1.84

Unit Dimensions & Weight (Unpacked with fascia fitted)

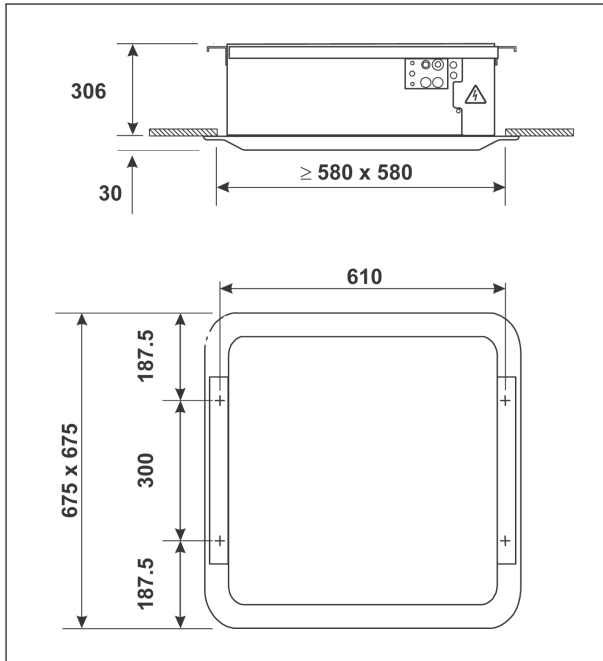

DIMENSIONS AND WEIGHTS			
MODEL	20	40	60
HEIGHT (mm)	335	335	335
WIDTH (mm)	675	675	675
DEPTH (mm)	675	675	675
WEIGHT (kg)	21	23	25

Installation

THE CC600 IS DESIGNED FOR RAPID INSTALLATION AND EASY MAINTENANCE.

The one-piece removeable chassis allows easy access to all components for cleaning and this makes it an excellent solution for medical environments.

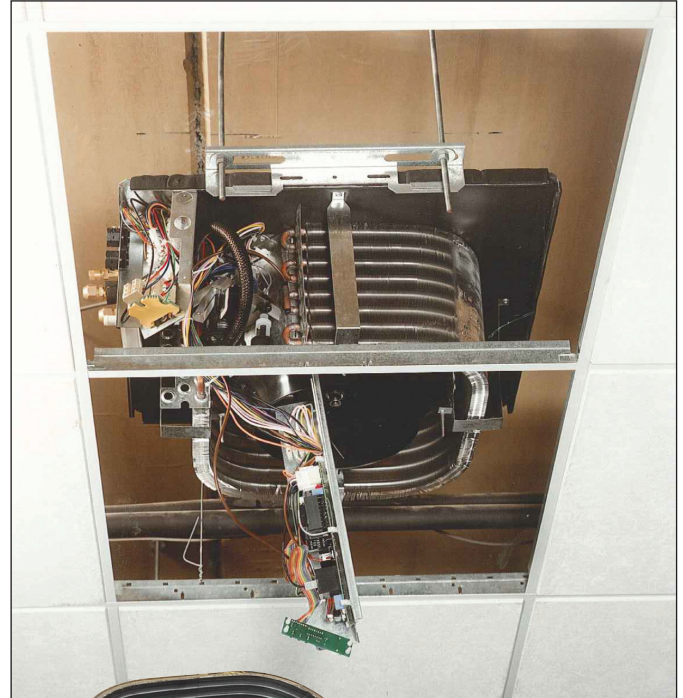

Single Diameter Fan (CC600)
All services at one corner

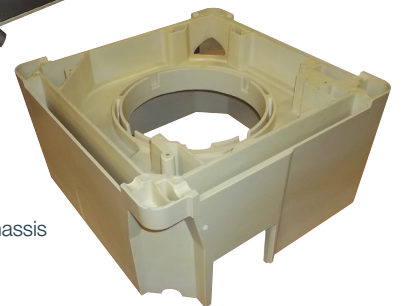

Removable Lightweight Chassis

T: 01484 405 666
E: sales@marstair.com

TEV has earned management system accreditations – BSI 14001: 2015 Environmental Management and BSI 9001: 2015 Quality Management.



In partnership with



Part No: 06617595-09