

## DX (H) Fan Coil Unit Evaporators

**DXT  
R407C, R410A, R404A, R134A  
COOLING ONLY**

**THE MARSTAIR DXT SERIES UNITS COMPRISE OF VERTICAL WALL MOUNTED AND HORIZONTAL CEILING OR VOID MOUNTED DX FAN COIL UNITS PROVIDING RELIABLE INTERNAL CLIMATE CONTROL WHEN COOLING OR HEATING IS REQUIRED. CAPACITIES RANGE FROM 0.5KW TO 10KW.**

This new product is available as a standard chassis unit for void mounting or with a stylish cabinet for surface mounting on walls or ceilings. Chassis units may be free blow or ducted.



### Specification

- Quiet in use - room occupants will appreciate the very low sound levels
- Class 'O' fire rated thermal and acoustic insulation
- Compact, low energy motors fitted to forward curved centrifugal fans
- All models are available with various air inlet and discharge combinations
- Units are available with AC or EC/DC fan motors. AC fans are fitted with a multi-tap transformer providing up to six fan speeds, whilst EC/DC fans may be used for variable speed control via a potentiometer or a 0-10V output from a digital controller
- Units are easily and safely installed using the keyhole slots in the back panel to mount them on a wall or ceiling, or to hang from drop rods
- Various control options are available, ranging from simple hard wired wall mounted controllers to full BMS compatibility to meet individual project requirements
- Servicing is made easy with simple access to the standard EU2 filter, the fan assemblies and any unit mounted controls.
- Chassis and cased versions providing ducted or free blow options.

# Specification

## Cabinet

The optional outer cabinet is a single piece, hot dipped galvanised sheet steel wrap around section PVC pre-coated to ensure high resistance to corrosion. The standard colour is RAL9010 White. Cabinets are fitted as standard with 100mm wide ABS moulded grilles in light grey (RAL7035). Nylon discharge grilles are fitted to units with electric heaters.

## Fans

Units may be fitted with AC or EC/DC fan motor assemblies.

AC motors are totally enclosed multi speed, split capacitor start, thermally protected type and have sealed for life bearings. A multi-tap transformer is fitted for speed selection. Motors will be single or double shafted depending upon unit size and are mounted in a cradle with resilient rubber mounts to prevent noise and vibration.

Fans are forward curved double inlet centrifugal type with fully balanced aluminium impellers fitted to the motor shaft(s). Fan scrolls are manufactured from galvanised steel and are mounted directly onto the fan plate.

EC/DC fan motor assemblies comprise direct drive, forward curved centrifugal fans with electronically commutated motors; fan scrolls are manufactured from galvanised sheet steel and are fitted with aluminium impellers. EC fan motor assemblies provide a variable speed option of 0-100% control via an additional potentiometer fitted to the unit or a 0-10V output from a specified controller

## Chassis

Manufactured from galvanised sheet steel with sufficient strengthening folds and forms to give a robust, vibration free assembly. The chassis is riveted and spot welded for rigidity.

## Filters

Filters are manufactured from EU2 or EU3 continuous filament fire resistant media fitted within an aluminium frame and supported by a fine mesh.

## Coils

Cooling coils are manufactured from seamless copper tube, mechanically expanded onto aluminium fins having die formed collars to maximise contact and optimise heat transfer.

## Access

Access to filters is from the front or bottom of the unit depending upon the configuration. Coils and fans are accessed by removal of a single panel on the chassis unit and by removal of the cabinet on the cases unit.

## Ducting

Chassis units may be fitted with a spigot suitable for connection to either a rectangular spigot or multiple circular spigots of 160mm or 200mm Ø on inlet and discharge.

## Insulation

Units are lined with a CFC & HFC free class 'O' open cell expanded foam insulation for thermal and acoustic performance with a maximum thermal conductivity of 0.045 W/mk. Adhesive backing is a light and ageing resistant synthetic resin with high temperature resistance.

## EC/DC Motors

In these days of increasing energy costs and climate change it is incumbent on all of us that the most efficient and cost effective solutions are employed in every design.

One of the tools available to the designer to reduce energy consumption is to use electronically commutated, direct current (ec/dc) motors. Not only do these motors use substantially less energy than their ac counterparts, they are also infinitely speed controllable. This latter feature enables the motor speed to be adjusted with relationship to occupancy and temperature and ensures that, for the majority of their operation, they are running at the minimum speed required for correct comfort conditions. The net effect is to further substantially reduce energy use and hence running cost when compared to the ac counterpart.

### Typical Comparative Figures Per Fan

	ac Motor	ec/dc Motor
Power input, speed 3 @ 30Pa	118W	50W
Specific Fan Power	0.75	0.31

Ec/dc motors are available as an option on all Marstair fan coils.

Marstair include in the package all filters required to ensure compliance with European regulations relating to electromagnetic emissions.

For further information please consult our Technical Sales Department on 01484 405666.

## Configuration options

Vertical Cased Units

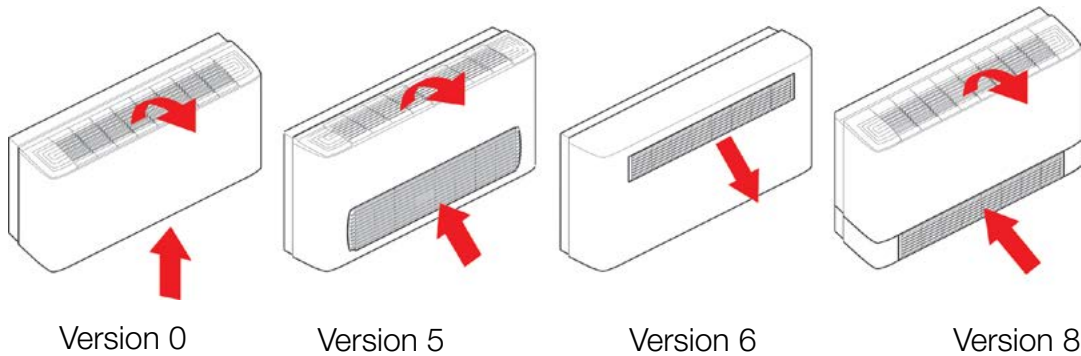

## Horizontal Cases Units

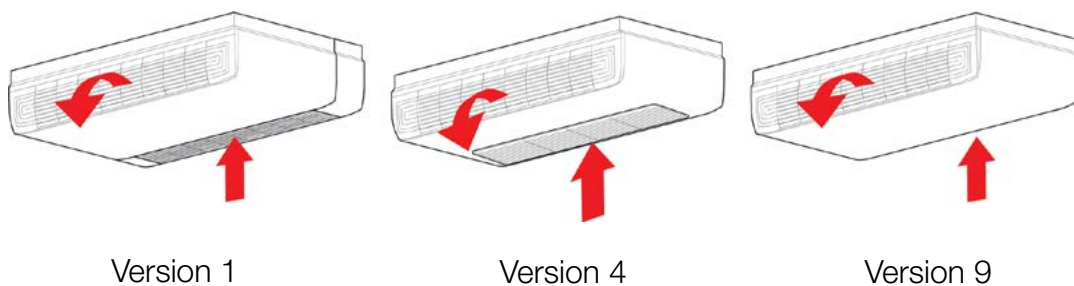

## Chassis Units - Standard

Void mounted unit available as free blow or with optional spigot arrangements

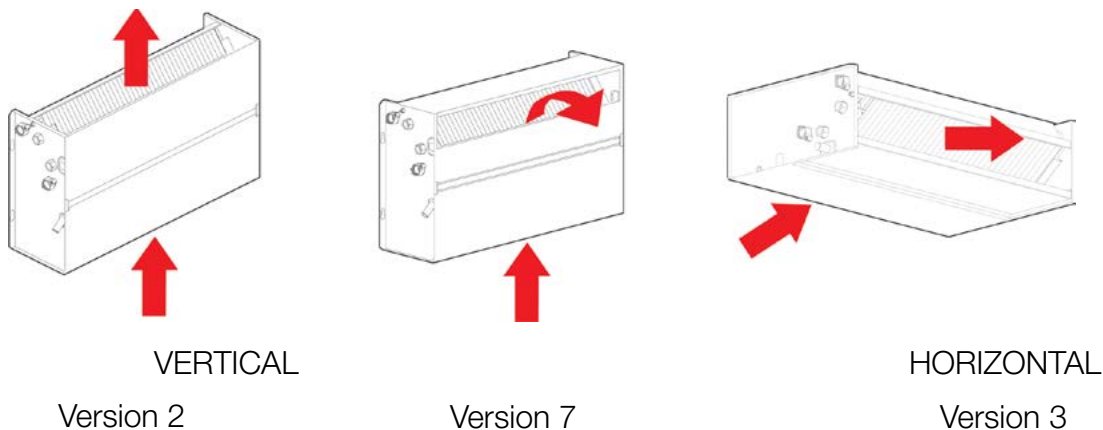

## Chassis Units - Drain Tray / Electrics Box

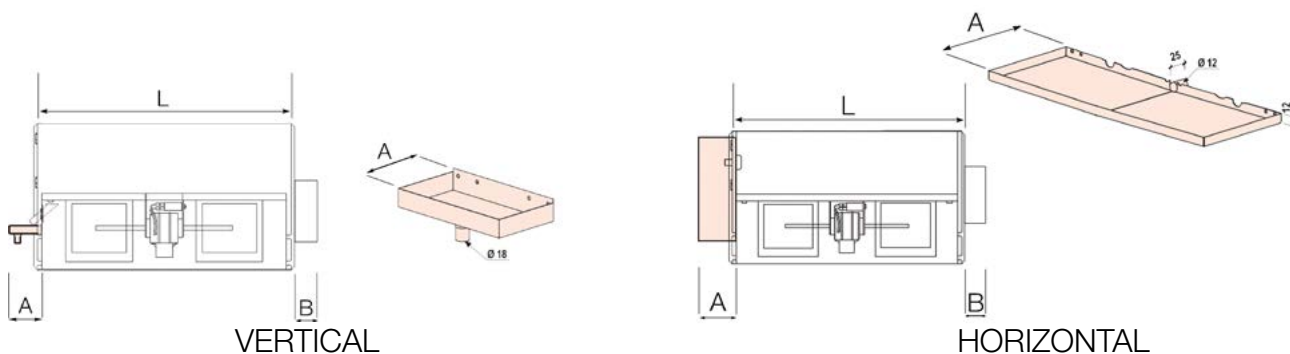

# Dimensional Information

Chassis Version	DXT Unit Model	DXT Unit Size							
		10	20	40	60	70	90	100	120
Chassis Versions 2 & 7	Length (mm) L	420	620	820	1020	1020	1220	1385	1685
	Length (mm) A	102	102	102	102	102	102	130	130
	Length (mm) B	100	100	100	100	100	100	100	100
	Length + A + B (mm)	622	822	1022	1222	1222	1422	1610	1910
	Height (mm)	460	460	460	460	565	565	585	585
	Depth (mm)	220	220	220	220	220	220	252	252
Chassis Versions 3	Length (mm) L	420	620	820	1020	1020	1220	1385	1685
	Length (mm) A	130	130	130	130	160	160	160	160
	Length (mm) B	100	100	100	100	100	100	100	100
	Length + A + B (mm)	650	850	1050	1250	1280	1480	1640	1940
	Height (mm)	460	460	460	460	565	565	585	585
	Depth (mm)	220	220	220	220	220	220	252	252
Cased Versions 0 & 9	Length (mm)	660	860	1060	1260	1260	1460	1660	1960
	Height (mm)	480	480	480	480	585	585	602	602
	Depth (mm)	225	225	225	225	225	225	257	257
Cased Versions 1 & 8	Length (mm)	660	860	1060	1260	1260	1460	1660	1960
	Height (mm)	610	610	610	610	715	715	735	735
	Depth (mm)	225	225	225	225	225	225	257	257
Cased Versions 4 & 5	Length (mm)	660	860	1060	1260	1260	1460	1660	1960
	Height (mm)	480	480	480	480	585	585	602	602
	Depth (mm)	225	225	225	225	225	225	257	257
Cased Version 6	Length (mm)	659	859	1059	1259	1259	1459	-	-
	Height (mm)	476	476	476	476	581	581	-	-
	Depth (mm)	227	227	227	227	227	227	-	-

## Acoustic Data and N.R. Guide

All sound data ascertained at 0Pa. external resistance

Sound Power Level (SWL) dB ref. 10<sup>-12</sup> W

MODEL	Spd	Factory Default Speed Settings	FREQUENCY (Hz)							Technical Sound Power dB(A)	N.R Guide
			125	250	500	1000	2000	4000	8000		
DXT 10	1		33.7	32.7	32.2	24	21.4	14.5	5.6	32	17
	2	Min	33	34.7	32.7	25.9	22.5	14.8	5.8	33	20
	3		36	37.6	37.1	30.6	25	17.6	6.9	37	23
	4	Med	37.9	41	41	35.4	29.5	21.1	8.8	41	28
	5	Max	42.1	45.1	45.5	40.8	35.6	27.7	16.1	46	33
	6		46.6	49.4	50.2	45.9	41.9	34.8	24.5	51	36
DXT 20	1		29.2	34.8	31.9	23.5	19.6	14.7	10.1	32	19
	2	Min	33.1	37.8	36	28.8	23.7	17	11.5	36	24
	3	Med	36.9	40.9	40	33.6	28.5	20.9	13.7	40	28
	4	Max	40.2	43.9	43.9	28	33.5	25.2	16.9	44	32
	5		44.7	48.3	48.7	43	39.8	32.2	25.2	49	36
	6		48.8	51.9	51.9	46.9	45.6	37.7	29.9	53	39
DXT 40	1		31.4	33.4	28.6	20.7	21.6	13.6	13	30	16
	2	Min	32.7	35.5	32.7	25	22.1	14	12.3	33	20
	3	Med	38.2	40.9	39.8	34.3	27.8	18.3	13.8	40	27
	4		41.8	44.1	43.5	38.9	32.4	23.3	16.5	44	31
	5	Max	44.5	46.5	46.2	42.2	36	28.1	19.3	47	33
	6		48.2	50.2	50.1	46.2	40.7	34	26.8	50	36
DXT 60	1		32.3	36.2	32.5	23.3	26.2	22.1	20.9	34	21
	2	Min	36.6	40	37.6	28.9	28.2	24	23.3	38	25
	3		40.5	43.8	41.9	34.3	30.3	25	23.8	42	30
	4	Med	45.1	48	47	40.6	35.2	28	25.2	47	34
	5	Max	50	52.2	51.8	46.2	40.9	33.5	29.6	52	39
	6		54.4	56.6	56.3	51.4	47.3	40.5	32.7	57	43
DXT 70	1		34.5	37.2	33.1	26.2	25.3	22.5	19.6	36	19
	2	Min	35.4	40.3	37.1	29.7	27.5	24.2	21.6	38	22
	3		39.7	43.3	41.4	34.5	31.2	26.1	22.3	42	29
	4	Med	43.1	46.9	46	39.8	36.3	28.3	24.8	46	33
	5	Max	48.5	51.3	51.3	45.6	42.4	34.5	27	52	39
	6		53.2	56.2	55.8	51.1	48.6	41.8	32.9	57	43
DXT 90	1	Min	48	50.1	50.7	45	41.3	36.2	29.8	51	38
	2		50.7	53.4	54.5	49.1	45.8	40.6	33.4	55	42
	3	Med	53.4	56.2	57	52.4	49.4	44.6	37.6	58	44
	4		55.9	59.1	59.6	55.4	52.7	48.2	42.1	61	46
	5	Max	58.8	61.9	62.4	58.4	55.9	51.7	46.4	64	51
	6		61.3	65	65	61.6	59.2	55.3	50.8	67	52
DXT 100	1		52.3	53.5	50.8	46.7	40.6	31.9	28.3	52	38
	2	Min	54.7	56.2	53.8	50.1	44.1	35.3	28.5	55	41
	3	Med	56.7	57.8	55.5	52.2	46.8	38.6	30.9	57	43
	4		59.5	60.7	58.1	55.2	50.3	42.9	38.1	60	46
	5	Max	62.1	63.5	60.7	58.3	53.8	46.9	39.9	63	49
	6		63.3	65.7	62.5	60.2	56.1	49.7	43	65	51
DXT 120	1		52.8	51.1	47.5	43.5	36.7	29.4	25.7	49	35
	2	Min	54.7	52.9	49.6	45.4	39.4	31.3	26.2	51	37
	3		60.7	60.2	57.1	53.8	49.2	41.6	33.8	59	44
	4	Med	62.4	62.2	58.9	55.9	51.6	44.7	37.8	61	46
	5	Max	66.8	66.9	63.2	61.1	57.3	51.5	45.4	66	51

Qualification of N.R. predictions: The N.R. guide figures quoted are intended to show the levels which may be expected in a typical office environments. Rooms should be carpeted, with not more than 20% glazing area or highly reflective surfaces. For accurate assessment it may be necessary to obtain confirmation from an acoustic specialist. Sound Power Levels tested in accordance with BS4856 Part 5 1979. For accurate assessment please consult our Technical Sales Department on 01484 405666.

# R407C

Performances with thermal expansion valve set at 5°C superheat

	MODEL	AIR ON °C	HUMIDITY % RH	EVAPORATING TEMPERATURE °C										
				0		2.5		5		7.5		10		
				TOTAL	SENS	TOTAL	SENS	TOTAL	SENS	TOTAL	SENS	TOTAL	SENS	
SPEED 1	10	10	70	0.26	0.26	0.19	0.19	0.12	0.12	0.07	0.07	-	-	
		12.7	70	0.33	0.33	0.26	0.26	0.19	0.19	0.13	0.13	0.07	0.07	
		15	70	0.40	0.40	0.33	0.33	0.26	0.26	0.19	0.19	0.12	0.12	
		18	60	0.48	0.48	0.41	0.41	0.33	0.33	0.27	0.27	0.20	0.20	
	21	50	0.57	0.57	0.49	0.49	0.41	0.41	0.35	0.35	0.28	0.28		
	20	10	70	0.42	0.42	0.31	0.31	0.20	0.20	0.11	0.11	-	-	
		12.7	70	0.55	0.55	0.43	0.43	0.33	0.33	0.21	0.21	0.11	0.11	
		15	70	0.66	0.66	0.53	0.53	0.42	0.42	0.31	0.31	0.20	0.20	
		18	60	0.80	0.80	0.68	0.68	0.54	0.54	0.43	0.43	0.32	0.32	
	21	50	0.95	0.95	0.82	0.82	0.70	0.70	0.57	0.57	0.46	0.46		
	40	10	70	0.57	0.57	0.42	0.42	0.27	0.27	0.14	0.14	-	-	
		12.7	70	0.76	0.76	0.58	0.58	0.44	0.44	0.28	0.28	0.15	0.15	
		15	70	0.91	0.91	0.74	0.74	0.57	0.57	0.41	0.41	0.26	0.26	
		18	60	1.10	1.10	0.93	0.93	0.76	0.76	0.59	0.59	0.44	0.44	
	21	50	1.31	1.31	1.13	1.13	0.96	0.96	0.78	0.78	0.62	0.62		
	60	10	70	0.88	0.88	0.63	0.63	0.40	0.40	0.19	0.19	-	-	
		12.7	70	1.15	1.15	0.89	0.89	0.65	0.65	0.42	0.42	0.21	0.21	
		15	70	1.40	1.40	1.12	1.12	0.87	0.87	0.63	0.63	0.40	0.40	
		18	60	1.71	1.71	1.43	1.43	1.16	1.16	0.90	0.90	0.66	0.66	
	21	50	2.03	2.03	1.75	1.75	1.47	1.47	1.21	1.21	0.95	0.95		
	70	10	70	0.98	0.98	0.71	0.71	0.46	0.46	0.22	0.22	-	-	
		12.7	70	1.28	1.28	1.00	1.00	0.74	0.74	0.48	0.48	0.24	0.24	
		15	70	1.53	1.53	1.25	1.25	0.97	0.97	0.71	0.71	0.46	0.46	
		18	60	1.85	1.85	1.56	1.56	1.28	1.28	1.00	1.00	0.74	0.74	
	21	50	2.18	2.18	1.89	1.89	1.61	1.61	1.32	1.32	1.06	1.06		
	90	10	70	1.74	1.74	1.25	1.25	0.80	0.80	0.39	0.39	-	-	
		12.7	70	2.31	2.31	1.78	1.78	1.29	1.29	0.83	0.83	0.41	0.41	
		15	70	2.81	2.81	2.25	2.25	1.72	1.72	1.24	1.24	0.79	0.79	
		18	60	3.44	3.44	2.87	2.87	2.31	2.31	1.79	1.79	1.30	1.30	
	21	50	4.10	4.10	3.52	3.52	2.96	2.96	2.41	2.41	1.90	1.90		
	100	10	70	2.02	2.02	1.44	1.44	0.92	0.92	0.44	0.44	-	-	
		12.7	70	2.68	2.68	2.06	2.06	1.49	1.49	0.95	0.95	0.48	0.48	
		15	70	3.25	3.25	2.59	2.59	1.99	1.99	1.42	1.42	0.91	0.91	
		18	60	3.99	3.99	3.33	3.33	2.68	2.68	2.08	2.08	1.50	1.50	
	21	50	4.75	4.75	4.08	4.08	3.43	3.43	2.79	2.79	2.20	2.20		
	120	10	70	2.19	2.19	1.57	1.57	1.01	1.01	0.49	0.49	-	-	
		12.7	70	2.87	2.87	2.23	2.23	1.63	1.63	1.05	1.05	0.53	0.53	
		15	70	3.47	3.47	2.80	2.80	2.16	2.16	1.55	1.55	1.00	1.00	
		18	60	4.24	4.24	3.54	3.54	2.87	2.87	2.24	2.24	1.64	1.64	
	21	50	5.04	5.04	4.32	4.32	3.65	3.65	2.99	2.99	2.37	2.37		
	SPEED 2	10	10	70	0.28	0.28	0.20	0.20	0.13	0.13	0.07	0.07	-	-
			12.7	70	0.36	0.36	0.28	0.28	0.21	0.21	0.14	0.14	0.07	0.07
			15	70	0.43	0.43	0.35	0.35	0.27	0.27	0.20	0.20	0.12	0.12
			18	60	0.51	0.51	0.43	0.43	0.35	0.35	0.29	0.29	0.20	0.20
		21	50	0.60	0.60	0.52	0.52	0.44	0.44	0.36	0.36	0.28	0.28	
		20	10	70	0.46	0.46	0.34	0.34	0.22	0.22	0.11	0.11	-	-
			12.7	70	0.60	0.60	0.47	0.47	0.36	0.36	0.23	0.23	0.11	0.11
			15	70	0.72	0.72	0.58	0.58	0.46	0.46	0.33	0.33	0.22	0.22
18			60	0.88	0.88	0.74	0.74	0.60	0.60	0.47	0.47	0.35	0.35	
21		50	1.05	1.05	0.90	0.90	0.75	0.75	0.62	0.62	0.50	0.50		
40		10	70	0.65	0.65	0.47	0.47	0.30	0.30	0.15	0.15	-	-	
		12.7	70	0.86	0.86	0.66	0.66	0.49	0.49	0.31	0.31	0.16	0.16	
		15	70	1.03	1.03	0.84	0.84	0.64	0.64	0.46	0.46	0.29	0.29	
		18	60	1.26	1.26	1.05	1.05	0.86	0.86	0.67	0.67	0.48	0.48	
21		50	1.50	1.50	1.29	1.29	1.08	1.08	0.89	0.89	0.71	0.71		
60		10	70	0.99	0.99	0.71	0.71	0.45	0.45	0.21	0.21	-	-	
		12.7	70	1.30	1.30	1.00	1.00	0.72	0.72	0.46	0.46	0.23	0.23	
		15	70	1.58	1.58	1.27	1.27	0.97	0.97	0.70	0.70	0.44	0.44	
		18	60	1.94	1.94	1.62	1.62	1.31	1.31	1.01	1.01	0.74	0.74	
21		50	2.32	2.32	1.99	1.99	1.67	1.67	1.36	1.36	1.07	1.07		
70		10	70	1.11	1.11	0.80	0.80	0.51	0.51	0.24	0.24	-	-	
		12.7	70	1.44	1.44	1.12	1.12	0.83	0.83	0.53	0.53	0.26	0.26	
		15	70	1.74	1.74	1.41	1.41	1.09	1.09	0.79	0.79	0.51	0.51	
		18	60	2.10	2.10	1.77	1.77	1.45	1.45	1.13	1.13	0.83	0.83	
21		50	2.47	2.47	2.15	2.15	1.82	1.82	1.50	1.50	1.19	1.19		
90		10	70	1.98	1.98	1.40	1.40	0.89	0.89	0.42	0.42	-	-	
		12.7	70	2.64	2.64	2.02	2.02	1.45	1.45	0.93	0.93	0.45	0.45	
		15	70	3.22	3.22	2.57	2.57	1.95	1.95	1.38	1.38	0.88	0.88	
		18	60	3.98	3.98	3.31	3.31	2.65	2.65	2.04	2.04	1.47	1.47	
21		50	4.76	4.76	4.07	4.07	3.41	3.41	2.76	2.76	2.16	2.16		
100		10	70	2.18	2.18	1.55	1.55	0.98	0.98	0.47	0.47	-	-	
		12.7	70	2.91	2.91	2.23	2.23	1.60	1.60	1.02	1.02	0.50	0.50	
		15	70	3.53	3.53	2.81	2.81	2.15	2.15	1.53	1.53	0.97	0.97	
		18	60	4.35	4.35	3.62	3.62	2.91	2.91	2.24	2.24	1.62	1.62	
21		50	5.17	5.17	4.45	4.45	3.73	3.73	3.03	3.03	2.38	2.38		
120		10	70	2.42	2.42	1.74	1.74	1.11	1.11	0.53	0.53	-	-	
		12.7	70	3.21	3.21	2.47	2.47	1.79	1.79	1.15	1.15	0.58	0.58	
		15	70	3.89	3.89	3.13	3.13	2.39	2.39	1.72	1.72	1.10	1.10	
		18	60	4.77	4.77	3.96	3.96	3.20	3.20	2.50	2.50	1.81	1.81	
21		50	5.68	5.68	4.85	4.85	4.10	4.10	3.34	3.34	2.64	2.64		

# R407C

Performances with thermal expansion valve set at 5°C superheat

	MODEL	AIR ON °C	HUMIDITY % RH	EVAPORATING TEMPERATURE °C										
				0		2.5		5		7.5		10		
				TOTAL	SENS	TOTAL	SENS	TOTAL	SENS	TOTAL	SENS	TOTAL	SENS	
SPEED 3	10	10	70	0.30	0.30	0.22	0.22	0.14	0.14	0.08	0.08	-	-	
		12.7	70	0.39	0.39	0.31	0.31	0.23	0.23	0.15	0.15	0.08	0.08	
		15	70	0.47	0.47	0.38	0.38	0.30	0.30	0.22	0.22	0.14	0.14	
		18	60	0.57	0.57	0.48	0.48	0.39	0.39	0.31	0.31	0.23	0.23	
	20	21	50	0.68	0.68	0.58	0.58	0.49	0.49	0.40	0.40	0.33	0.33	
		10	70	0.50	0.50	0.37	0.37	0.24	0.24	0.11	0.11	-	-	
		12.7	70	0.66	0.66	0.52	0.52	0.39	0.39	0.25	0.25	0.12	0.12	
		15	70	0.80	0.80	0.65	0.65	0.49	0.49	0.37	0.37	0.24	0.24	
	40	18	60	0.99	0.99	0.82	0.82	0.66	0.66	0.52	0.52	0.38	0.38	
		21	50	1.18	1.18	1.00	1.00	0.84	0.84	0.69	0.69	0.55	0.55	
		10	70	0.80	0.80	0.57	0.57	0.36	0.36	0.17	0.17	-	-	
		12.7	70	1.06	1.06	0.82	0.82	0.58	0.58	0.37	0.37	0.18	0.18	
	60	15	70	1.29	1.29	1.03	1.03	0.79	0.79	0.56	0.56	0.35	0.35	
		18	60	1.58	1.58	1.32	1.32	1.06	1.06	0.82	0.82	0.59	0.59	
		21	50	1.87	1.87	1.62	1.62	1.36	1.36	1.11	1.11	0.87	0.87	
		10	70	1.10	1.10	0.77	0.77	0.49	0.49	0.23	0.23	-	-	
	70	12.7	70	1.47	1.47	1.12	1.12	0.80	0.80	0.51	0.51	0.25	0.25	
		15	70	1.79	1.79	1.43	1.43	1.08	1.08	0.76	0.76	0.49	0.49	
		18	60	2.21	2.21	1.84	1.84	1.47	1.47	1.14	1.14	0.81	0.81	
		21	50	2.62	2.62	2.26	2.26	1.89	1.89	1.53	1.53	1.20	1.20	
	90	10	70	1.27	1.27	0.91	0.91	0.58	0.58	0.27	0.27	-	-	
		12.7	70	1.66	1.66	1.29	1.29	0.95	0.95	0.60	0.60	0.30	0.30	
		15	70	2.00	2.00	1.62	1.62	1.25	1.25	0.90	0.90	0.57	0.57	
		18	60	2.43	2.43	2.05	2.05	1.66	1.66	1.30	1.30	0.95	0.95	
	100	21	50	2.86	2.86	2.48	2.48	2.11	2.11	1.73	1.73	1.37	1.37	
		10	70	2.13	2.13	1.50	1.50	0.95	0.95	0.44	0.44	-	-	
		12.7	70	2.85	2.85	2.17	2.17	1.55	1.55	0.98	0.98	0.48	0.48	
		15	70	3.49	3.49	2.77	2.77	2.10	2.10	1.48	1.48	0.94	0.94	
	120	18	60	4.32	4.32	3.58	3.58	2.85	2.85	2.19	2.19	1.56	1.56	
		21	50	5.14	5.14	4.42	4.42	3.68	3.68	2.98	2.98	2.23	2.23	
		10	70	2.30	2.30	1.63	1.63	1.02	1.02	0.49	0.49	-	-	
		12.7	70	3.07	3.07	2.35	2.35	1.68	1.68	1.06	1.06	0.52	0.52	
	10	15	70	3.75	3.75	2.98	2.98	2.27	2.27	1.61	1.61	1.01	1.01	
		18	60	4.61	4.61	3.84	3.84	3.08	3.08	2.37	2.37	1.70	1.70	
		21	50	5.46	5.46	4.73	4.73	3.96	3.96	3.21	3.21	2.51	2.51	
		10	70	3.01	3.01	2.12	2.12	1.33	1.33	0.63	0.63	-	-	
	20	12.7	70	4.04	4.04	3.07	3.07	2.20	2.20	1.38	1.38	0.68	0.68	
		15	70	4.95	4.95	3.94	3.94	2.97	2.97	2.10	2.10	1.32	1.32	
		18	60	6.12	6.12	5.05	5.05	4.05	4.05	3.10	3.10	2.22	2.22	
		21	50	7.25	7.25	6.23	6.23	5.23	5.23	4.23	4.23	3.29	3.29	
	SPEED 4	10	10	70	0.32	0.32	0.24	0.24	0.16	0.16	0.08	0.08	-	-
			12.7	70	0.42	0.42	0.34	0.34	0.25	0.25	0.16	0.16	0.08	0.08
			15	70	0.51	0.51	0.41	0.41	0.32	0.32	0.24	0.24	0.16	0.16
			18	60	0.63	0.63	0.53	0.53	0.43	0.43	0.34	0.34	0.25	0.25
		20	21	50	0.76	0.76	0.63	0.63	0.55	0.55	0.45	0.45	0.36	0.36
			10	70	0.56	0.56	0.41	0.41	0.26	0.26	0.13	0.13	-	-
			12.7	70	0.74	0.74	0.58	0.58	0.44	0.44	0.27	0.27	0.14	0.14
			15	70	0.90	0.90	0.73	0.73	0.55	0.55	0.40	0.40	0.26	0.26
40		18	60	1.11	1.11	0.92	0.92	0.74	0.74	0.58	0.58	0.42	0.42	
		21	50	1.34	1.34	1.14	1.14	0.95	0.95	0.77	0.77	0.61	0.61	
		10	70	0.90	0.90	0.63	0.63	0.39	0.39	0.18	0.18	-	-	
		12.7	70	1.19	1.19	0.91	0.91	0.65	0.65	0.41	0.41	0.19	0.19	
60		15	70	1.45	1.45	1.16	1.16	0.88	0.88	0.62	0.62	0.39	0.39	
		18	60	1.77	1.77	1.49	1.49	1.19	1.19	0.92	0.92	0.66	0.66	
		21	50	2.09	2.09	1.81	1.81	1.53	1.53	1.25	1.25	0.98	0.98	
		10	70	1.22	1.22	0.86	0.86	0.54	0.54	0.25	0.25	-	-	
70		12.7	70	1.65	1.65	1.25	1.25	0.89	0.89	0.56	0.56	0.27	0.27	
		15	70	2.02	2.02	1.60	1.60	1.20	1.20	0.84	0.84	0.53	0.53	
		18	60	2.49	2.49	2.07	2.07	1.65	1.65	1.26	1.26	0.90	0.90	
		21	50	2.93	2.93	2.54	2.54	2.13	2.13	1.72	1.72	1.34	1.34	
90		10	70	1.45	1.45	1.03	1.03	0.65	0.65	0.30	0.30	-	-	
		12.7	70	1.91	1.91	1.48	1.48	1.06	1.06	0.68	0.68	0.33	0.33	
		15	70	2.31	2.31	1.87	1.87	1.43	1.43	1.02	1.02	0.65	0.65	
		18	60	2.79	2.79	2.37	2.37	1.92	1.92	1.49	1.49	1.08	1.08	
100		21	50	3.27	3.27	2.85	2.85	2.43	2.43	2.00	2.00	1.58	1.58	
		10	70	2.29	2.29	1.61	1.61	1.00	1.00	0.47	0.47	-	-	
		12.7	70	3.10	3.10	2.34	2.34	1.66	1.66	1.04	1.04	0.51	0.51	
		15	70	3.80	3.80	3.01	3.01	2.26	2.26	1.59	1.59	0.99	0.99	
120		18	60	4.72	4.72	3.90	3.90	3.11	3.11	2.37	2.37	1.68	1.68	
		21	50	5.58	5.58	4.83	4.83	4.02	4.02	3.24	3.24	2.51	2.51	
		10	70	2.59	2.59	1.81	1.81	1.13	1.13	0.52	0.52	-	-	
		12.7	70	3.48	3.48	2.64	2.64	1.87	1.87	1.17	1.17	0.57	0.57	
10		15	70	4.27	4.27	3.38	3.38	2.55	2.55	1.78	1.78	1.12	1.12	
		18	60	5.24	5.24	4.38	4.38	3.50	3.50	2.67	2.67	1.89	1.89	
		21	50	6.18	6.18	5.35	5.35	4.52	4.52	3.64	3.64	2.83	2.83	
		10	70	3.14	3.14	2.20	2.20	1.37	1.37	0.65	0.65	-	-	
20		12.7	70	4.23	4.23	3.21	3.21	2.28	2.28	1.43	1.43	0.69	0.69	
		15	70	5.18	5.18	4.12	4.12	3.10	3.10	2.17	2.17	1.37	1.37	
		18	60	6.42	6.42	5.30	5.30	4.24	4.24	3.24	3.24	2.31	2.31	
		21	50	7.58	7.58	6.52	6.52	5.48	5.48	4.42	4.42	3.44	3.44	

# R407C

Performances with thermal expansion valve set at 5°C superheat

	MODEL	AIR ON °C	HUMIDITY % RH	EVAPORATING TEMPERATURE °C										
				0		2.5		5		7.5		10		
				TOTAL	SENS	TOTAL	SENS	TOTAL	SENS	TOTAL	SENS	TOTAL	SENS	
SPEED 5	10	10	70	0.36	0.36	0.27	0.27	0.17	0.17	0.08	0.08	-	-	
		12.7	70	0.47	0.47	0.36	0.36	0.27	0.27	0.18	0.18	0.09	0.09	
		15	70	0.57	0.57	0.46	0.46	0.35	0.35	0.27	0.27	0.17	0.17	
		18	60	0.71	0.71	0.59	0.59	0.48	0.48	0.37	0.37	0.27	0.27	
		21	50	0.85	0.85	0.73	0.73	0.61	0.61	0.50	0.50	0.39	0.39	
	20	10	70	0.62	0.62	0.44	0.44	0.29	0.29	0.14	0.14	-	-	
		12.7	70	0.83	0.83	0.64	0.64	0.49	0.49	0.30	0.30	0.15	0.15	
		15	70	1.02	1.02	0.81	0.81	0.62	0.62	0.44	0.44	0.29	0.29	
		18	60	1.27	1.27	1.05	1.05	0.83	0.83	0.65	0.65	0.47	0.47	
		21	50	1.54	1.54	1.31	1.31	1.09	1.09	0.88	0.88	0.68	0.68	
	40	10	70	0.99	0.99	0.69	0.69	0.42	0.42	0.19	0.19	-	-	
		12.7	70	1.32	1.32	1.00	1.00	0.71	0.71	0.44	0.44	0.21	0.21	
		15	70	1.61	1.61	1.28	1.28	0.97	0.97	0.68	0.68	0.42	0.42	
		18	60	1.96	1.96	1.65	1.65	1.33	1.33	1.02	1.02	0.72	0.72	
		21	50	2.30	2.30	2.00	2.00	1.70	1.70	1.39	1.39	1.08	1.08	
	60	10	70	1.38	1.38	0.96	0.96	0.59	0.59	0.27	0.27	-	-	
		12.7	70	1.88	1.88	1.42	1.42	0.99	0.99	0.62	0.62	0.29	0.29	
		15	70	2.31	2.31	1.83	1.83	1.36	1.36	0.94	0.94	0.59	0.59	
		18	60	2.82	2.82	2.37	2.37	1.88	1.88	1.43	1.43	1.01	1.01	
		21	50	3.34	3.34	2.88	2.88	2.44	2.44	1.97	1.97	1.51	1.51	
	70	10	70	1.70	1.70	1.20	1.20	0.75	0.75	0.34	0.34	-	-	
		12.7	70	2.27	2.27	1.74	1.74	1.24	1.24	0.78	0.78	0.37	0.37	
		15	70	2.72	2.72	2.21	2.21	1.68	1.68	1.19	1.19	0.74	0.74	
		18	60	3.29	3.29	2.78	2.78	2.27	2.27	1.75	1.75	1.26	1.26	
		21	50	3.86	3.86	3.36	3.36	2.86	2.86	2.37	2.37	1.86	1.86	
	90	10	70	2.45	2.45	1.71	1.71	1.05	1.05	0.49	0.49	-	-	
		12.7	70	3.33	3.33	2.50	2.50	1.76	1.76	1.10	1.10	0.53	0.53	
		15	70	4.10	4.10	3.24	3.24	2.41	2.41	1.69	1.69	1.04	1.04	
		18	60	5.06	5.06	4.21	4.21	3.33	3.33	2.54	2.54	1.78	1.78	
		21	50	5.99	5.99	5.18	5.18	4.34	4.34	3.49	3.49	2.69	2.69	
	100	10	70	2.79	2.79	1.94	1.94	1.20	1.20	0.55	0.55	-	-	
		12.7	70	3.77	3.77	2.85	2.85	2.01	2.01	1.24	1.24	0.60	0.60	
		15	70	4.64	4.64	3.65	3.65	2.75	2.75	1.91	1.91	1.19	1.19	
		18	60	5.65	5.65	4.76	4.76	3.78	3.78	2.88	2.88	2.03	2.03	
		21	50	6.68	6.68	5.78	5.78	4.90	4.90	3.95	3.95	3.06	3.06	
	120	10	70	3.85	3.85	2.64	2.64	1.61	1.61	0.74	0.74	-	-	
		12.7	70	5.26	5.26	3.93	3.93	2.74	2.74	1.68	1.68	0.80	0.80	
		15	70	6.49	6.49	5.12	5.12	3.78	3.78	2.60	2.60	1.59	1.59	
		18	60	7.90	7.90	6.61	6.61	5.28	5.28	3.98	3.98	2.78	2.78	
		21	50	9.36	9.36	8.04	8.04	6.83	6.83	5.52	5.52	4.24	4.24	
	SPEED 6	10	10	70	0.36	0.39	0.29	0.29	0.19	0.19	0.09	0.09	-	-
			12.7	70	0.52	0.52	0.40	0.40	0.30	0.30	0.20	0.20	0.10	0.10
			15	70	0.64	0.64	0.51	0.51	0.39	0.39	0.29	0.29	0.19	0.19
			18	60	0.80	0.80	0.66	0.66	0.53	0.53	0.41	0.41	0.30	0.30
			21	50	0.97	0.97	0.81	0.81	0.68	0.68	0.55	0.55	0.43	0.43
		20	10	70	0.69	0.69	0.49	0.49	0.31	0.31	0.15	0.15	-	-
			12.7	70	0.93	0.93	0.70	0.70	0.53	0.53	0.33	0.33	0.16	0.16
			15	70	1.15	1.15	0.90	0.90	0.68	0.68	0.48	0.48	0.31	0.31
18			60	1.44	1.44	1.18	1.18	0.93	0.93	0.71	0.71	0.52	0.52	
		21	50	1.75	1.75	1.48	1.48	1.22	1.22	0.98	0.98	0.76	0.76	
40		10	70	1.11	1.11	0.76	0.76	0.47	0.47	0.21	0.21	-	-	
		12.7	70	1.50	1.50	1.13	1.13	0.79	0.79	0.49	0.49	0.23	0.23	
		15	70	1.81	1.81	1.46	1.46	1.09	1.09	0.75	0.75	0.46	0.46	
		18	60	2.20	2.20	1.86	1.86	1.51	1.51	1.15	1.15	0.80	0.80	
		21	50	2.60	2.60	2.25	2.25	1.91	1.91	1.57	1.57	1.22	1.22	
60		10	70	1.57	1.57	1.07	1.07	0.65	0.65	0.29	0.29	-	-	
		12.7	70	2.15	2.15	1.60	1.60	1.11	1.11	0.68	0.68	0.32	0.32	
		15	70	2.63	2.63	2.09	2.09	1.55	1.55	1.06	1.06	0.64	0.64	
		18	60	3.20	3.20	2.69	2.69	2.16	2.16	1.63	1.63	1.12	1.12	
		21	50	3.79	3.79	3.27	3.27	2.77	2.77	2.26	2.26	1.72	1.72	
70		10	70	2.01	2.01	1.40	1.40	0.86	0.86	0.39	0.39	-	-	
		12.7	70	2.66	2.66	2.05	2.05	1.45	1.45	0.90	0.90	0.42	0.42	
		15	70	3.18	3.18	2.60	2.60	1.98	1.98	1.38	1.38	0.85	0.85	
		18	60	3.84	3.84	3.25	3.25	2.66	2.66	2.07	2.07	1.47	1.47	
		21	50	4.52	4.52	3.93	3.93	3.34	3.34	2.77	2.77	2.20	2.20	
90		10	70	2.69	2.69	1.85	1.85	1.13	1.13	0.52	0.52	-	-	
		12.7	70	3.66	3.66	2.75	2.75	1.91	1.91	1.18	1.18	0.57	0.57	
		15	70	4.54	4.54	3.56	3.56	2.65	2.65	1.82	1.82	1.12	1.12	
		18	60	5.55	5.55	4.66	4.66	3.68	3.68	2.78	2.78	1.94	1.94	
		21	50	6.58	6.58	5.68	5.68	4.80	4.80	3.84	3.84	2.96	2.96	
100		10	70	3.01	3.01	2.06	2.06	1.26	1.26	0.58	0.58	-	-	
		12.7	70	4.10	4.10	3.08	3.08	2.15	2.15	1.32	1.32	0.63	0.63	
		15	70	5.03	5.03	3.97	3.97	2.96	2.96	2.05	2.05	1.25	1.25	
		18	60	6.11	6.11	5.14	5.14	4.12	4.12	3.12	3.12	2.18	2.18	
		21	50	7.23	7.23	6.25	6.25	5.28	5.28	4.30	4.30	3.31	3.31	

# Electrical Data

ELECTRICAL DATA										
MODEL	Spd	A'flow (l/s)	Input (watts)		FLC (Amps)		S.C. (Amps)		Specific Fan Power	
			AC	EC/DC	AC	EC/DC	AC	EC/DC	AC	EC/DC
DXT 10	1	33	19	6	0.11	0.09	0.17	0.14	0.58	0.18
	2	36	22	6	0.13	0.10	0.20	0.15	0.61	0.17
	3	42	25	8	0.15	0.12	0.23	0.18	0.59	0.19
	4	50	28	10	0.17	0.15	0.25	0.23	0.56	0.20
	5	60	30	11	0.18	0.17	0.27	0.25	0.50	0.18
	6	73	32	12	0.19	0.18	0.29	0.27	0.44	0.16
DXT 20	1	49	21	10	0.13	0.11	0.19	0.16	0.43	0.21
	2	55	24	11	0.14	0.12	0.22	0.17	0.43	0.20
	3	64	27	13	0.16	0.14	0.24	0.20	0.42	0.20
	4	76	30	15	0.18	0.16	0.27	0.24	0.39	0.20
	5	92	35	18	0.21	0.19	0.32	0.28	0.38	0.20
	6	108	38	20	0.23	0.21	0.34	0.32	0.35	0.18
DXT 40	1	59	28	12	0.17	0.22	0.25	0.32	0.47	0.20
	2	69	31	13	0.19	0.23	0.28	0.35	0.45	0.19
	3	91	39	15	0.23	0.27	0.35	0.41	0.43	0.17
	4	105	45	16	0.27	0.29	0.41	0.43	0.43	0.15
	5	119	50	18	0.30	0.32	0.45	0.49	0.42	0.15
	6	140	54	21	0.32	0.38	0.49	0.57	0.39	0.15
DXT 60	1	98	43	15	0.26	0.41	0.39	0.61	0.44	0.15
	2	113	51	18	0.31	0.49	0.46	0.73	0.45	0.16
	3	132	60	20	0.36	0.54	0.54	0.81	0.45	0.15
	4	153	72	28	0.43	0.76	0.65	1.13	0.47	0.18
	5	181	80	34	0.48	0.92	0.72	1.38	0.44	0.19
	6	215	90	42	0.54	1.13	0.81	1.70	0.42	0.20
DXT 70	1	94	39	14	0.23	0.25	0.35	0.38	0.42	0.15
	2	109	46	17	0.28	0.31	0.41	0.46	0.42	0.16
	3	128	52	19	0.31	0.34	0.47	0.51	0.41	0.15
	4	153	64	28	0.38	0.50	0.58	0.76	0.42	0.18
	5	187	70	35	0.42	0.63	0.63	0.95	0.37	0.19
	6	229	83	44	0.50	0.79	0.75	1.19	0.36	0.19
DXT 90	1	203	138	45	0.83	0.48	1.24	0.72	0.71	0.22
	2	243	152	61	0.91	0.65	1.37	0.97	0.63	0.25
	3	268	162	78	0.97	0.83	1.46	1.24	0.61	0.29
	4	298	171	90	1.03	0.95	1.54	1.43	0.57	0.30
	5	328	180	103	1.08	1.09	1.62	1.64	0.55	0.31
	6	372	203	113	1.22	1.20	1.83	1.80	0.55	0.30
DXT 100	1	231	143	52	0.86	0.55	1.29	0.83	0.62	0.22
	2	258	165	64	0.99	0.68	1.49	1.02	0.64	0.25
	3	289	189	79	1.13	0.84	1.70	1.26	0.65	0.27
	4	323	203	102	1.22	1.08	1.83	1.62	0.63	0.32
	5	359	213	116	1.28	1.23	1.92	1.84	0.59	0.32
	6	398	218	135	1.31	1.43	1.96	2.15	0.55	0.34
DXT 120	1	242	162	61	0.97	0.65	1.46	0.97	0.67	0.25
	2	279	178	79	1.07	0.84	1.60	1.26	0.64	0.28
	3	378	214	135	1.28	1.43	1.93	2.15	0.57	0.36
	4	421	234	156	1.40	1.65	2.11	2.48	0.56	0.37
	5	530	273	201	1.64	2.13	2.46	3.20	0.52	0.38

**T: 01484 405 666**  
**E: sales@marstair.com**

TEV has earned management system accreditations – BSI 14001: 2015 Environmental Management and BSI 9001: 2015 Quality Management.



**Part No: 06617710-08**